

Application manual



Supports Firmware Version Bundle:
DH1-V0003-JCI

Disclaimer of warranties and limitation of liability

The information, recommendations, descriptions, and safety notations in this document are based on Johnson Controls' experience and judgment and may not cover all contingencies. If further information is required, a Johnson Controls sales office should be consulted. Sale of the product shown in this literature is subject to the terms and conditions outlined in appropriate Johnson Controls selling policies or other contractual agreement between Johnson Controls and the purchaser.

THERE ARE NO UNDERSTANDINGS, AGREEMENTS, WARRANTIES, EXPRESSED OR IMPLIED, INCLUDING WARRANTIES OF FITNESS FOR A PARTICULAR PURPOSE OR MERCHANTABILITY, OTHER THAN THOSE SPECIFICALLY SET OUT IN ANY EXISTING CONTRACT BETWEEN THE PARTIES. ANY SUCH CONTRACT STATES THE ENTIRE OBLIGATION OF JOHNSON CONTROLS. THE CONTENTS OF THIS DOCUMENT SHALL NOT BECOME PART OF OR MODIFY ANY CONTRACT BETWEEN THE PARTIES.

In no event will Johnson Controls be responsible to the purchaser or user in contract, in tort (including negligence), strict liability, or otherwise for any special, indirect, incidental, or consequential damage or loss whatsoever, including but not limited to damage or loss of use of equipment, plant or power system, cost of capital, loss of power, additional expenses in the use of existing power facilities, or claims against the purchaser or user by its customers resulting from the use of the information, recommendations, and descriptions contained herein. The information contained in this manual is subject to change without notice.

Cover Photo: Johnson Controls Variable Speed Drive Series III

Support services

Support services

The goal of Johnson Controls is to ensure your greatest possible satisfaction with the operation of our products. We are dedicated to providing fast, friendly, and accurate assistance. That is why we offer you so many ways to get the support you need. Whether it is by phone, fax, or email, you can access Johnson Controls' support information 24 hours a day, seven days a week.

Our wide range of services is listed below.

You should contact your local distributor for product pricing, availability, ordering, expediting, and repairs.

Website

Use the Johnson Controls website to find product information.

Website address

www.johnsoncontrols.com -> HVAC Controls -> Variable Speed Drives

Johnson Controls product sales operation/ technical support

Call Local Service Center Representative.

If Representative is unknown, call 1-800-482-2778 and ask for a local service rep for programming support.

Table of contents

SAFETY

Before commencing the installation	xv
Definitions and symbols	xvi
Hazardous high voltage	xvi
Warnings and cautions	xvi
Important safety information	xvii

CHAPTER 1—VARIABLE SPEED DRIVES SERIES III OVERVIEW

How to use this manual	1
Receiving and inspection	1
Real time clock battery activation	1
Rating label	2
Carton rating label	2
Catalog number system	3
Power ratings and product selection	4

CHAPTER 2—KEYPAD OVERVIEW

Overview	8
Keypad buttons	9
LED lights	11
LCD display	11

CHAPTER 3—MENU OVERVIEW

Main menu page	14
Menu navigation	14
Menu structure	15
M — Monitor	16
F — Fault	17
Pop-up fault	18
Fault history	19
Fault Log	20
P — Parameter	20
Value edit	25
T—Favorite	26

CHAPTER 4—STARTUP

Startup wizard page	27
Startup wizard	27
PID and Advanced Application Mini-Wizard	28

CHAPTER 5—BASIC APPLICATION

I/O controls	29
Force open/force close selection	30
DIGIN selection	30
Option board digIN selection	30
Basic Application Control I/O configuration	31

Table of contents, continued

CHAPTER 5—BASIC APPLICATION, continued

Control I/O configuration33
Basic application—parameters list33
Monitor33
Parameters36
Inputs.37
Outputs40
Drive Control43
Motor Control44
Protections44
Communication48
RS485 Bus.49
EtherNet Bus.50
System.51

CHAPTER 6 — PID APPLICATION

Introduction54
I/O controls54
Force open/force close selection55
DIGIN selection55
Option board DigIN selection55
Timer channel selection.55
Control I/O configuration56
PID application—parameters list57
Parameters62
Inputs.62
Outputs66
Drive Control69
Motor Control71
Protections71
PID Controller 174
Setpoint75
Feedback76
Feedforward77
PID Controller 2.78
Setpoint79
Feedback80
Feedforward81
Bypass.82
Real Time Clock83
Communication84
RS485 Bus.86
EtherNet Bus.87
System.88

Table of contents, continued

CHAPTER 7—ADVANCED APPLICATION PARAMETER

I/O Controls92
Force open/force close selection93
DIGIN selection93
Option board digIN selection.93
Timer channel selection.93
Control I/O configuration94
Advanced application—Parameters List96
Monitor96
Parameters99
Outputs	104
Drive Control	108
Motor Control	109
Protections	110
PID Controller 1	113
Setpoint	114
Feedback	116
Feedforward	116
PID Controller 2	117
Setpoint	118
Feedback	119
Feedforward	120
Bypass.	121
Real Time Clock	121
Communication	123
RS485 Bus.	124
EtherNet Bus.	125
System.	126

APPENDIX A – DESCRIPTION OF PARAMETERS

Application level	130
-----------------------------	-----

APPENDIX B – FAULT LOG

Fault codes and descriptions	210
--	-----

APPENDIX C – RECOMMENDED SECURE HARDENING GUIDELINES

Introduction	213
Secure configuration guidelines	213

List of figures

Figure 1. RTC battery connection	1
Figure 2. VS3 rating label	2
Figure 3. VS3 carton rating label	2
Figure 4. Johnson Controls Series III VSD—catalog numbering system	3
Figure 5. Keypad and display	8
Figure 6. General view of LCD	11
Figure 7. Welcome page	11
Figure 8. Upgrade page	12
Figure 9. Auto backup page	12
Figure 10. Main menu.	12
Figure 11. Parent node page	13
Figure 12. Parameter page	13
Figure 13. Parameter page from favorite menu	13
Figure 14. Fault page	13
Figure 15. Main menu page	14
Figure 16. Main menu navigation	14
Figure 17. M—Monitor	16
Figure 18. Active faults	17
Figure 19. Pop-up active faults	18
Figure 20. Fault history	19
Figure 21. Parameter setting.	20
Figure 22. Parameter sets	21
Figure 23. Down from keypad	22
Figure 24. Parameters comparison.	23
Figure 25. Password.	24
Figure 26. Edit parameter value	25
Figure 27. Parameter locked	26
Figure 28. Acceleration and deceleration time	130
Figure 29. Motor parameters from ratings plate	131
Figure 30. With and without reference scaling.	134
Figure 31. Start forward/start reverse.	134
Figure 32. Start, stop and reverse	135
Figure 33. Start pulse/stop pulse	136
Figure 34. Start forward/start reverse	137
Figure 35. Start pulse/stop pulse	138
Figure 36. Activation of fixed frequencies	142
Figure 37. AI1 2wire-current	146
Figure 38. AI1 3wire-current.	146
Figure 39. AI1 4wire-current.	147

List of figures, continued

Figure 40. AI1 reference potentiometer 10V 147

Figure 41. Analog input AI scaling. 147

Figure 42. AI1 signal filtering 148

Figure 43. AI1 No signal inversion 148

Figure 44. AI1 Signal Inversion 148

Figure 45. Example of joystick hysteresis 149

Figure 46. Example of sleep limit function. 149

Figure 47. AI2 2wire-current 150

Figure 48. AI2 3wire-current. 150

Figure 49. AI2 4wire-current. 150

Figure 50. AI2 differential voltage. 150

Figure 51. AI2 pot ref. 151

Figure 52. Supervision function 158

Figure 53. Analog output filtering 161

Figure 54. Analog output scaling 162

Figure 55. Analog output invert 162

Figure 56. Acceleration/Deceleration (S-shaped) 164

Figure 57. DC-Braking time when stop mode = coasting. 166

Figure 58. DC-Braking time when stop mode = ramp 166

Figure 59. Example of skip frequency area setting 168

Figure 60. Linear and squared change of motor voltage 169

Figure 61. Programmable V/Hz curve 170

Figure 62. Motor thermal current it curve 172

Figure 63. Motor temperature calculation 173

Figure 64. Stall characteristics settings 174

Figure 65. Stall time count 174

Figure 66. Setting of minimum load. 175

Figure 67. Underload time counter function. 175

Figure 68. Auto restart fail (try number >2.). 179

Figure 69. Setting up PID application 183

Figure 70. Setting up PID application 188

List of tables

Table 1. Common abbreviations	1
Table 2. Open Type /IP20	4
Table 3. Type 1/IP21	4
Table 4. Type 12/IP54	4
Table 5. Open Type /IP20	5
Table 6. Type 1/IP21	5
Table 7. Type 12/IP54	6
Table 8. Type 1/IP21	6
Table 9. Type 12/IP54	7
Table 10. Keypad buttons	9
Table 11. LED state indicators	11
Table 12. Soft keys	12
Table 13. Keypad menus	15
Table 14. Startup wizard instructions	27
Table 14. Startup wizard instructions continued	28
Table 15. PID Mini-Wizard values	28
Table 16. I/O connection	31
Table 17. Drive communication ports	32
Table 18. Basic—M1	33
Table 19. IO Status—M2	33
Table 20. Optional Boards — M3	34
Table 21. Energy Savings — M4	34
Table 22. FB Monitor Menu — M5	34
Table 22. FB Monitor Menu — M5 continued	35
Table 23. User Defined Output — M8	35
Table 24. MWH Monitor — M9	35
Table 25. Multi-Monitoring — M10	36
Table 26. Basic Parameters — P1	36
Table 27. Basic Setting — P2.1	37
Table 28. Digital Input — P2.2	37
Table 28. Digital Input — P2.2, continued	38
Table 29. Preset Speed — P2.3	39
Table 30. AI1 Settings — P2.4	39
Table 31. AI2 Settings — P2.5	39
Table 32. Digital Output — P3.1	40
Table 32. Digital Output — P3.1 continued	41
Table 33. Supervisions — P3.2	41
Table 33. Supervisions — P3.2 continued	42
Table 34. Analog Output 1 — P3.3	42
Table 35. Analog Output 2 — P3.4	42
Table 36. Basic Setting — P4.1	43
Table 37. Brake — P4.2	43
Table 38. Skip Frequency — P4.3	43

List of tables, continued

Table 39. Analog Output 2 — P3.4	.44
Table 40. Basic Setting — P5.1	.44
Table 41. Motor — P6.1	.44
Table 42. Drive — P6.2	.46
Table 43. Communication — P6.3	.46
Table 44. Auto Restart — P6.4	.47
Table 45. Fire Mode — P9	.47
Table 46. Basic Setting — P10.1	.47
Table 47. FB Process Data Input Sel — P12.1	.48
Table 48. FB Process Data Output Sel — P12.2	.48
Table 49. Basic Setting — P12.3.1	.49
Table 50. Modbus RTU — P12.3.2	.49
Table 51. BACnet MS/TP — P12.3.3	.50
Table 52. SA Bus — P12.3.4	.50
Table 53. Basic Setting — P12.4.1	.50
Table 54. Modbus TCP — P12.4.2	.50
Table 55. BACnet IP — P12.4.3	.51
Table 56. Basic Setting — P13.1	.51
Table 57. Version Info — P13.2	.53
Table 58. Application Info — P13.3	.53
Table 59. User Info — P13.4	.53
Table 60. Operate Mode — O	.53
Table 61. PID application default I/O connection	.56
Table 62. Drive communication ports	.57
Table 63. Basic - M1	.58
Table 64. IO Status — M2	.58
Table 65. Optional Boards — M3	.58
Table 66. Energy Savings — M4	.58
Table 67. FB Monitor Menu — M5	.59
Table 68. PID Monitor — M6	.60
Table 69. Timer/Interval Control — M7	.61
Table 70. User Defined Output — M8	.61
Table 71. MWH Monitor — M9	.61
Table 72. Multi-Monitoring — M10	.61
Table 73. Basic Parameters — P1	.62
Table 74. Basic Setting — P2.1	.62
Table 75. Digital Input — P2.2	.63
Table 76. Preset Speed — P2.3	.65
Table 77. AI1 Settings — P2.4	.65
Table 78. AI2 Settings — P2.5	.65
Table 79. Digital Output — P3.1	.66

List of tables, continued

Table 80. Supervisions — P3.2	.67
Table 81. Analog Output 1 — P3.3	.68
Table 82. Analog Output 2 — P3.4	.69
Table 83. Basic Setting — P4.1	.69
Table 84. Brake — P4.2	.70
Table 85. Skip Frequency — P4.3	.70
Table 86. Energy Savings Calc — P4.4	.70
Table 87. Basic Setting — P5.1	.71
Table 88. Second Motor Parameter — P5.2	.71
Table 89. Motor — P6.1	.71
Table 90. Drive — P6.2	.73
Table 91. Communication — P6.3	.73
Table 92. Auto Restart — P6.4	.73
Table 93. Basic Setting — P7.1	.74
Table 94. Monitor — P7.2	.75
Table 95. Basic — P7.3.1	.75
Table 96. Setpoint 1 — P7.3.2	.75
Table 97. Setpoint 2 — P7.3.3	.76
Table 98. Basic — P7.4.1	.76
Table 99. Feedback 1 — P7.4.2	.77
Table 100. Feedback 2 — P7.4.3	.77
Table 101. Basic — P7.5.1	.77
Table 102. Feedforward 1 — P7.5.2	.78
Table 103. Feedforward 2 — P7.5.3	.78
Table 104. Basic Setting — P8.1	.78
Table 105. Monitor — P8.2	.79
Table 106. Basic — P8.3.1	.79
Table 107. Setpoint 1 — P8.3.2	.79
Table 108. Setpoint 2 — P8.3.3	.80
Table 109. Basic — P8.4.1	.80
Table 110. Feedback 1 — P8.4.2	.80
Table 111. Feedback 2 — P8.4.3	.81
Table 112. Basic — P8.5.1	.81
Table 113. Feedforward 1 — P8.5.2	.81
Table 114. Feedforward 2 — P8.5.3	.81
Table 115. Fire Mode — P9	.82
Table 116. Basic Setting — P10.1	.82
Table 117. Redundant Drive — P10.2	.83
Table 118. Interval 1 — P11.1	.83
Table 119. Interval 2 — P11.2	.83

List of tables, continued

Table 120. Interval 3 — P11.383

Table 121. Interval 4 — P11.484

Table 122. Interval 5 — P11.584

Table 123. Timer — P11.684

Table 124. FB Process Data Input Sel — P12.184

Table 125. FB Process Data Output Sel — P12.2.85

Table 126. Basic Setting — P12.3.186

Table 127. Modbus RTU — P12.3.286

Table 128. BACnet MS/TP — P12.3.3.87

Table 129. Basic Setting — P12.4.187

Table 130. Modbus TCP — P12.4.287

Table 131. BACnet IP — P12.4.3.88

Table 132. Basic Setting — P13.188

Table 133. Version Info — P13.290

Table 134. Application Info — P13.3.91

Table 135. User Info — P13.4.91

Table 136. Operate Mode — O91

Table 137. Advanced Application Default I/O Configuration94

Table 138. Drive Communication Ports95

Table 139. Basic — M196

Table 140. IO Status — M2.96

Table 141. Optional Boards — M397

Table 142. Energy Savings — M4.97

Table 143. FB Monitor Menu — M5.97

Table 144. PID Monitor — M698

Table 145. Timer/Interval Control — M7.99

Table 146. User Defined Output — M899

Table 147. MWH Monitor — M9.99

Table 148. Multi-Monitoring — M10.99

Table 149. Basic Parameters — P1.99

Table 150. Basic Setting — P2.1.100

Table 151. Digital Input — P2.2.101

Table 152. Preset Speed — P2.3103

Table 153. Preset Speed — P2.3103

Table 154. Preset Speed — P2.3103

Table 155. Digital Output — P3.1104

Table 156. Supervisions — P3.2.105

Table 157. Supervisions — P3.2106

Table 158. Analog Output 2 — P3.4.107

Table 159. Logic Function — P3.5107

Table 160. Basic Setting — P4.1.108

Table 161. Brake — P4.2.109

Table 162. Skip Frequency — P4.3.109

List of tables, continued

Table 163. Energy Savings Calc — P4.4	109
Table 164. Basic Setting — P5.1	109
Table 165. Second Motor Parameter — P5.2	110
Table 166. Motor — P6.1	110
Table 167. Drive — P6.2	112
Table 168. Communication — P6.3	112
Table 169. Auto Restart — P6.4	112
Table 170. Basic Setting — P7.1	113
Table 171. Monitor — P7.2	114
Table 172. Basic — P7.3.1	114
Table 173. Setpoint 1 — P7.3.2	115
Table 174. Setpoint 2 — P7.3.3	115
Table 175. Basic — P7.4.1	116
Table 176. Feedback 1 — P7.4.2	116
Table 177. Feedback 2 — P7.4.3	116
Table 178. Basic — P7.5.1	116
Table 179. Feedforward 1 — P7.5.2	117
Table 180. Feedforward 2 — P7.5.3	117
Table 181. Basic Setting — P8.1	117
Table 182. Monitor — P8.2	118
Table 183. Basic — P8.3.1	118
Table 184. Setpoint 1 — P8.3.2	118
Table 185. Setpoint 2 — P8.3.3	119
Table 186. Basic — P8.4.1	119
Table 187. Feedback 1 — P8.4.2	119
Table 188. Feedback 2 — P8.4.3	119
Table 189. Basic — P8.5.1	120
Table 190. Feedforward 1 — P8.5.2	120
Table 191. Feedforward 2 — P8.5.3	120
Table 192. Fire Mode — P9	120
Table 193. Basic Setting — P10.1	121
Table 194. Redundant Drive — P10.2	121
Table 195. Interval 1 — P11.1	121
Table 196. Interval 2 — P11.2	122
Table 197. Interval 3 — P11.3	122
Table 198. Interval 4 — P11.4	122
Table 199. Interval 5 — P11.5	122
Table 200. Timer — P11.6	123
Table 201. FB Process Data Input Sel — P12.1	123
Table 202. FB Process Data Output Sel — P12.2	123
Table 203. Basic Setting — P12.3.1	124
Table 204. Modbus RTU — P12.3.2	124
Table 205. BACnet MS/TP — P12.3.3	125

List of tables, continued

Table 206. SA Bus — P12.3.4125
Table 207. Basic Setting — P12.4.1.125
Table 208. Modbus TCP — P12.4.2126
Table 209. BACnet IP — P12.4.3126
Table 210. Basic Setting — P13.1126
Table 211. Version Info — P13.2128
Table 212. Application Info — P13.3129
Table 213. User Info — P13.4129
Table 214. Operate Mode - O129
Table 215. Active faults210
Table 216. History faults210

Safety



WARNING! **DANGEROUS ELECTRICAL VOLTAGE!**

Before commencing the installation

- Disconnect the power supply of the device
- Ensure that devices cannot be accidentally restarted
- Verify isolation from the supply
- Earth and short circuit the device
- Cover or enclose any adjacent live components
- Only suitably qualified personnel in accordance with EN 50110-1/-2 (VDE 0105 Part 100) may work on this device/system
- Before installation and before touching the device ensure that you are free of electrostatic charge
- The functional earth (FE, PES) must be connected to the protective earth (PE) or the potential equalization. The system installer is responsible for implementing this connection
- Connecting cables and signal lines should be installed so that inductive or capacitive interference does not impair the automation functions
- Install automation devices and related operating elements in such a way that they are well protected against unintentional operation
- Suitable safety hardware and software measures should be implemented for the I/O interface so that an open circuit on the signal side does not result in undefined states in the automation devices
- Ensure a reliable electrical isolation of the extra-low voltage of the 24 V supply. Only use power supply units complying with IEC 60364-4-41 (VDE 0100 Part 410) or HD384.4.41 S2
- Deviations of the input voltage from the rated value must not exceed the tolerance limits given in the specifications, otherwise this may cause malfunction and dangerous operation
- Emergency stop devices complying with IEC/EN 60204-1 must be effective in all operating modes of the automation devices. Unlatching the emergency-stop devices must not cause a restart
- Devices that are designed for mounting in housings or control cabinets must only be operated and controlled after they have been installed and with the housing closed. Desktop or portable units must only be operated and controlled in enclosed housings
- Measures should be taken to ensure the proper restart of programs interrupted after a voltage dip or failure. This should not cause dangerous operating states even for a short time. If necessary, emergency-stop devices should be implemented
- Wherever faults in the automation system may cause injury or material damage, external measures must be implemented to ensure a safe operating state in the event of a fault or malfunction (for example, by means of separate limit switches, mechanical interlocks, and so on)
- Depending on their degree of protection, adjustable frequency drives may contain live bright metal parts, moving or rotating components, or hot surfaces during and immediately after operation
- Removal of the required covers, improper installation, or incorrect operation of motor or adjustable frequency drive may cause the failure of the device and may lead to serious injury or damage
- The applicable national accident prevention and safety regulations apply to all work carried out on live adjustable frequency drives
- The electrical installation must be carried out in accordance with the relevant regulations (for example, with regard to cable cross sections, fuses, PE)
- Transport, installation, commissioning, and maintenance work must be carried out only by qualified personnel (IEC 60364, HD 384 and national occupational safety regulations)
- Installations containing adjustable frequency drives must be provided with additional monitoring and protective devices in accordance with the applicable safety regulations. Modifications to the adjustable frequency drives using the operating software are permitted
- All covers and doors must be kept closed during operation
- To reduce hazards for people or equipment, the user must include in the machine design measures that restrict the consequences of a malfunction or failure of the drive (increased motor speed or sudden standstill of motor). These measures include:
 - Other independent devices for monitoring safety-related variables (speed, travel, end positions, and so on)
 - Electrical or non-electrical system-wide measures (electrical or mechanical interlocks)
 - Never touch live parts or cable connections of the adjustable frequency drive after it has been disconnected from the power supply. Due to the charge in the capacitors, these parts may still be live after disconnection. Fit appropriate warning signs

Definitions and symbols

WARNING

This symbol indicates high voltage. It calls your attention to items or operations that could be dangerous to you and other persons operating this equipment. Read the message and follow the instructions carefully. This symbol is the “Safety Alert Symbol”. It occurs with either of two signal words: CAUTION or WARNING, as described below.

WARNING

Indicates a potentially hazardous situation which, if not avoided, can result in serious injury or death.

CAUTION

Indicates a potentially hazardous situation which, if not avoided, can result in minor to moderate injury, or serious damage to the product. The situation described in the CAUTION may, if not avoided, lead to serious results. Important safety measures are described in CAUTION (as well as WARNING).

Hazardous high voltage

WARNING

Motor control equipment and electronic controllers are connected to hazardous line voltages. When servicing drives and electronic controllers, there may be exposed components with housings or protrusions at or above line potential. Extreme care should be taken to protect against shock.

Stand on an insulating pad and make it a habit to use only one hand when checking components. Always work with another person in case an emergency occurs. Disconnect power before checking controllers or performing maintenance. Be sure equipment is properly grounded. Wear safety glasses whenever working on electronic controllers or rotating machinery.

Warnings and cautions

This manual contains clearly marked cautions and warnings which are intended for your personal safety and to avoid any unintentional damage to the product or connected appliances. Please read the information included in cautions and warnings carefully.

WARNING

The relay outputs and other I/O-terminals may have a dangerous control voltage present even when disconnected from mains.

WARNING

Be sure not to plug the Ethernet/BACnet/IP cable to the terminal under the keypad! This might harm your personal computer.

WARNING

Be sure not to plug the Modbus TCP cable to the terminal under the keypad! This might harm your personal computer.

CAUTION

Remove external control signal before resetting the fault to prevent unintentional restart of the drive.

Important safety information

Hazardous high voltage

WARNING

The components of the power unit are live when the AC drive is connected to mains potential. Coming into contact with this voltage is extremely dangerous and may cause death or severe injury.

WARNING

The motor terminals U, V, W and the brake resistor terminals are live when connected to mains, even if the motor is not running.

WARNING

After disconnecting the AC drive from the mains, wait until the indicators on the keypad go out (if no keypad is attached see the indicators on the cover). Wait 5 more minutes before doing any work on the connections. Do not open the cover before this time has expired. After expiration of this time, use a measuring equipment to absolutely ensure that no voltage is present. Always ensure absence of voltage before starting any electrical work!

WARNING

The control I/O-terminals are isolated from the mains potential. However, the relay outputs and other I/O-terminals may have a dangerous control voltage present even when disconnected from mains.

WARNING

Before connecting the AC drive to mains, confirm that the front and cable covers of drive are closed.

WARNING

During a ramp stop (see the Application Manual), the motor is still generating voltage to the drive. Therefore, do not touch the components of the AC drive before the motor has completely stopped. Wait until the indicators on the keypad go out (if no keypad is attached see the indicators on the cover). Wait additional 5 minutes before starting any work on the drive.

Important warnings

WARNING

AC drive is meant for fixed installations only.

WARNING

Do not perform any measurements when the AC drive is connected to the mains.

WARNING

The ground leakage current of AC drives exceeds 3.5 mA AC. According to standard EN61800-5-1, a reinforced protective ground connection must be ensured.

WARNING

If the AC drive is used as a part of a machine, the machine manufacturer is responsible for providing the machine with a supply disconnecting device (EN 60204-1).

WARNING

Only spare parts delivered can be used.

WARNING

At power-up, power brake or fault reset the motor will start immediately if the start signal is active, unless the pulse control for Start/Stop logic has been selected. Furthermore, the I/O functionalistic (including start inputs) may change if parameters, applications or software are changed. Disconnect, therefore, the motor if an unexpected start can cause danger.

WARNING

The motor starts automatically after automatic fault reset if the auto restart function is activated. See the Application Manual for more detailed information.

WARNING

Prior to measurements on the motor or the motor cable, disconnect the motor cable from the AC drive.

WARNING

Do not touch the components on the circuit boards. Static voltage discharge may damage the components.

WARNING

Check that the EMC level of the AC drive corresponds to the requirements of your supply network.

Additional cautions

CAUTION

The AC drive must always be grounded with an grounding conductor connected to the grounding terminal marked with. The ground leakage current exceeds 3.5 mA AC. According to EN61800-5-1, one or more of the following conditions for the associated protective circuit shall be satisfied:

- a) The protective conductor shall have a cross-sectional area of at least 10 mm² Cu or 16 mm² Al, through its total run
- b) Where the protective conductor has a cross-sectional area of less than 10 mm² Cu or 16 mm² Al, a second protective conductor of at least the same cross-sectional area shall be provided up to a point where the protective conductor has a cross-sectional area not less than 10 mm² Cu or 16 mm² Al
- c) Automatic disconnection of the supply in case of loss of continuity of the protective conductor. The cross-sectional area of every protective grounding conductor that does not form part of the supply cable or cable enclosure shall, in any case, be not less than:
 - 2.5 mm² if mechanical protection is provided or
 - 4 mm² if mechanical protection is not provided.

The ground fault protection inside the AC drive protects only the drive itself against ground faults in the motor or the motor cable. It is not intended for personal safety. The ground fault protection inside the AC drive protects only the drive itself against ground faults in the motor or the motor cable. It is not intended for personal safety. Due to the high capacitive currents present in the AC drive, fault current protective switches may not function properly.

Do not perform any voltage withstand tests on any part of the drive. There is a certain procedure according to which the tests shall be performed. Ignoring this procedure may result in damaged product.

Sécurité



AVERTISSEMENT ! TENSION ÉLECTRIQUE DANGEREUSE !

Avant de commencer l'installation

- Débrancher l'alimentation de l'appareil
- S'assurer que les dispositifs ne peuvent pas être accidentellement redémarrés
- Vérifier l'isolement de l'alimentation
- Mettre l'appareil à la terre et le protéger contre les courts-circuits
- Couvrir ou enfermer tout composant sous tension adjacent
- Seul le personnel qualifié conformément à la norme EN 50110-1/-2 (VDE 0105 Partie 100) peut travailler sur cet appareil/ce système
- Avant l'installation et avant de toucher l'appareil, s'assurer de ne porter aucune charge électrostatique
- La terre fonctionnelle (FE, PSE) doit être raccordée à la terre de protection (PE) ou la compensation de potentiel. L'installateur du système a la responsabilité d'assurer cette connexion
- Les câbles de connexion et les lignes de signal doivent être installés de façon à ce que les interférences capacitatives ou inductives ne compromettent pas les fonctions d'automatisation
- Installer les appareils d'automatisation et les éléments de fonctionnement associés de manière à ce qu'ils soient bien protégés contre tout fonctionnement accidentel
- Des dispositifs de sécurité matériels et logiciels appropriés doivent être utilisés en rapport avec l'interface des E/S afin qu'un circuit ouvert sur le côté signal ne résulte pas en états indéfinis dans les dispositifs d'automatisation
- Assurer une isolation électrique fiable sur le côté tension extra basse de l'alimentation 24 V. Utiliser uniquement des blocs d'alimentation conformes à la norme CEI 60364-4-41 (VDE 0100, partie 410) ou HD384.4.41 S2
- Les écarts entre la tension d'entrée et la tension nominale ne doivent pas dépasser les limites de tolérance indiquées dans les spécifications, au risque de provoquer un mauvais fonctionnement et une utilisation dangereuse du système
- Les dispositifs d'arrêt d'urgence conformes à la norme CEI/EN 60204-1 doivent être efficace dans tous les modes de fonctionnement des dispositifs d'automatisation. Le déverrouillage des dispositifs d'arrêt d'urgence ne doit pas entraîner un redémarrage
- Les dispositifs conçus pour un montage dans des boîtiers ou armoires de commande ne doivent être utilisés et contrôlés qu'après avoir été installés et avec le boîtier fermé. Les unités de bureau ou portatives ne doivent être utilisées et contrôlées que dans leurs boîtiers fermés
- Des mesures doivent être prises pour assurer un bon redémarrage des programmes interrompus après une chute ou une panne de tension. Ceci ne doit pas causer des états de fonctionnement dangereux, même pour un court laps de temps. Si nécessaire, des dispositifs d'arrêt d'urgence doivent être utilisés
- Quand des défaillances du système d'automatisation peuvent entraîner des blessures ou des dommages matériels, des mesures externes doivent être appliquées pour assurer un état de fonctionnement sans danger en cas de panne ou de mauvais fonctionnement (par exemple au moyen de disjoncteurs séparés, de verrouillages mécaniques, etc.)
- En fonction de leur degré de protection, les entraînements à fréquence variable peuvent contenir des pièces métalliques sous tension, des composants rotatifs ou en mouvement et des surfaces brûlantes, pendant le fonctionnement et immédiatement après l'arrêt
- Le retrait des protections requises, une installation incorrecte ou un mauvais fonctionnement du moteur ou de l'entraînement à fréquence variable peuvent causer la défaillance de l'appareil et entraîner des blessures graves et des dommages importants
- La réglementation nationale applicable en matière de sécurité et de prévention des accidents s'applique à tous les travaux effectués sur les entraînements à fréquence variable sous tension
- L'installation électrique doit être effectuée conformément aux réglementations applicables (par exemple, en ce qui concerne les sections transversales des câbles, les fusibles, la mise à la terre de protection)
- Le transport, l'installation, la mise en service et les travaux de maintenance doivent être effectués uniquement par un personnel qualifié (IEC 60364, HD 384 et règles de sécurité du travail)
- Les installations contenant des entraînements à fréquence variable doivent être équipées de dispositifs de surveillance et de protection, conformément aux réglementations applicables en matière de sécurité. Les modifications des entraînements à fréquence variable réalisées à l'aide du logiciel d'exploitation sont autorisées
- Toutes les protections et les portes doivent être maintenues fermées pendant le fonctionnement

- Pour réduire les risques d'accidents et de dommages matériels, l'utilisateur doit inclure dans la conception de la machine des mesures limitant les conséquences de panne ou de mauvais fonctionnement de l'entraînement (augmentation de la vitesse ou arrêt soudain du moteur). Ces mesures comprennent :
 - Autres dispositifs indépendants de surveillance des variables en rapport avec la sécurité (vitesse, voyages, positions d'extrémité, etc.)
 - Mesures électriques ou non électriques appliquées à l'ensemble du système (verrouillages électriques ou mécaniques)
 - Ne jamais toucher les pièces sous tension ni les connexions des câbles de l'entraînement à fréquence variable après leur déconnexion de l'alimentation. En raison de la charge dans les condensateurs, ces pièces peuvent être encore sous tension après la déconnexion. Installer les panneaux d'avertissement appropriés

Lire ce manuel en entier et s'assurer de bien comprendre les procédures avant de tenter d'installer, de configurer, d'utiliser et d'effectuer tout travail d'entretien sur cet entraînement à fréquence variable manéjar.

Définitions et symboles

AVERTISSEMENT

Ce symbole indique une haute tension. Il attire l'attention sur les éléments ou les opérations qui pourraient être dangereux pour les personnes utilisant cet équipement. Lire attentivement le message et suivre attentivement les instructions.



Ce symbole est le « symbole d'alerte de sécurité ». Il accompagne les deux termes d'avertissement suivants : MISE EN GARDE ou AVERTISSEMENT, comme décrit ci-dessous.

AVERTISSEMENT

Indique une situation potentiellement dangereuse qui, si elle n'est pas évitée, peut entraîner des blessures graves ou la mort.

MISE EN GARDE

Indique une situation potentiellement dangereuse qui, si elle n'est pas évitée, peut entraîner des blessures légères à modérées et d'importants dégâts matériels. La situation décrite dans la MISE EN GARDE peut, si elle n'est pas évitée, entraîner des conséquences graves. Des mesures de sécurité importantes sont décrites dans les MISES EN GARDE (ainsi que dans les AVERTISSEMENTS).

Haute tension dangereuse

AVERTISSEMENT

L'équipement de contrôle du moteur et les contrôleurs électroniques sont branchés sur des tensions secteur dangereuses. Lors de l'entretien des entraînements et des contrôleurs électroniques, il peut y avoir des composants exposés avec des boîtiers ou des protubérances au niveau du potentiel du réseau ou au-dessus. Toutes les précautions doivent être prises pour se protéger contre les chocs électriques.

- Se tenir sur un tapis isolant et prendre l'habitude de n'utiliser qu'une seule main pour vérifier les composants
- Toujours travailler avec une autre personne lorsqu'une situation d'urgence se produit
- Débrancher l'alimentation avant de vérifier les contrôleurs ou d'effectuer des travaux d'entretien
- S'assurer que l'équipement est correctement relié à la terre
- Porter des lunettes de sécurité lors des travaux sur les contrôleurs électroniques ou les machines rotatives

AVERTISSEMENT

Les composants de la section d'alimentation de l'entraînement restent sous tension après la coupure de la tension d'alimentation. Après la déconnexion de l'alimentation, attendre au moins cinq minutes avant de retirer le couvercle pour permettre la décharge des condensateurs du circuit intermédiaire.

Prêter attention aux avertissements signalant des dangers !



DANGER
5 MIN

AVERTISSEMENT

Risque de choc électrique – risque de blessures !
Effectuer le câblage uniquement si l'unité n'est plus sous tension.

AVERTISSEMENT

Ne pas effectuer de modifications sur l'entraînement CA lorsqu'il est connecté à l'alimentation secteur.

Avertissements et mises en garde

AVERTISSEMENT

S'assurer de mettre l'appareil à la terre en suivant les instructions de ce manuel. Les unités non mises à la terre peuvent causer des chocs électriques et des incendies.

AVERTISSEMENT

Cet équipement ne doit être installé, réglé et entretenu que par un personnel d'entretien électrique qualifié connaissant la construction et le fonctionnement de ce type d'équipement, ainsi que les risques encourus. Le non-respect de cette précaution peut entraîner la mort ou des blessures graves.

AVERTISSEMENT

Les composants à l'intérieur de l'entraînement sont sous tension lorsque l'entraînement est branché à l'alimentation. Le contact avec cette tension est extrêmement dangereux et peut causer la mort ou des blessures graves.

AVERTISSEMENT

Les bornes de phase (L1, L2, L3), les bornes du moteur (U, V, W) et les bornes de résistance de liaison CC/frein (DC-, DC+/R+, R-) sont sous tension lorsque l'entraînement est branché à l'alimentation, même si le moteur ne tourne pas. Le contact avec cette tension est extrêmement dangereux et peut causer la mort ou des blessures graves.

AVERTISSEMENT

Même si les bornes E/S de commande sont isolées de la tension secteur, les sorties de relais et les autres bornes E/S peuvent présenter une tension dangereuse même lorsque l'entraînement est débranché. Le contact avec cette tension est extrêmement dangereux et peut causer la mort ou des blessures graves.

AVERTISSEMENT

Cet équipement a un grand courant de fuite capacitif pendant le fonctionnement, ce qui peut mettre les pièces du boîtier à un niveau supérieur au potentiel de terre. Une mise à la terre appropriée, telle que décrite dans ce manuel, est nécessaire. Le non-respect de cette précaution peut entraîner la mort ou des blessures graves.

AVERTISSEMENT

Avant de mettre l'entraînement sous tension, s'assurer que les protections avant et des câbles sont fermées et attachées pour empêcher l'exposition à d'éventuelles défaillances électriques. Le non-respect de cette précaution peut entraîner la mort ou des blessures graves.

AVERTISSEMENT

Un dispositif de protection/déconnexion en amont doit être fourni, tel que requis par le code électrique national (NEC®). Le non-respect de cette précaution peut entraîner la mort ou des blessures graves.

AVERTISSEMENT

Cet entraînement peut causer un courant CC dans le conducteur de mise à la terre de protection. Lorsqu'un dispositif de protection ou de surveillance à courant résiduel est utilisé pour la protection en cas de contact direct ou indirect, seul un dispositif de type B est autorisé sur le côté alimentation de ce produit.

AVERTISSEMENT

Ne travailler sur le câblage qu'après que l'entraînement a été correctement monté et attaché.

AVERTISSEMENT

Avant d'ouvrir les couvercles de l'entraînement :

- Débrancher toute l'alimentation allant à l'entraînement, y compris l'alimentation de commande externe pouvant être présente
- Attendre un minimum de cinq minutes après l'extinction de tous les voyants du clavier. Cela permet aux condensateurs de bus CC de se décharger
- Une tension dangereuse peut rester dans les condensateurs de bus CC même si l'alimentation a été coupée. Confirmer que les condensateurs sont entièrement déchargés en mesurant la tension à l'aide d'un multimètre réglé pour mesurer la tension CC

Le non-respect de cette précaution peut entraîner la mort ou des blessures graves.

AVERTISSEMENT

L'ouverture du dispositif de protection du circuit de dérivation peut indiquer que le courant de défaut a été interrompu. Pour réduire le risque d'incendie ou de choc électrique, les pièces porteuses de courant et les autres composants du contrôleur doivent être examinés et remplacés s'ils sont endommagés. Si l'élément de courant d'un relais de surcharge a grillé, le relais de surcharge doit être intégralement remplacé.

⚠ AVERTISSEMENT

Le fonctionnement de cet équipement nécessite le respect des instructions d'installation et de fonctionnement détaillées fournies dans le manuel d'installation/de fonctionnement destiné à être utilisé avec ce produit. Ces informations sont fournies sur le CD-ROM, la disquette ou tout autre périphérique de stockage inclus dans l'emballage contenant ce dispositif. Ce support doit être conservé avec cet appareil à tout moment. Une copie papier de ces informations peut être commandée auprès du service de documentation.

⚠ AVERTISSEMENT

Avant de procéder à l'entretien de l'entraînement :

- Débrancher toute l'alimentation allant à l'entraînement, y compris l'alimentation de commande externe pouvant être présente
- Placer une étiquette « NE PAS UTILISER » sur le dispositif de déconnexion
- Verrouiller le dispositif de déconnexion en position ouverte

Le non-respect de ces instructions peut entraîner la mort ou des blessures graves.

⚠ AVERTISSEMENT

Les sorties de l'entraînement (U, V, W) ne doivent pas être connectées à la tension d'entrée ni à l'alimentation secteur, car ceci pourrait gravement endommager l'appareil et causer un incendie.

⚠ AVERTISSEMENT

Le dissipateur de chaleur et/ou le boîtier externe peuvent atteindre une température élevée.

Prêter attention aux avertissements signalant des dangers !



Surface brûlante – Risque de brûlure. NE PAS TOUCHER !

⚠ MISE EN GARDE

Toute modification électrique ou mécanique de cet entraînement sans consentement écrit préalable annule toutes les garanties, peut entraîner un danger pour la sécurité et annuler l'homologation UL®.

⚠ MISE EN GARDE

Installer cet entraînement sur une matière résistante aux flammes, telle qu'une plaque d'acier, pour réduire les risques d'incendie.

⚠ MISE EN GARDE

Installer cet entraînement sur une surface perpendiculaire capable de supporter le poids de l'entraînement et non soumise à des vibrations afin de diminuer les risques de chute et de dommage de l'entraînement, ainsi que les risques de blessures.

⚠ MISE EN GARDE

Empêcher la pénétration de corps étrangers, tels que morceaux de fils et copeaux métalliques, dans le boîtier de l'entraînement, car ceci pourrait provoquer la formation d'un arc électrique et un incendie.

⚠ MISE EN GARDE

Installer cet entraînement dans une pièce bien aérée non soumise à des températures extrêmes, à une forte humidité ou à la condensation. Éviter les endroits directement exposés au soleil ou présentant de fortes concentrations de poussières, des gaz corrosifs, des gaz explosifs, des gaz inflammables, ou des vapeurs de liquide de meulage, etc. Une installation inadéquate peut entraîner un risque d'incendie.

⚠ MISE EN GARDE

Lors de la sélection de la section transversale des câbles, prendre en compte la chute de tension dans des conditions de charge. La prise en compte d'autres paramètres relève de la responsabilité de l'utilisateur.

Il relève de la responsabilité de l'utilisateur de respecter toutes les normes électriques nationales et internationales en vigueur concernant la mise à la terre de protection de l'ensemble de l'équipement.

⚠ MISE EN GARDE

Les spécifications minimum relatives aux sections transversales des conducteurs de terre de protection indiquées dans ce manuel doivent être respectées.

Le courant de fuite de cet équipement dépasse 3,5 mA (CA). La taille minimum du conducteur de la mise à la terre de protection doit être conforme aux exigences de la norme EN 61800-5-1 et/ou aux réglementations de sécurité locales.

⚠ MISE EN GARDE

Les courants de fuite de ce convertisseur de fréquence sont supérieures à 3,5 mA (CA). Conformément à la norme CEI/EN 61800-5-1, un conducteur de mise à la terre de l'équipement supplémentaire possédant la même superficie de coupe transversale que le conducteur de mise à la terre de protection d'origine doit être branché, ou la section transversale du conducteur de mise à la terre de l'équipement doit être d'au moins 10 mm² Cu. Seul un conducteur en cuivre doit être utilisé avec cet entraînement.

MISE EN GARDE

Les entrées anti-rebond ne sont pas permises dans le schéma du circuit de sécurité. Des disjoncteurs de courant résiduel (RCD) ne peuvent être installés qu'entre le réseau de courant alternatif et l'entraînement.

MISE EN GARDE

Les entrées anti-rebond ne sont pas permises dans le schéma du circuit de sécurité. Si plusieurs moteurs sont connectés à un entraînement, des contacteurs doivent être conçus pour les moteurs individuels conformément à la catégorie d'utilisation AC-3.

Sélectionner du contacteur du moteur en fonction du courant de fonctionnement nominal du moteur à connecter.

MISE EN GARDE

Les entrées anti-rebond ne sont pas permises dans le schéma du circuit de sécurité. Une commutation entre l'entraînement et l'alimentation d'entrée doit avoir lieu dans un état sans tension.

MISE EN GARDE

Les entrées anti-rebond ne sont pas permises dans le schéma du circuit de sécurité. Risque d'incendie !

Utiliser uniquement des câbles, des interrupteurs de protection et des contacteurs indiquant le courant nominal permis.

MISE EN GARDE

Avant de connecter l'entraînement à l'alimentation secteur CA, s'assurer que les réglages de la classe de protection CEM sont correctement effectués selon les instructions de ce manuel.

- Si l'entraînement doit être utilisé dans un réseau de distribution flottant, retirer les vis au niveau des VOM et CEM. Voir « Installation dans un réseau à une phase connectée à la terre (corner-grounded) » et « Installation dans un réseau IT »
- Débrancher le filtre CEM interne lors de l'installation de l'entraînement sur un réseau IT (système d'alimentation non mis à la terre ou système d'alimentation électrique mis à la terre haute résistance [plus de 30 ohms]) pour ne pas que le système soit connecté au potentiel de terre via les condensateurs du filtre CEM. Ceci peut être une cause de dangers ou endommager l'entraînement
- Débrancher le filtre CEM interne lors de l'installation de l'entraînement sur un système TN à une phase connectée à la terre pour ne pas endommager l'entraînement

Note: Lorsque le filtre CEM interne est débranché, l'entraînement peut ne pas être conforme aux normes de compatibilité électromagnétique.

- Ne pas tenter d'installer ou de retirer les vis des VOM et CEM lorsque l'alimentation est appliquée aux bornes d'entrée de l'entraînement

Sécurité du moteur et de l'équipement

MISE EN GARDE

n'effectuer aucun test de résistance de tension ou au mégohmmètre sur toute partie de l'entraînement ou de ses composants. Un test inadéquat peut entraîner des dommages.

MISE EN GARDE

Avant tout test ou mesure du moteur ou du câble du moteur, débrancher le câble du moteur au niveau des bornes de sortie de l'entraînement (U, V, W) pour éviter d'endommager ce dernier lors des tests.

MISE EN GARDE

Ne toucher aucun composant sur les cartes de circuit. Les décharges d'électricité statique peuvent endommager les composants.

MISE EN GARDE

Avant de mettre le moteur en marche, vérifier qu'il est correctement monté et aligné avec l'équipement entraîné. S'assurer que le démarrage du moteur ne risque pas de provoquer des blessures ou d'endommager l'équipement connecté au moteur.

MISE EN GARDE

Régler la vitesse maximale du moteur (fréquence) dans l'entraînement conformément aux exigences du moteur et de l'équipement qui lui est connecté. Des réglages de fréquence maximum incorrects peuvent endommager le moteur ou l'équipement et causer des blessures.

MISE EN GARDE

Avant d'inverser le sens de rotation du moteur, veiller à ce que cela ne risque pas de provoquer des blessures ou des dommages matériels.

MISE EN GARDE

S'assurer qu'aucun condensateur de correction de puissance n'est connecté à la sortie de l'entraînement ou aux bornes du moteur pour éviter un mauvais fonctionnement de l'entraînement et des dommages potentiels.

MISE EN GARDE

S'assurer que les bornes de sortie de l'entraînement (U, V, W) ne sont pas connectées à l'alimentation secteur, ce qui pourrait causer de graves dommages à l'entraînement.

MISE EN GARDE

Lorsque les bornes de commande de deux ou plusieurs unités d'entraînement sont raccordées en parallèle, la tension auxiliaire de ces connexions de commande doit être fournie par une source unique, qui peut être soit l'une des unités, soit une alimentation externe.

MISE EN GARDE

L'entraînement démarre automatiquement après une interruption de la tension d'entrée si la commande de démarrage externe est active.

MISE EN GARDE

Ne pas commander le moteur avec le dispositif de déconnexion ; à la place, utiliser les touches de marche et d'arrêt du tableau de contrôle ou les commandes du tableau des E/S de l'entraînement. Le nombre de cycles de charge maximum permis des condensateurs CC (c'est-à-dire les mises sous tension par application de puissance) est de cinq en dix minutes.

MISE EN GARDE

Fonctionnement incorrect de l'entraînement :

- Si l'entraînement n'est pas mis en marche pendant une longue période, la performance de ses condensateurs électrolytiques sera réduite
- S'il est arrêté pour une période prolongée, le mettre en marche au moins tous les six mois pendant au moins 5 heures pour restaurer la performance des condensateurs, puis vérifier son fonctionnement. Il est recommandé de ne pas brancher l'entraînement directement sur la tension secteur. La tension doit être augmentée progressivement en utilisant une source CA réglable

Le non-respect de ces instructions peut entraîner des blessures ou des dégâts matériels.

Pour plus d'informations techniques, contacter l'usine ou le représentant commercial local.

Chapter 1—Variable Speed Drives Series III overview

This chapter describes the purpose and contents of this manual, the receiving inspection recommendations and the Open Drive catalog numbering system.

How to use this manual

The purpose of this manual is to provide you with information necessary to install, set and customize parameters, start up, troubleshoot and maintain the variable frequency drive (VFD). To provide for safe installation and operation of the equipment, read the safety guidelines at the beginning of this manual and follow the procedures outlined in the following chapters before connecting power to the VFD. Keep this operating manual handy and distribute to all users, technicians and maintenance personnel for reference.

Receiving and inspection

The VFD has met a stringent series of factory quality requirements before shipment. It is possible that packaging or equipment damage may have occurred during shipment. After receiving your VFD, please check for the following:

Check to make sure that the package includes the Instruction Leaflet, Quick Start Guide, and accessory packet. The accessory packet includes:

- Rubber grommets
- Control cable grounding clamps
- Additional grounding screw

Inspect the unit to ensure it was not damaged during shipment.

Make sure that the part number indicated on the nameplate corresponds with the catalog number on your order.

If shipping damage has occurred, please contact and file a claim with the carrier involved immediately.

If the delivery does not correspond to your order, please contact your representative.

Note: Do not destroy the packing. The template printed on the protective cardboard can be used for marking the mounting points of the VFD on the wall or in a cabinet.

Real time clock battery activation

To activate the real time clock (RTC) functionality in the VFD, the RTC battery (already mounted in the drive) must be connected to the control board.

Simply remove the primary drive cover, locate the RTC battery directly below the keypad, and connect the white 2-wire connector to the receptacle on the control board.

Figure 1. RTC battery connection



Table 1. Common abbreviations

Abbreviation	Definition
CT	Constant torque with high overload rating (150%)
VT	Variable torque with low overload rating (110%)
IH	High overload current (150%)
I _L	Low overload current (110%)
VFD	Variable Frequency Drive
RTC	Real Time Clock

Rating label

Figure 2. VS3 rating label

			
Cat No: VS3-005-4-UL1-0			
Style No: 3-4880-005UL1			
Article No: 3-4880-005UL1			
SERIES 3 VFD		Factory ID: I	
VT		Input	Output
3KW	U(V~)	380-440 3Ø	0~Vin 3Ø
	F(Hz)	50/60 Hz	0-400 Hz
	I (A)	8.4	7.6
5HP	U(V~)	440-500 3Ø	0~Vin 3Ø
	F(Hz)	50/60 Hz	0-400 Hz
	I (A)	8.4	7.6
Enclosure Rating		TYPE 1/IP 21	
User Installation Manual: LIT-12012998			
Serial NO.: 1234567890			
 NAED: 786685886053			
    SAFETY US CA E244421	 CERTIFIED		  E1296
Field installed conductors must be copper rated at 75°C			
150507 www.johnsoncontrols.com		Assembled in USA	

Carton rating label

Figure 3. VS3 carton rating label

			
Cat No: VS3-005-4-UL1-0			
Style No: 3-4880-005UL1			
Article No: 3-4880-005UL1			
SERIES 3 VFD		Factory ID: I	
VT		Input	Output
4KW	U(V~)	380-440 3Ø	0~Vin 3Ø
	F(Hz)	50/60 Hz	0-400 Hz
	I (A)	11.2	9
7.5HP	U(V~)	440-500 3Ø	0~Vin 3Ø
	F(Hz)	50/60 Hz	0-400 Hz
	I (A)	11.2	7.6
Enclosure Rating		TYPE 1/IP 21	
User Installation Manual: LIT-12012998			
Serial No: 1234567890			
 NAED: 786685886053			
    CERTIFIED	 CERTIFIED		  E1296
N.W.: 6.10KG		G.W.: 7.10KG	
150512 www.johnsoncontrols.com		Assembled in USA	

Catalog number system

Figure 4. Johnson Controls Series III VSD—catalog numbering system

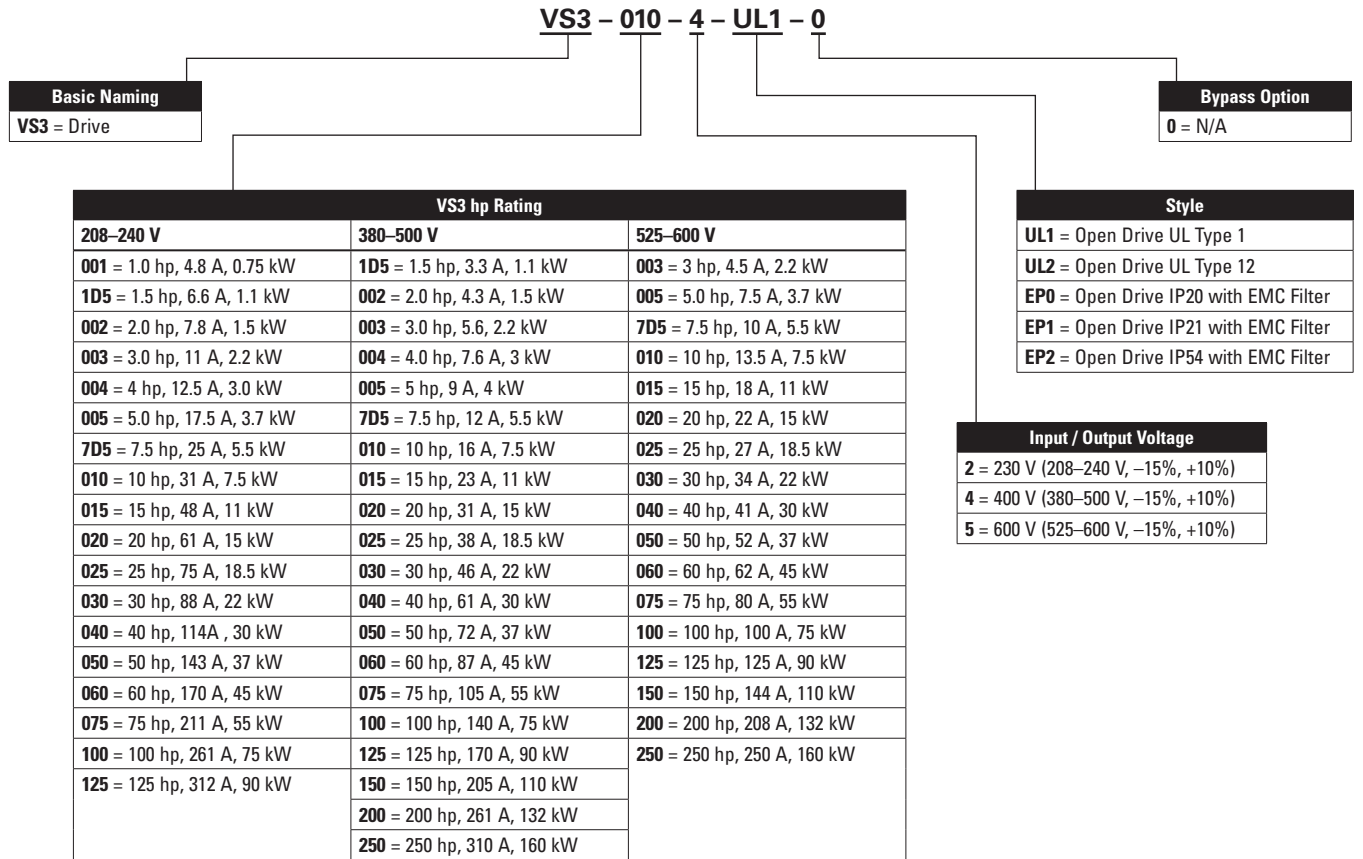

Power ratings and product selection

VS3 drives—FR0, 230 Volt

Table 2. Open Type /IP20

Frame size	Constant torque (CT)/high overload (I _H)			Variable torque (VT)/low overload (I _L)			VS3 Catalog number
	230 V, 50 Hz kW rating	230 V, 60 Hz hp	Current A	230 V, 50 Hz kW rating	230 V, 60 Hz hp	Current A	
FR0	0.55	0.75	3.7	0.75	1	4.8	VS3-324D8EB-C20C ①
	0.75	1	4.8	1.1	1.5	6.6	VS3-326D6EB-C20C ①
	1.1	1.5	6.6	1.5	2	7.8	VS3-327D8EB-C20C ①

Note: ① IP20 FR0 will be available in June 2019.

VS3 drives—FR1 - FR6, 230 Volt

Table 3. Type 1/IP21

Frame size	Constant torque (CT)/high overload (I _H)			Variable torque (VT)/low overload (I _L)			VS3 Catalog number
	230 V, 50 Hz kW rating	230 V, 60 Hz hp	Current A	230 V, 50 Hz kW rating	230 V, 60 Hz hp	Current A	
FR1	0.55	0.75	3.7	0.75	1	4.8	VS3-324D8DN-C21C
	0.75	1	4.8	1.1	1.5	6.6	VS3-326D6DN-C21C
	1.1	1.5	6.6	1.5	2	7.8	VS3-327D8DN-C21C
	1.5	2	7.8	2.2	3	11	VS3-32011DN-C21C
	2.2	3	11	3	—	12.5	VS3-32012DN-C21C
FR2	3	—	12.5	3.7	5	17.5	VS3-32017DN-C21C
	3.7	5	17.5	5.5	7.5	25	VS3-32025DN-C21C
	5.5	7.5	25	7.5	10	31	VS3-32031DN-C21C
FR3	7.5	10	31	11	15	48	VS3-32048DN-C21C
	11	15	48	15	20	61	VS3-32061DN-C21C
FR4	15	20	61	18.5	25	75	VS3-32075DN-C21C
	18.5	25	75	22	30	88	VS3-32088DN-C21C
	22	30	88	30	40	114	VS3-32114DN-C21C
FR5	30	40	114	37	50	143	VS3-32143DN-C21C
	37	50	143	45	60	170	VS3-32170DN-C21C
	45	60	170	55	75	211	VS3-32211DN-C21C
FR6	55	75	211	75	100	261	VS3-32261DN-C21C
	75	100	248	90	125	312	VS3-32312DN-C21C

Table 4. Type 12/IP54

Frame size	Constant torque (CT)/high overload (I _H)			Variable torque (VT)/low overload (I _L)			VS3 Catalog number
	230 V, 50 Hz kW rating	230 V, 60 Hz hp	Current A	230 V, 50 Hz kW rating	230 V, 60 Hz hp	Current A	
FR1	0.55	0.75	3.7	0.75	1	4.8	VS3-324D8DN-C54C
	0.75	1	4.8	1.1	1.5	6.6	VS3-326D6DN-C54C
	1.1	1.5	6.6	1.5	2	7.8	VS3-327D8DN-C54C
	1.5	2	7.8	2.2	3	11	VS3-32011DN-C54C
	2.2	3	11	3	—	12.5	VS3-32012DN-C54C
FR2	3	—	12.5	3.7	5	17.5	VS3-32017DN-C54C
	3.7	5	17.5	5.5	7.5	25	VS3-32025DN-C54C
	5.5	7.5	25	7.5	10	31	VS3-32031DN-C54C
FR3	7.5	10	31	11	15	48	VS3-32048DN-C54C
	11	15	48	15	20	61	VS3-32061DN-C54C
FR4	15	20	61	18.5	25	75	VS3-32075DN-C54C
	18.5	25	75	22	30	88	VS3-32088DN-C54C
	22	30	88	30	40	114	VS3-32114DN-C54C

Table 4. Type 12/IP54, continued

Frame size	Constant torque (CT)/high overload (I _H)			Variable torque (VT)/low overload (I _L)			VS3 Catalog number
	230 V, 50 Hz kW rating	230 V, 60 Hz hp	Current A	230 V, 50 Hz kW rating	230 V, 60 Hz hp	Current A	
FR5	30	40	114	37	50	143	VS3-32143DN-C54C
	37	50	143	45	60	170	VS3-32170DN-C54C
	45	60	170	55	75	211	VS3-32211DN-C54C
FR6	55	75	211	75	100	261	VS3-32261DN-C54C
	75	100	248	90	125	312	VS3-32312DN-C54C

VS3 drives—FR0, 380-500 Volt

Table 5. Open Type /IP20

Frame size	Constant torque (CT)/high overload (I _H)			Variable torque (VT)/low overload (I _L)			VS3 Catalog number
	400 V, 50 Hz kW rating	460 V, 60 Hz hp	Current A	400 V, 50 Hz kW rating	460 V, 60 Hz hp	Current A	
FR0	0.75	1	2.2	1.1	1.5	3.3	VS3-343D3EB-C20C ①
	1.1	1.5	3.3	1.5	2	4.3	VS3-344D3EB-C20C ①
	1.5	2	4.3	2.2	3	5.6	VS3-345D6EB-C20C ①
	2.2	3	5.6	3	5	7.6	VS3-347D6EB-C20C ①

Note: ① IP20 FR0 will be available in June 2019.

VS3 series drives—380–500 volt

Table 6. Type 1/IP21

Frame size	Constant torque (CT)/high overload (I _H)			Variable torque (VT)/low overload (I _L)			VS3 Catalog number
	400 V, 50 Hz kW rating	460 V, 60 Hz hp	Current A	400 V, 50 Hz kW rating	460 V, 60 Hz hp	Current A	
FR1	0.75	1	2.2	1.1	1.5	3.3	VS3-343D3DN-C21C
	1.1	1.5	3.3	1.5	2	4.3	VS3-344D3DN-C21C
	1.5	2	4.3	2.2	3	5.6	VS3-345D6DN-C21C
	2.2	3	5.6	3	5	7.6	VS3-347D6DN-C21C
	3	5	7.6	4	–	9	VS3-349D0DN-C21C
	4	–	9	5.5	7.5	12	VS3-34012DN-C21C
FR2	5.5	7.5	12	7.5	10	16	VS3-34016DN-C21C
	7.5	10	16	11	15	23	VS3-34023DN-C21C
	11	15	23	15	20	31	VS3-34031DN-C21C
FR3	15	20	31	18.5	25	38	VS3-34038DN-C21C
	18.5	25	38	22	30	46	VS3-34046DN-C21C
	22	30	46	30	40	61	VS3-34061DN-C21C
FR4	30	40	61	37	50	72	VS3-34072DN-C21C
	37	50	72	45	60	87	VS3-34087DN-C21C
	45	60	87	55	75	105	VS3-34105DN-C21C
FR5	55	75	105	75	100	140	VS3-34140DN-C21C
	75	100	140	90	125	170	VS3-34170DN-C21C
	90	125	170	110	150	205	VS3-34205DN-C21C
FR6	110	150	205	132	200	261	VS3-34261DN-C21C
	150	200	245	160	250	310	VS3-34310DN-C21C

Table 7. Type 12/IP54

Frame size	Constant torque (CT)/high overload (I _H)			Variable torque (VT)/low overload (I _L)			VS3 Catalog number
	400 V, 50 Hz kW rating	460 V, 60 Hz hp	Current A	400 V, 50 Hz kW rating	460 V, 60 Hz hp	Current A	
FR1	0.75	1	2.2	1.1	1.5	3.3	VS3-343D3DN-C54C
	1.1	1.5	3.3	1.5	2	4.3	VS3-344D3DN-C54C
	1.5	2	4.3	2.2	3	5.6	VS3-345D6DN-C54C
	2.2	3	5.6	3	5	7.6	VS3-347D6DN-C54C
	3	5	7.6	4	–	9	VS3-349D0DN-C54C
	4	–	9	5.5	7.5	12	VS3-34012DN-C54C
FR2	5.5	7.5	12	7.5	10	16	VS3-34016DN-C54C
	7.5	10	16	11	15	23	VS3-34023DN-C54C
	11	15	23	15	20	31	VS3-34031DN-C54C
FR3	15	20	31	18.5	25	38	VS3-34038DN-C54C
	18.5	25	38	22	30	46	VS3-34046DN-C54C
	22	30	46	30	40	61	VS3-34061DN-C54C
FR4	30	40	61	37	50	72	VS3-34072DN-C54C
	37	50	72	45	60	87	VS3-34087DN-C54C
	45	60	87	55	75	105	VS3-34105DN-C54C
FR5	55	75	105	75	100	140	VS3-34140DN-C54C
	75	100	140	90	125	170	VS3-34170DN-C54C
	90	125	170	110	150	205	VS3-34205DN-C54C
FR6	110	150	205	132	200	261	VS3-34261DN-C54C
	150	200	245	160	250	310	VS3-34310DN-C54C

VS3 drives—600 volt

Table 8. Type 1/IP21

Frame size	Constant torque (CT)/high overload (I _H)			Variable torque (VT)/low overload (I _L)			VS3 Catalog number
	600 V, 60 Hz kW rating	600 V, 60 Hz hp	Current A	600 V, 60 Hz kW rating	600 V, 60 Hz hp	Current A	
FR1	1.5	2	3.3	2.2	3	4.5	VS3-354D5DN-C21C
	2.2	3	4.5	3.7	5	7.5	VS3-357D5DN-C21C
	3.7	5	7.5	5.5	7.5	10	VS3-35010DN-C21C
FR2	5.5	7.5	10	7.5	10	13.5	VS3-35013DN-C21C
	7.5	10	13.5	11	15	18	VS3-35018DN-C21C
	11	15	18	15	20	22	VS3-35022DN-C21C
FR3	15	20	22	18.5	25	27	VS3-35027DN-C21C
	18.5	25	27	22	30	34	VS3-35034DN-C21C
	22	30	34	30	40	41	VS3-35041DN-C21C
FR4	30	40	41	37	50	52	VS3-35052DN-C21C
	37	50	52	45	60	62	VS3-35062DN-C21C
	45	60	62	55	75	80	VS3-35080DN-C21C
FR5	55	75	80	75	100	100	VS3-35100DN-C21C
	75	100	100	90	125	125	VS3-35125DN-C21C
	90	125	125	110	150	144	VS3-35144DN-C21C
FR6	110	150	144	150	200	208	VS3-35208DN-C21C
	150	200	208	187	250	250	VS3-35250DN-C21C

Table 9. Type 12/IP54

Frame size	Constant torque (CT)/high overload (I _H)			Variable torque (VT)/low overload (I _L)			VS3 Catalog number
	600 V, 60 Hz kW rating	600 V, 60 Hz hp	Current A	600 V, 60 Hz kW rating	600 V, 60 Hz hp	Current A	
FR1	1.5	2	3.3	2.2	3	4.5	VS3-354D5DN-C54C
	2.2	3	4.5	3.7	5	7.5	VS3-357D5DN-C54C
	3.7	5	7.5	5.5	7.5	10	VS3-35010DN-C54C
FR2	5.5	7.5	10	7.5	10	13.5	VS3-35013DN-C54C
	7.5	10	13.5	11	15	18	VS3-35018DN-C54C
	11	15	18	15	20	22	VS3-35022DN-C54C
FR3	15	20	22	18.5	25	27	VS3-35027DN-C54C
	18.5	25	27	22	30	34	VS3-35034DN-C54C
	22	30	34	30	40	41	VS3-35041DN-C54C
FR4	30	40	41	37	50	52	VS3-35052DN-C54C
	37	50	52	45	60	62	VS3-35062DN-C54C
	45	60	62	55	75	80	VS3-35080DN-C54C
FR5	55	75	80	75	100	100	VS3-35100DN-C54C
	75	100	100	90	125	125	VS3-35125DN-C54C
	90	125	125	110	150	144	VS3-35144DN-C54C
FR6	110	150	144	150	200	208	VS3-35208DN-C54C
	150	200	208	187	250	250	VS3-35250DN-C54C

Chapter 2—Keypad overview

The keypad is the interface between the drive and the user. It features an LCD display, 3 LED lights and 11 buttons. With the control keypad, it is possible to control the speed of a motor, to supervise the state of the equipment and to set the frequency converter's parameters. See **Figure 5**.

Figure 6. Keypad and display

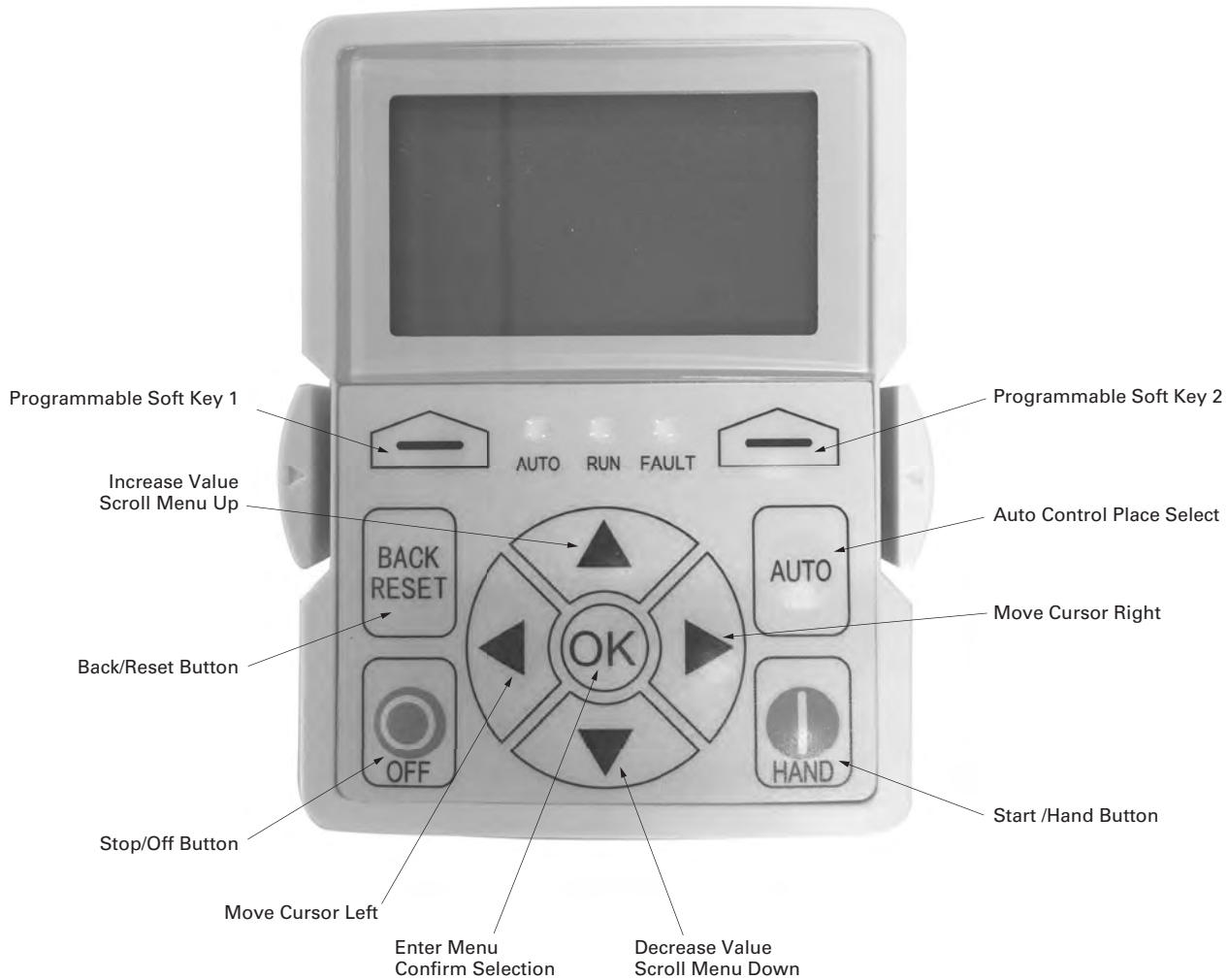

Keypad buttons

Buttons description

Table 10. Keypad buttons









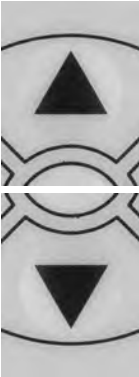

Icon	Button	Description
	Soft key 1, Soft key 2	<p>Soft key 1, soft key 2:</p> <p>The functions of these two buttons shall be the following:</p> <ul style="list-style-type: none"> • Forward/Reverse, this shall change motor's run direction. • Menu, this shall return to main menu. • Details, this shall display the details of the fault. • Bypass, this shall make drive go into bypass. • Jog, this shall activate jog. Jog can enabled via press OK Key and Soft2 Key(When the Soft2Key is Jog) and disabled via release any one of the two keys. • Favorite, this shall add this parameter to the Favorite menu. • Delete, this shall delete this parameter from the Favorite menu.
	Back/Reset	<p>Back/Reset:</p> <p>This button has three integrated functions. The button operates as backward button during normal mode. In edit mode, it is used as cancel operate. It is also used to reset faults when faults occur.</p> <ul style="list-style-type: none"> • Backs up one step. • Cancels Modify in edit mode. • Resets the active faults (all the active faults shall be reset by pressing this button more than 2 seconds in any page). • Hold Stop and Back Reset for 5 seconds to return drive to factory default • At Main Menu page by hitting Back/Reset takes to Default Page.
	Auto	<p>Auto:</p> <p>This button switches the drive into the auto control place.</p>
	Up Down	<p>Up and down arrows:</p> <ul style="list-style-type: none"> • Move either up or down a menu list to select the desired menu item. • Editing a parameter bit by bit, while the active digit is scrolled. • Increase/decrease the reference value of the selected parameter. • In parameter comparison mode, scroll through the parameters of which current value is different from comparison parameter value. • In parameter page when in read mode, move to the previous or next brother parameter of this parameter.

Table 10. Keypad buttons, continued

Icon	Button	Description
	Left	<p>Left arrow:</p> <ul style="list-style-type: none"> • Navigation button, movement to left when editing a parameter digit by digit. • Backs up one step. • At Main Menu page by hitting Back/Reset takes to Default Page.
	Right	<p>Right arrow:</p> <ul style="list-style-type: none"> • Enter parameter group mode. • Enter parameter mode from group mode. • Enter parameter whole edit mode when this parameter can be written. • Enter parameter bit by bit edit mode from whole edit mode. • Navigation button, movement to right when editing a parameter bit by bit.
	OK	<p>OK:</p> <ul style="list-style-type: none"> • Will clear all the fault history if pressed for more than 5 seconds (including 5 seconds) in any page. • This button is used in the parameter edit mode to save the parameter setting. • To confirm the start-up list at the end of the Start-Up Wizard. • To confirm the comparison item in parameters comparison mode. <p>The following is the same with Right key:</p> <ul style="list-style-type: none"> • Enter parameter whole edit mode when this parameter can be written. • Enter parameter group mode. • Enter parameter mode from group mode.
	Stop	<p>Stop/Off:</p> <p>This button operates as the motor stop button for normal operation and places the drive in the off control location. The default is for this button to always be active. It can be changed in parameter P4.1.3 to only when "Keypad" is selected as the control source.</p> <ul style="list-style-type: none"> • Motor stop from the keypad. • Transitions drive into a Off control location preventing start from any control source.
	Start	<p>Start/Hand:</p> <p>This button operates as motor start button for normal operation when the "Keypad" is selected as the active control source, as well as selects the Hand control place location. When Keypad is the reference place after hitting the start button, it will jump directly to the Keypad Ref Screen. Places drive into Hand Control place. Hitting start again if keypad is the control location will start the Drive.</p>

LED lights

Table 11. LED state indicators

Indicator	Description
 Run	Run: Indicates that the VFD is running and controlling the load in Drive or Bypass. Blinks when a stop command has been given but the drive is still ramping down.
 Fault	Fault: Turn on when there is one or more active drive fault(s).
 Auto	Auto: Hand/Off: If the Hand or Off control place is selected, the light will be off. Auto: If the Auto control place is selected, the light will be on.

LCD display

The keypad LCD indicates the status of the motor and the drive and any faults in motor or drive functions. On the LCD, the user sees information about the current location in the menu structure and the item displayed.

Overview

Five lines shall be displayed in the screen. General view is as following in **Figure 5**.

Figure 7. General view of LCD

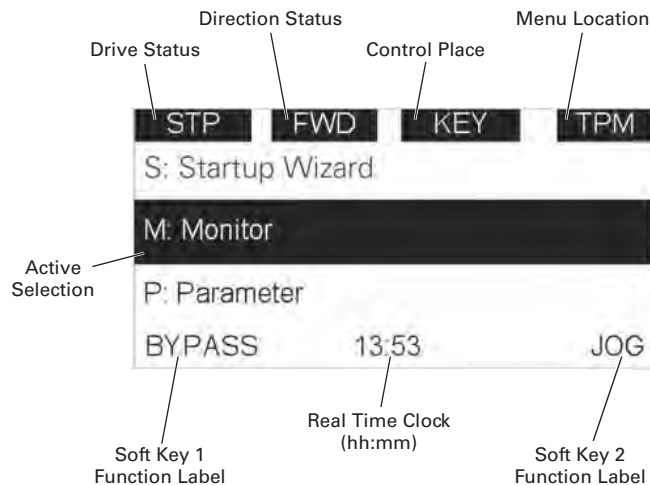

The lines definition is as below:

The first line is State line, shows:

- **RUN/STP/NRD/FIM/TFM**—If motor is running, the run state shall display “RUN”; otherwise the state display “STP.” “RUN” blinks when the stop command is sent but the drive is decelerating. “NRD” is displayed if the drive is not ready or does not have a signal “FIM” is displayed to indicate it is in Fire Mode and the drive is in a Run state. “TFM” is displayed when in the Fire Mode Test Mode and the drive is in a Run State.
- **FWD/REV/JOJ**—If the motor running direction is clockwise, display “FWD”; otherwise display “REV” “Jog” if the drive is in Jog mode the status indication will occur.
- **KEY/I/O/BPS/RBP/BUS/OFF**—If it is in bypass currently, display “BPS”; when run command is given it will got to “RBP.” otherwise, if the current control source is I/O terminal, display “I/O.” If it is keypad, then display “KEY”; otherwise display “BUS.” When indicates “OFF” it indicates the drive will not accept a command from the Hand or Auto Control place.
- **PAR/MON/FLT/OPE/QSW/FAV/TPM/BUx.**—If the current page is parameter menu, display “PAR”; If monitor menu, then display “MON”; If fault menu, then display “FLT”; If operation menu, then display “OPE”; If quick start wizard, then display “QSW”; If optional card menu, then display “BOA”; If favorite menu, then display “FAV”; If main menu, then display “TPM.” “BUx” indicates the drive being a backup drive when in the redundant drive system.

The second line is Code line, shows the menu code.

The third line is Name line, shows the menu name or parameters name.

The fourth line is Value line, shows the submenu name or parameters value.

The fifth line is Soft key line, the functions of Soft key 1 and Soft key 2 are changeable, and the real time is in the middle.

Welcome page

LCD shall show the welcome page when power on. See **Figure 6**.

Figure 8. Welcome page



Upgrade page

After welcome page, keypad will check whether there is different keypad firmware version in MCU's serial flash. If yes, then ask user whether to upgrade the keypad.

Figure 9. Upgrade page

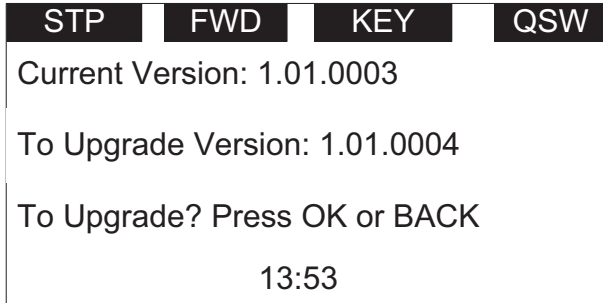

Auto backup page

If keypad is plugged into a new drive, then auto backup page will be shown to notice the user whether to do the upload/download.

Figure 10. Auto backup page

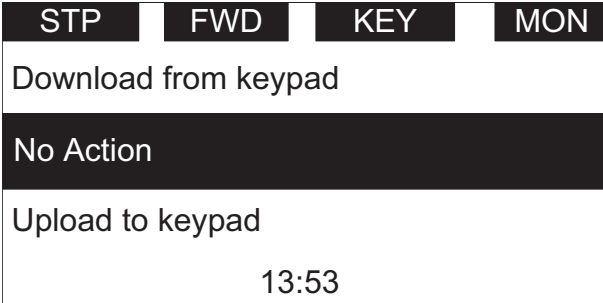

Soft key description

There are two soft key buttons. They have different definitions under different pages.

Table 12. Soft keys

Bypass Enabled

Keypad Display	Softkey 1	Softkey 2
Main menu page	Bypass	Jog
Group node page	Bypass	REVERSE/FORWARD
Parameter node page	Bypass	Null/Favorite
favorite page	Bypass	Delete
fault page	Bypass	REVERSE/FORWARD
Monitor Page	Bypass	REVERSE/FORWARD

Bypass Disabled

Keypad Display	Softkey 1	Softkey 2
Main menu page	Null	Jog
Group node page	REVERSE/FORWARD	Menu
Parameter node page	Null/Favorite	Menu
favorite page	Delete	Menu
fault page	REVERSE/FORWARD	Menu
Monitor Page	REVERSE/FORWARD	Menu

***Note:** if Para ID2412 or Para ID2413 is set to hidden it will hide this value.

1. In the main menu (root node), "JOG" shall be shown on the right. If bypass is enabled, then "BYPASS" shall be shown on the left. Otherwise, it will not be shown. See **Figure 10**

Figure 11. Main menu

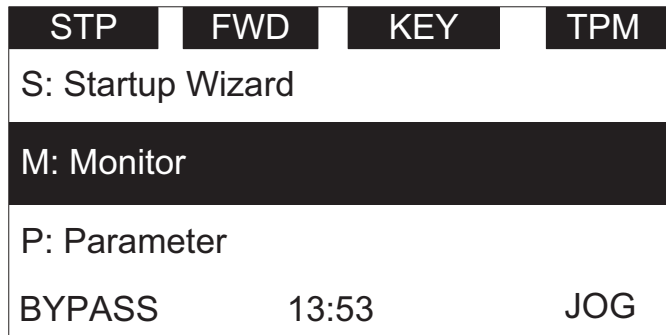

- For the parameter group, the two soft keys “REVERSE/FORWARD” and “BYPASS” shall be shown. See **Figure 11**

Figure 12. Parent node page

STP	FWD	KEY	PAR
P1: Basic Parameters			
P2: Inputs			
P3: Outputs			
BYPASS	13:53	REVERSE	

- For the parameter menu, if this parameter hasn't been added into the favorite list, two soft keys “FAVORITE” and “BYPASS” shall be shown. If it has been added into the favorite list, only one soft key “BYPASS” is shown in the right.

Figure 13. Parameter page

STP	FWD	KEY	PAR
P2.5.1			
AI2 Mode			
0 - 20mA			
BYPASS	13:53	FAVORITE	

- If one parameter has been added to the favorite list, it shall appear in the favorite menu. Then when you enter into the favorite menu, two soft keys “DELETE” and “BYPASS” shall be shown, and “DELETE” means you can delete the selected parameter from favorite list. See **Figure 13**

Figure 14. Parameter page from favorite menu

STP	FWD	KEY	FLT
P2.5.1: AI2 Mode			
M1.2: Reference Frequency			
M1.3: Motor Speed			
BYPASS	13:53		

- For the fault group, two soft keys “DETAILS” and “BYPASS” shall be shown. See **Figure 14**. For more information, see **Page 16**

Figure 15. Fault page

STP	FWD	KEY	FLT
F1.1: Fault			
Over Voltage			
04.08.12	13:53:45		
BYPASS	13:53	DETAILS	

Chapter 3—Menu overview

Main menu page

The data on the keypad are arranged in menus and sub-menus. The first menu level consists of M, P, F, B, T, O and S, and it is called the Main Menu.

Figure 16. Main menu page

STP	FWD	KEY	TPM
S: Startup Wizard			
M: Monitor			
P: Parameter			
BYPASS	13:53	JOG	

Menu navigation

This section provides basic instruction on navigating each section in the menu structure.

Figure 17. Main menu navigation

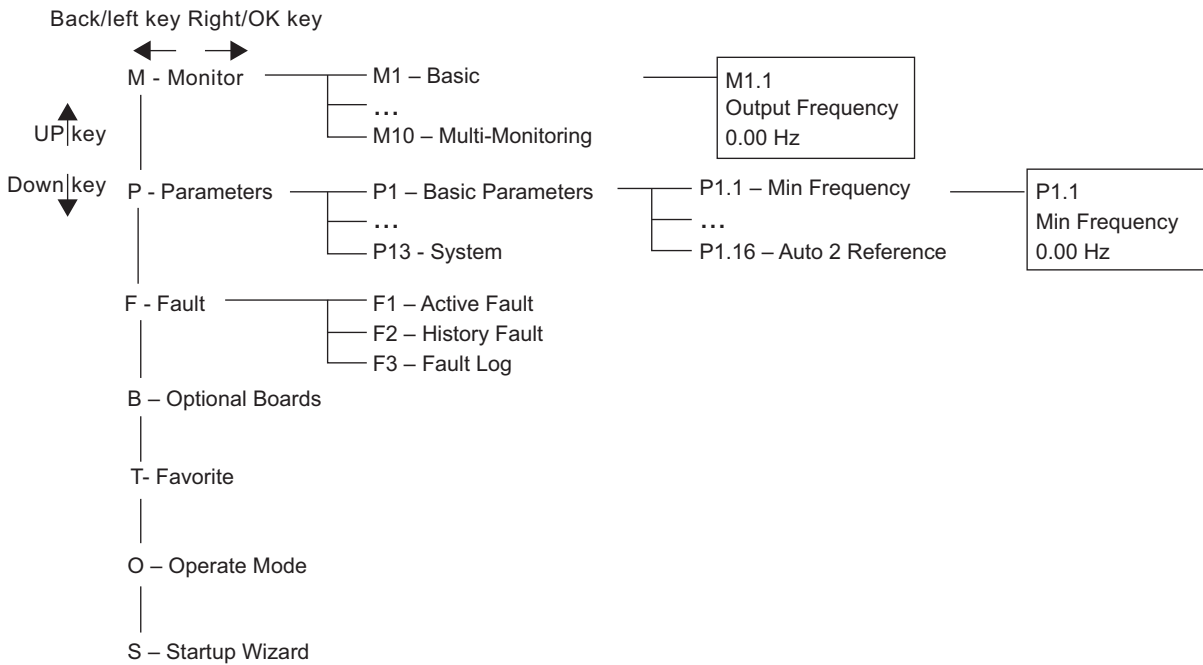

Menu structure

Table 13. Keypad menus

Item	Description	Item	Description
Monitor	M1 - Basic	Fault	F1 - Active Fault
	M2 - IO Status		F2 - History fault
	M3 - Optional Boards		F3 - Fault Log
	M4 - Energy savings	Option Boards	B1 - Slot A
	M5 - FB Monitor Menu		B2 - Slot B
	M6 - PID Monitor	Favorite	
	M7 - Timer/Interval Control	Operate Menu	O1 - Output Frequency
	M8- User Defined Output		O2 - Freq Reference
	M9 - MWH Monitor		O3 - Motor Speed
	M10 - Multi-Monitoring		O4 - Motor Current
Parameter	P1 - Basic Parameter		O5 - Motor Torque
	P2 - Inputs		O6 - Motor Power
	P3 - Outputs		O7 - Motor Voltage
	P4 - Drive Control		O8 - DC-link Voltage
	P5 - Motor Control		O9 - Unit Temperature
	P6 - Protections		O10 - Motor Temperature
	P7 - PID Controller 1		R11 - Keypad Reference
	P8 - PID Controller 2		R12 - PID1 Keypad Set Point 1
	P9 - Fire Mode		R13 - PID1 Keypad Set Point 2
	P10 - Bypass	Startup Wizard	S - Startup Wizard
	P11 - Real Time Clock		
	P12 - Communications		
	P13 - System		

Note: Will vary depending on application selected

M — Monitor

In monitor page, user shall not be able to edit the parameters except multi-monitor parameter. Multi-monitor parameters allow for displaying 3 monitor values on display. The three values can be changed to any of the listed values.

The navigation for monitor is as **Figure 17**.

Figure 18. M—Monitor

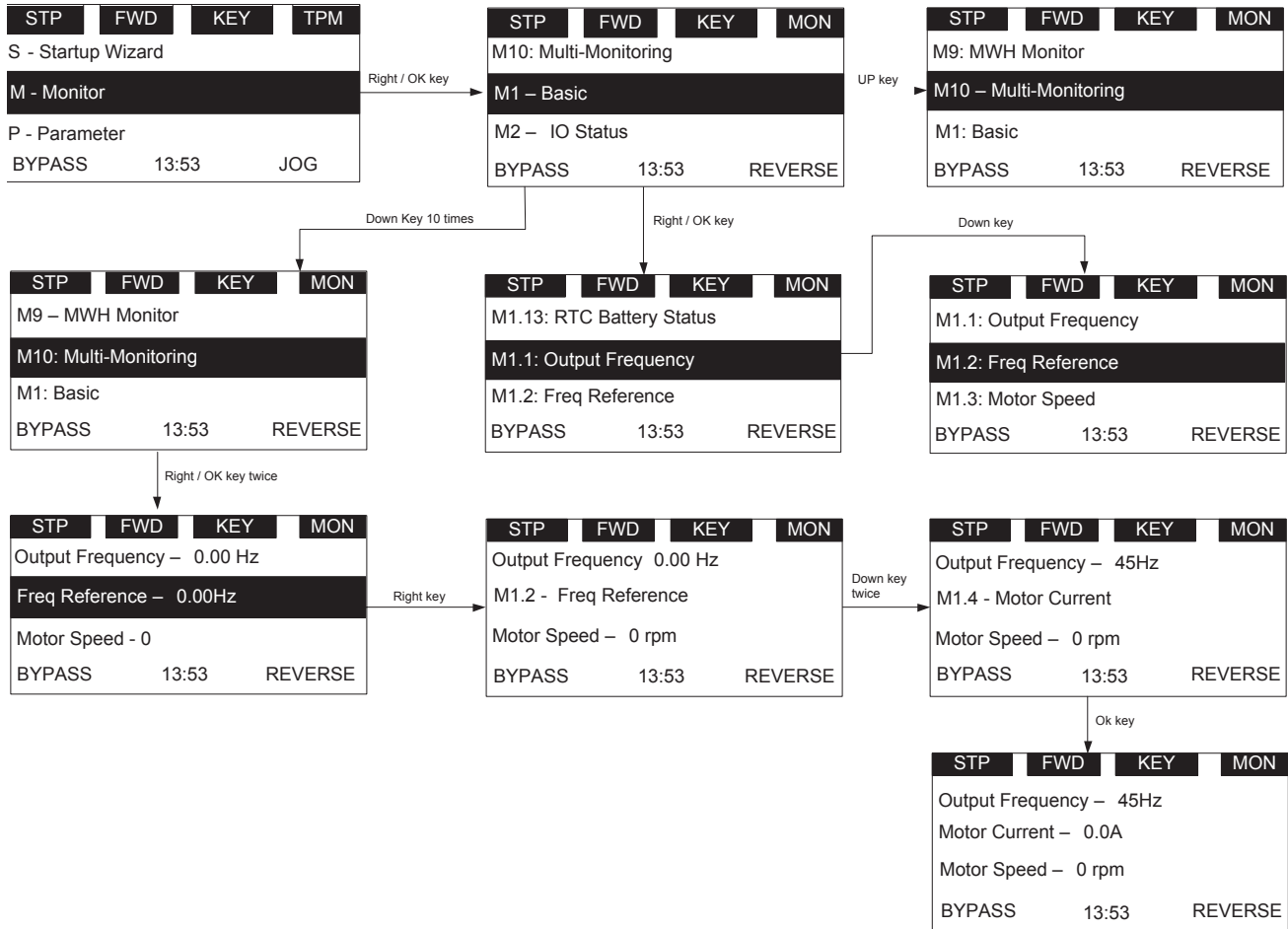

F — Fault

There are three fault pages. The first one is F1 active faults; the second one will pop-up automatically when fault occurs; the third one is F2 fault history.

If there is no active fault/history fault, then “No fault” shall be shown.

After the DETAIL soft key is pressed, the following detail information about the fault shall be shown: fault code, type, power day count, power hour count, frequency, current, voltage, power, torque, DC voltage, unit temperature, run status, direction, warning, zero speed, Mwh count, at reference.

Active fault

The navigation for active faults is as **Figure 18**.

Figure 19. Active faults

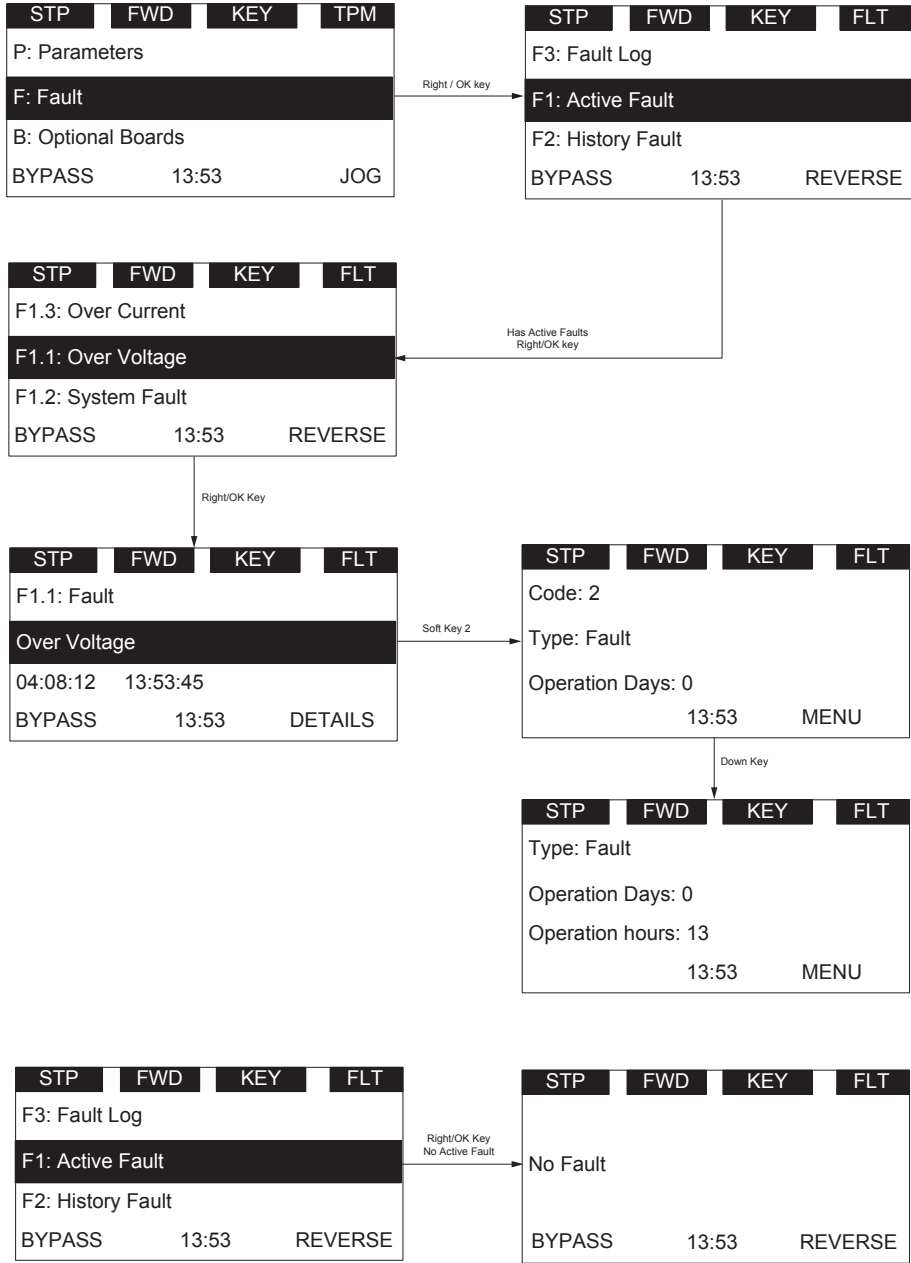

Pop-up fault

The navigation for the pop-up active fault is as **Figure 19**.

Figure 20. Pop-up active faults

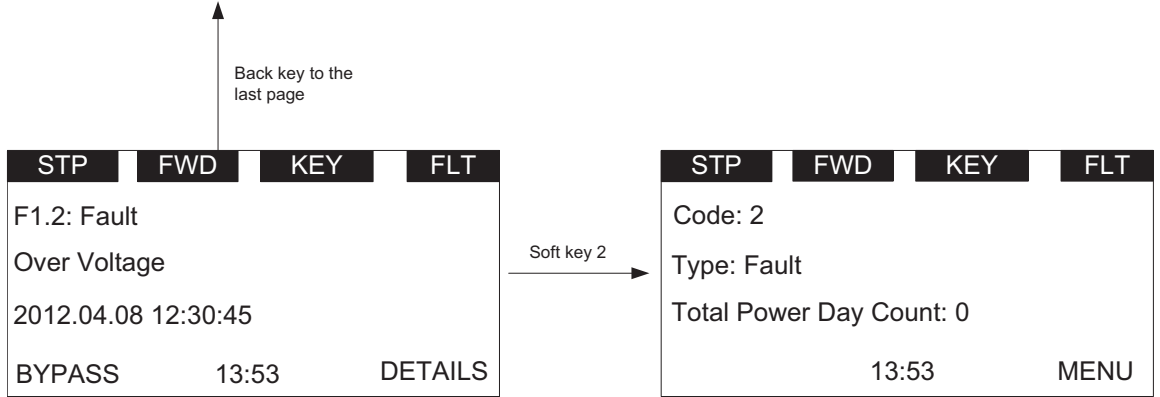

The latest active fault page shall pop up when there is a new active fault, the pop-up fault page is the same as the active fault page.

Pressing the back/reset key less than 2 seconds shall back to the last page user is watching.

Pressing the back/reset key more than 2 seconds shall reset all active faults when all the active fault condition is not satisfied.

User shall be able to navigate all the active faults by up/down key.

The page for active faults and pop-up faults are the same, except one: the response to the "Back" key. In active faults page, if the Back key is pressed, it returns to the last level menu. In pop-up faults page, it returns to the last page.

Fault history

The navigation for fault history is as **Figure 20**.

In any page, OK button is used to clear all the active faults and fault history by pressing more than 5s without password.

Figure 21. Fault history

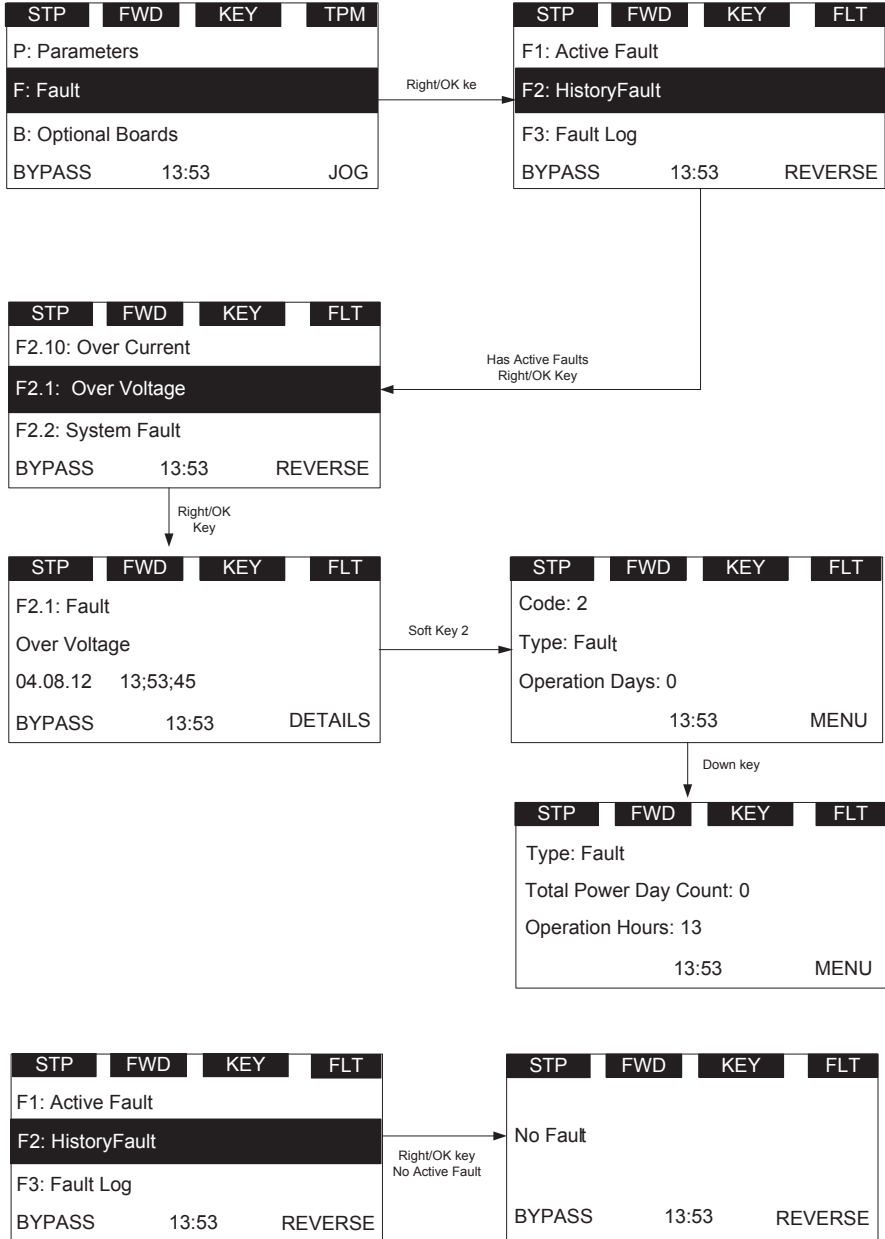

Fault Log

The Fault Log will store the last 50 faults in it with 1 being the most recent and 50 being the oldest. Only the fault code, name and time stamp are stored with these faults.

P — Parameter

The navigation for the parameter menu is shown in **Figure 21**.

In parameter page, the parameter code shall be shown in the second line (such as P1.1).

In parameter page, the parameter name shall be shown in the third line (such as Min Frequency).

In parameter page, the value of parameter and unit shall be shown in the fourth line (0.00 Hz).

If the parameter is read and write, then pressing the right key shall make the parameter value flash, which means that the value can be edited.

If the parameter is read only, then pressing the right key will not have any effect, which means that the value can't be edited.

Figure 22. Parameter setting

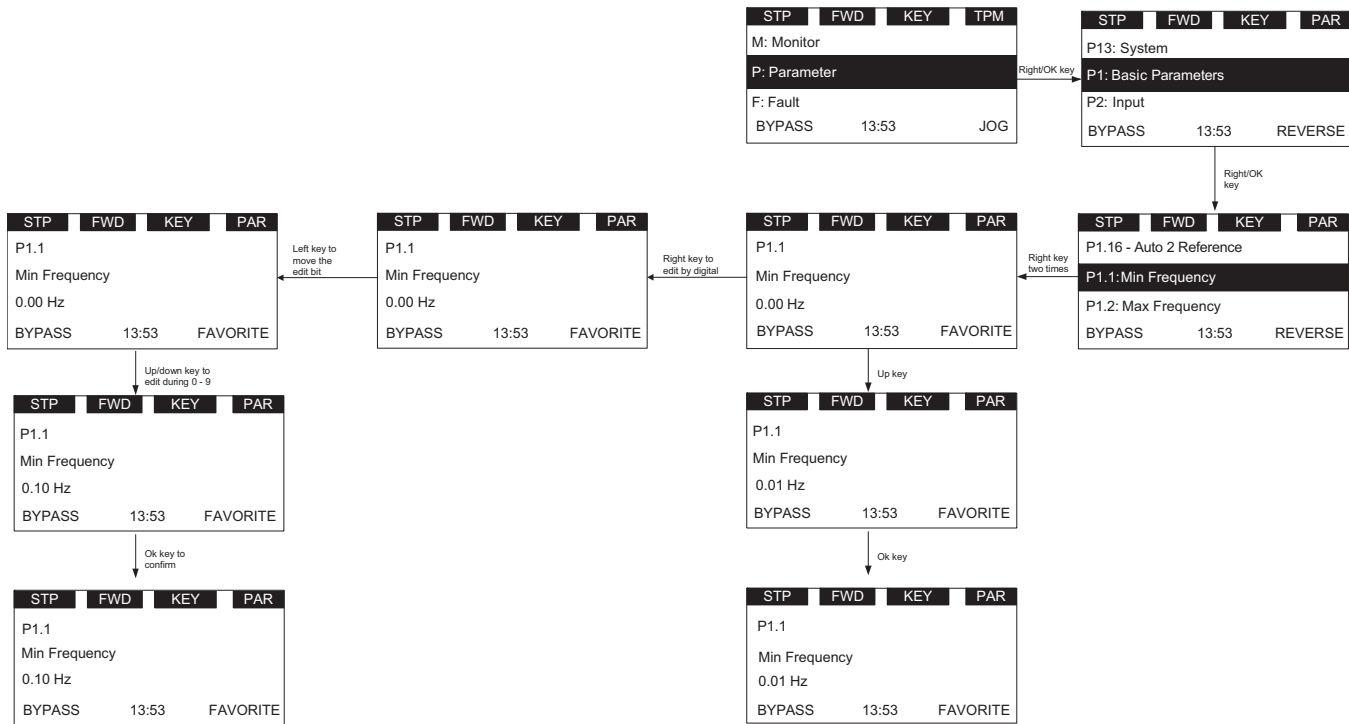

There are several special pages:

1. P13.1.3 Parameter Sets. See **Figure 22**.

User shall be able to load or store parameters. The options are as follows: Reload Defaults, Reload Set 1, Reload Set 2, Store Set 1, Store Set 2, Reset, Reload Defaults VM. The special points are:

- During this operation, “waiting...” shall flash, which means it is in process
- When it is finished, “OK” shall be shown
- Drive shall restart after default parameters are loaded
- “Reload Defaults VM” is for the sales stand. Do not use on a fully functioning drive

Figure 23. Parameter sets

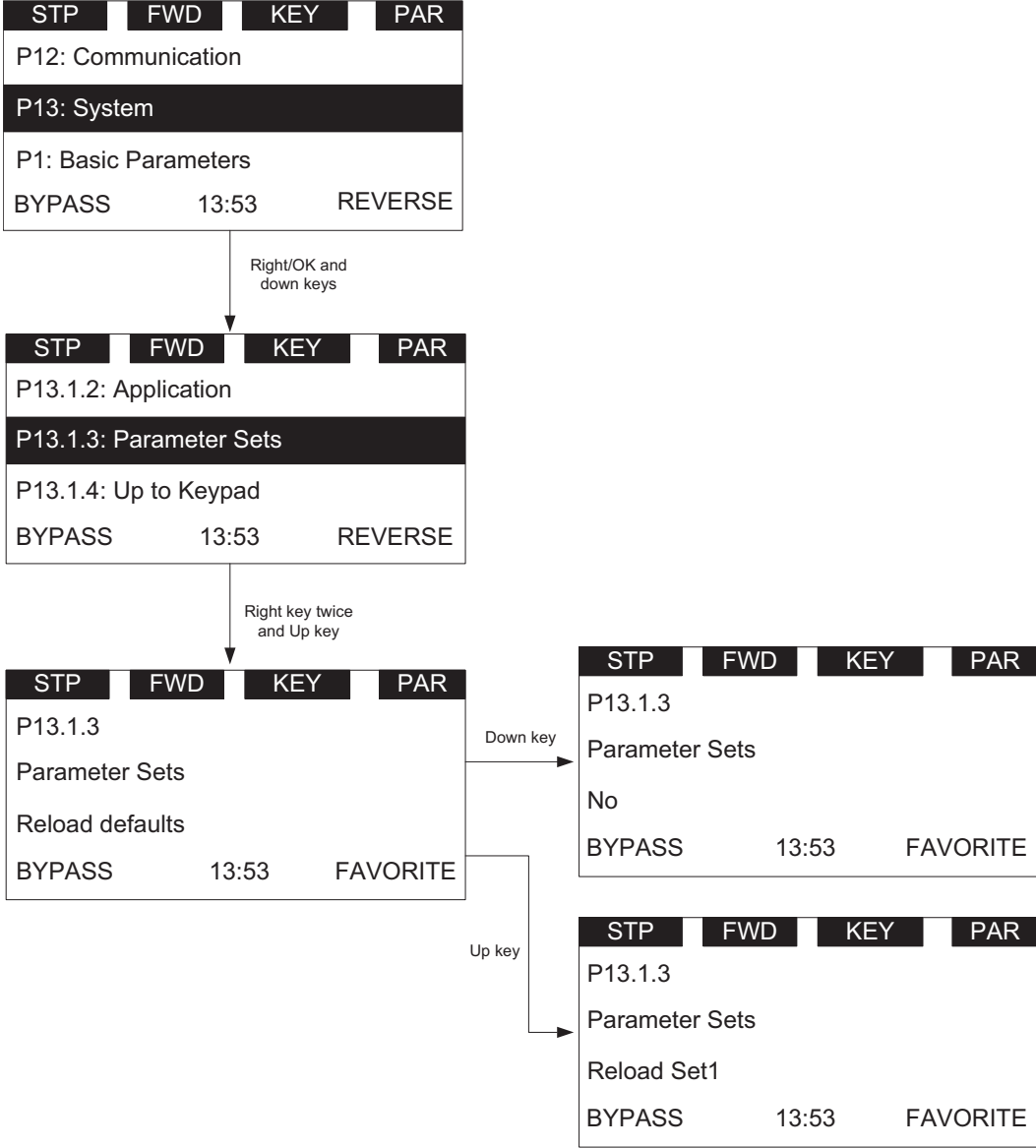

Chapter 3—Menu overview

2. Up to keypad and P13.1.5 Down from keypad

During this operation, “waiting...” shall flash, which means it is in process. When it is finished, “OK” shall be shown. This stores the parameters to keypad for transferring.

Down from keypad is to download parameters from keypad to drive. Up to keypad takes the parameters from the drive and loads them to the keypad.

Figure 24. Down from keypad

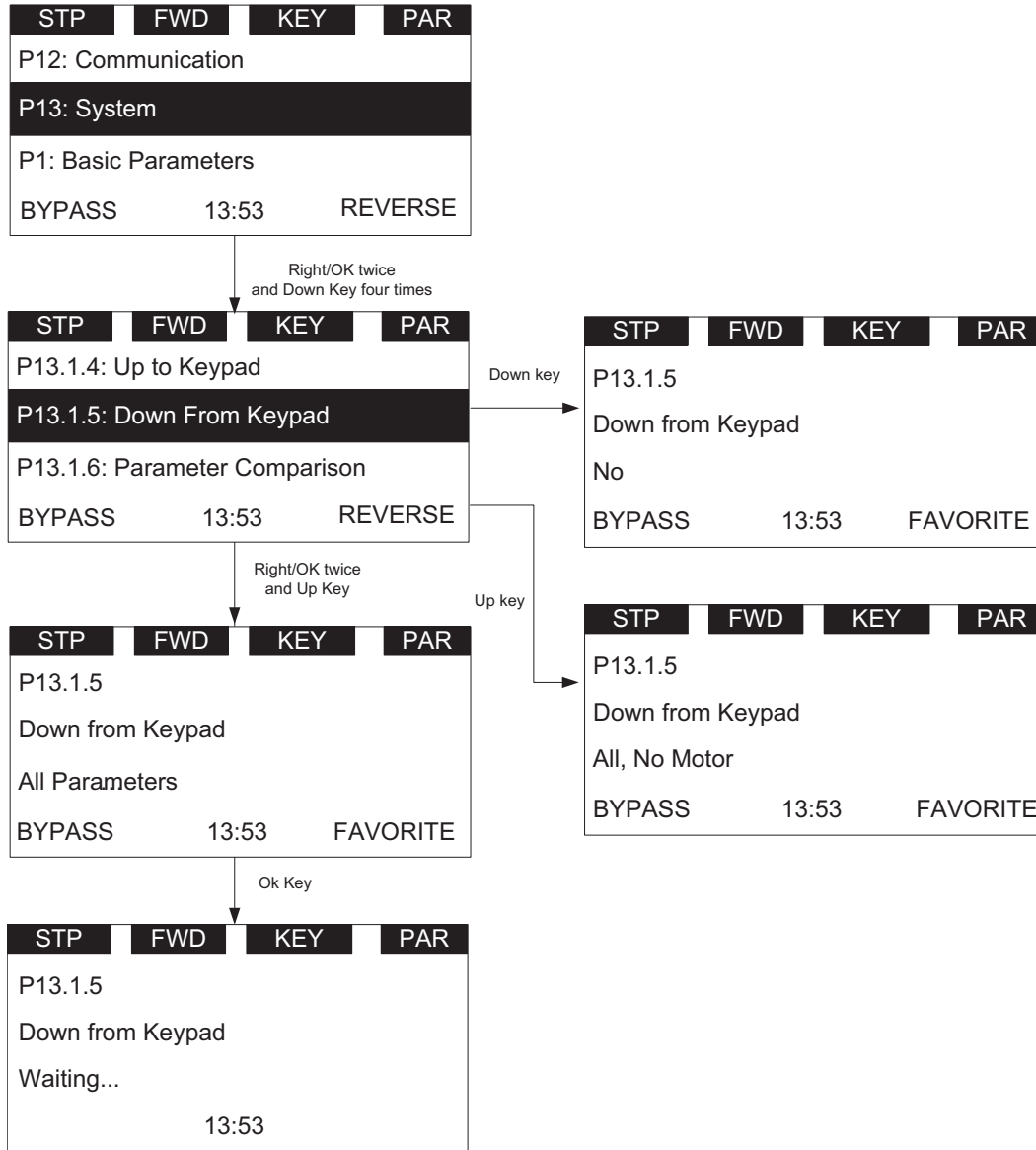

3. P13.1.6 Parameters Comparison

After the operation, the number of different parameter will be shown. Then press the right key; the first different parameter shall be shown.

The parameter name shall be shown in the second line, and the value which is from keypad/default/set1/set2 shall be shown in the third line, the current value shall be shown in the fourth line.

If the user wants to modify the current value, user shall be able to enter the edit mode by right key.

User shall be able to browse all the different parameters by up/down key.

During this operation, "waiting..." shall flash, which means it is in process.

When it is finished, "OK" shall be shown. See **Figure 24**.

Figure 25. Parameters comparison

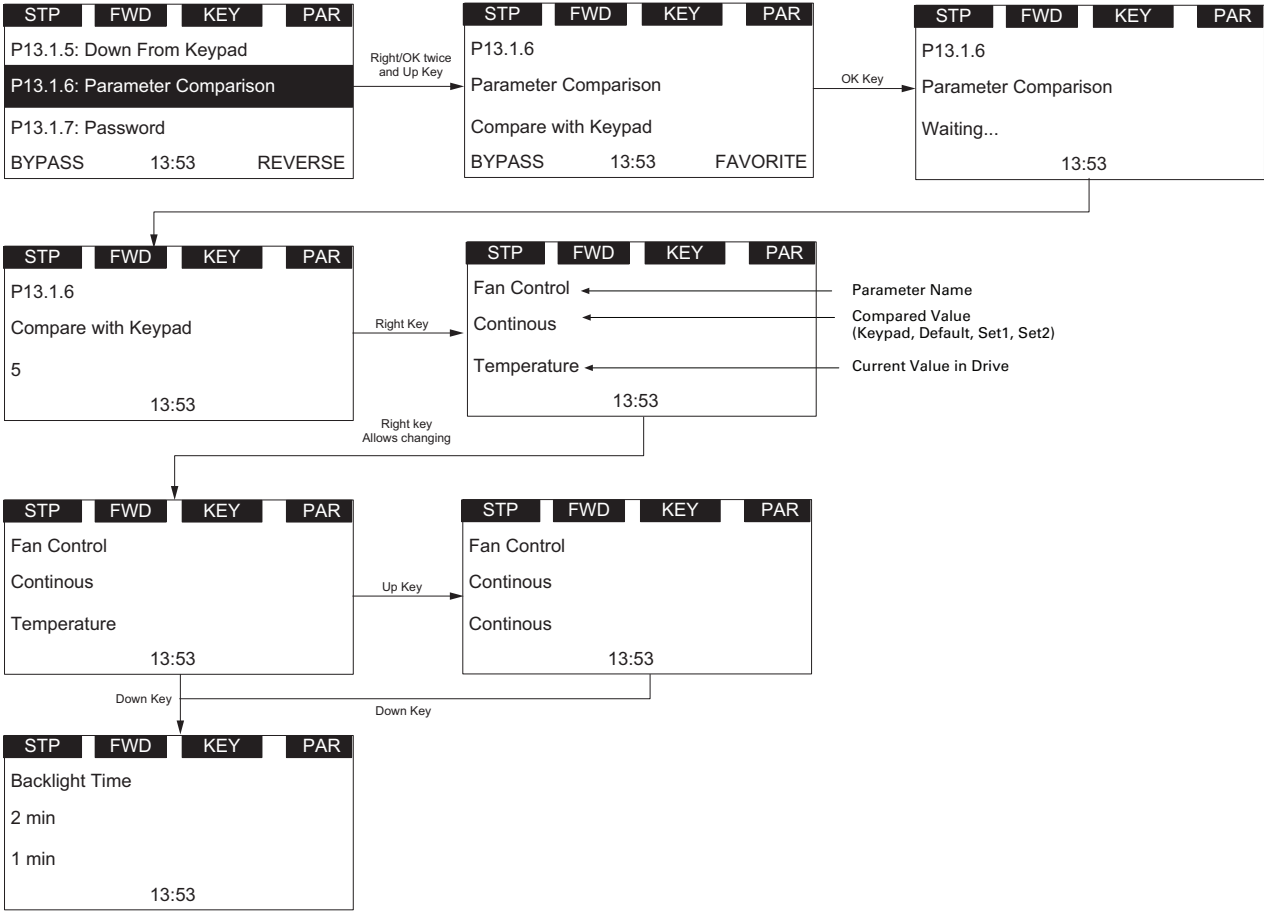

Chapter 3—Menu overview

4. P13.1.7 Password

Password protects the parameters' security. Zero means not used, otherwise in use. If password is in use, user can still see the values of parameters, but needs to enter the password before editing. User must enter current password before changing the password.

0000 shall mean that the password is not used, the password is 0000 by default.

The password range shall be 0001–9999, the setting of password and checking of password are as **Figure 25**.

Enter the password setting page. If the password is 0000, then the "Not use" shall be shown. If the password is not 0000, then the "in use" shall be shown.

If the password is in use, and user inputs the wrong password, then the "failed" shall be shown.

After "failed" is shown 3 seconds, the page shall return to the parameter read page.

If the password is in use, and user inputs the right password, then the value shall flash, which indicates that it can be edited.

Figure 26. Password

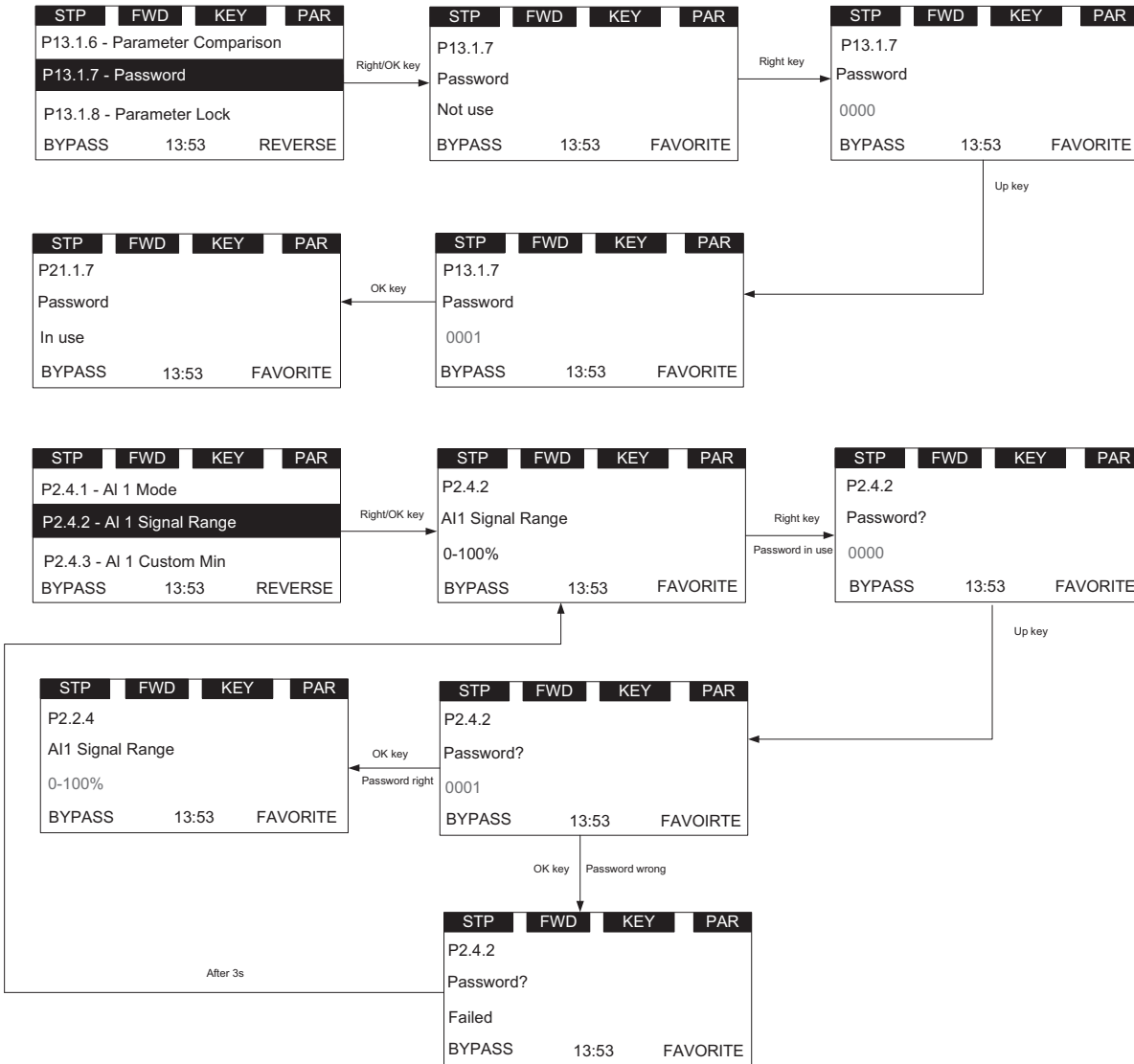

Value edit

This topic shows the methods to edit value, and what will happen to edit value when password is in use and parameter lock is enabled.

We have three methods to edit value: edit by key press-hold, edit bit by bit, edit click by click.

For details, please see **Figure 26**. For the editable parameter, press "Right" key once to enter the read mode

(just read the value of this parameter), press "Right" key again to enter the edit mode (user can modify the value of this parameter), press "Right" key again to enter the bit-by-bit edit mode.

User shall use Left/Right key to change the current editable bit. When editing one number, it increases/decreases circularly, for example, pressing Up key can change to 9 from 0.

Figure 27. Edit parameter value

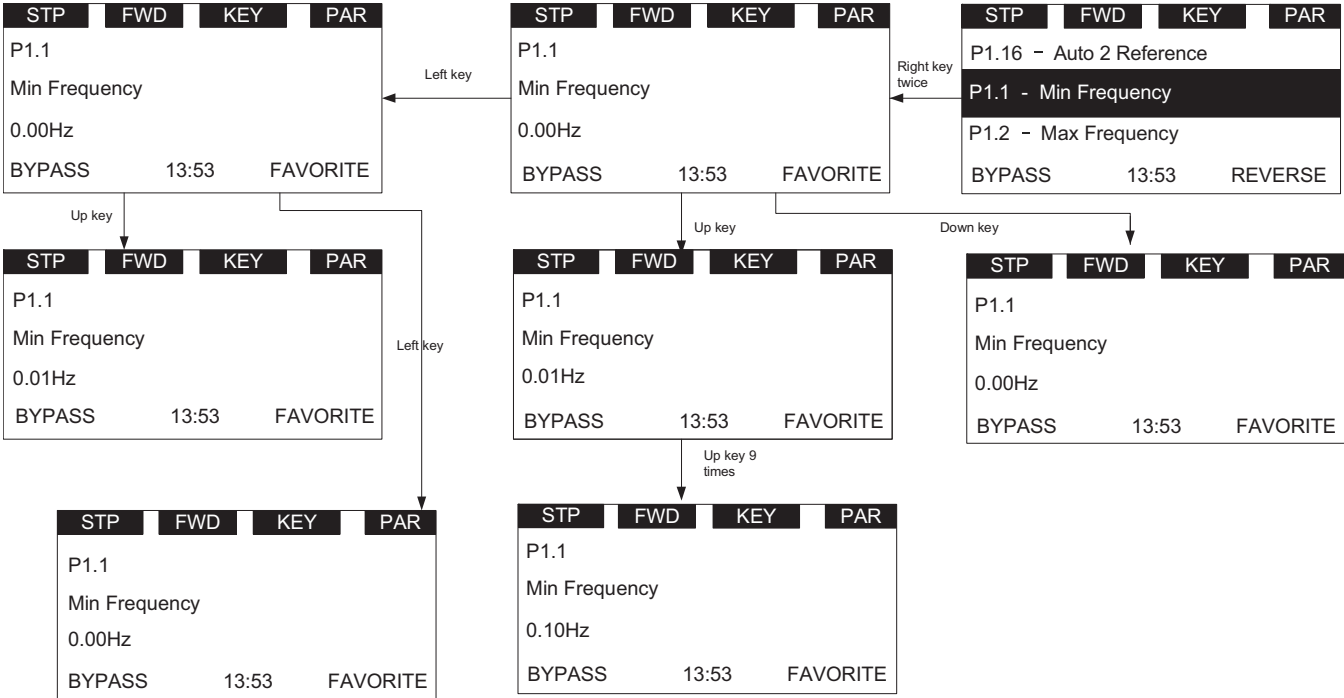

Chapter 3—Menu overview

1. If password is in use, password shall be needed to check before edit parameter value.
2. If no action in 1min, the password shall need to be checked again.
3. If Parameter locked is enabled, *Locked* shall be shown if user tries to edit the parameter.

Figure 28. Parameter locked

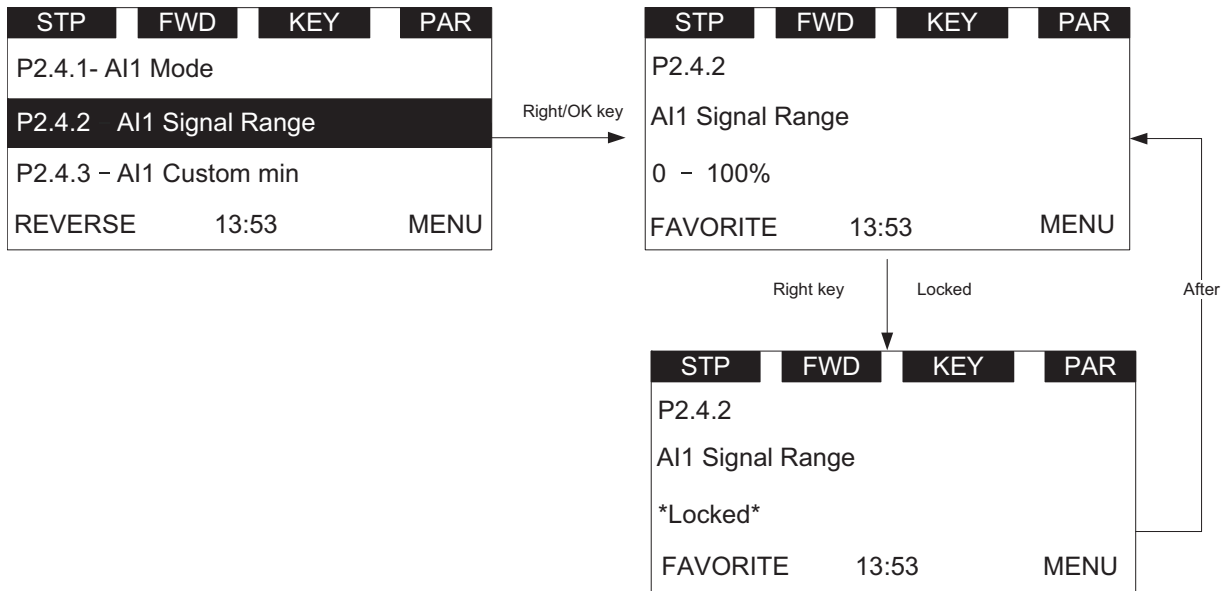

T—Favorite

Favorites collect the user's favorite parameters. User can add one parameter into favorite list by "FAVORITE" soft key, and can delete it from favorite list by "DELETE" soft key.

If a parameter has not been added into the favorite list, the soft keys "FAVORITE" will be shown in parameter page (see **Figure 12** on **Page 12**). If it has been added into the favorite list, the soft key "FAVORITE" will not be shown.

If a parameter has been added to the favorite list, it shall appear in the favorite menu. Then when you enter into the favorite menu, the soft keys "DELETE" will be shown. This allows you to remove the selected parameter from favorite list (see **Figure 12** on **Page 12**).

After one parameter is removed from favorite list, the next parameter in the favorite list will be selected by default.

Chapter 4—Startup

Startup wizard page

The Startup Wizard is a sub-menu of main menu. Once user enters into this menu, the Startup Wizard will begin.

In the Startup Wizard, you will be prompted for essential information needed by the drive so that it can start controlling your motor. During this process, you can also select the application that best suits your needs.

If user changes the Application, the drive and keypad will reset.

Startup wizard

In the *Startup Wizard*, you will be prompted for essential information needed by the drive so that it can start controlling your process. In the Wizard, you will need the following keypad buttons:



Up/Down buttons.

Use these to change value.



OK button.

Confirm selection with this button, and enter into next question.



Back/Reset button.

If this button was pressed at the first question, the Startup Wizard will be cancelled.

If this button is pressed in any step on the Startup Wizard, the Startup Wizard will be cancelled.

Once you have connected power to your frequency converter, and the Startup Wizard is enabled, follow these instructions to easily set up your drive.

Table 14. Startup wizard instructions

Item	Description	
1	Startup Wizard	Press OK?
2	Application	0 = basic 1 = PID 2 = Advanced
3	Language	0 = English 1 = Chinese 2 = Deutsch
4	Real Time Clock	yy.mm.dd hh:mm:ss
5	Daylight Saving	0 = Off 1 = EU 2 = US
6	Min Frequency	Min: 0.00Hz Max: Max Frequency
7	Max Frequency	Min: Min Frequency Max: 400.00Hz
8	Motor Nom Current	Min: 0.1A Max: 500.0A
9	Current Limit	Min: $I_h \times 1/10$ Max: $I_h \times 2$
10	Motor Nom Speed	Min: $I_h \times 1/10$ Max: $I_h \times 2$
11	Motor PF	Min: 0.30 Max: 1.0
12	Motor Nom Voltage	Min: 180V Max: 690V
13	Motor Nom Frequency	Min: 30.00 Hz Max: 400.00 Hz
14	Accel Time 1	Min: 0.1 sec Max: 3000.0 sec
15	Decel Time 1	Min: 0.1 sec Max: 3000.0 sec
16	Hand Control Place	0 = Keypad 1 = I/O Terminal Start 1 2 = I/O Terminal Start 2 3 = Feildbus
17	Hand Reference	0 = AI1 1 = AI2 2 = Slot A: AI1 3 = Slot B: AI1 4 = AI1 Joystick 5 = AI2 Joystick 6 = Keypad 7 = Feildbus 9 = Max Frequency 10 = AI1 + AI2 11 = AI1 - AI2 12 = AI2 - AI1

Table 14. Startup wizard instructions continued

Item	Description	
17	Hand Reference, continued	13 = AI1 * AI2 14 = AI1 or AI2 15 = Min(AI1,AI2) 16 = Max(AI1,AI2) 17 = PID1 Control Output 18 = PID2 Control Output
18	Auto 1 Control Place	0 = I/O terminal Start 1 1 = Fieldbus 2 = I/O terminal start 2 3 = Keypad
19	Auto 1 Reference	0 = AI1 1 = AI2 2 = Slot A: AI1 3 = Slot B: AI1 4 = AI1 Joystick 5 = AI2 Joystick 6 = Keypad 7 = Fieldbus 9 = Max Frequency 10 = AI1 + AI2 11 = AI1 - AI2 12 = AI2 - AI1 13 = AI1 * AI2 14 = AI1 or AI2 15 = Min(AI1,AI2) 16 = Max(AI1,AI2) 17 = PID1 Control Output 18 = PID2 Control Output
20	Bypass Enabled	0 = Disabled 1 = Enabled
21	Application Mini-Wizard	Press OK?

Now the Startup Wizard is done. It will not show again at the next power up. If you want to reset it, please select it from the main menu ("Startup Wizard").

PID and Advanced Application Mini-Wizard

The PID Mini-Wizard is activated in the Quick Setup menu. This Wizard assumes that you are going to use the PID controller in the "one feedback/one setpoint" mode. The control place will be I/O A and the default process unit "%". The PID Mini-Wizard asks for the following values to be set:

Table 15. PID Mini-Wizard values

Item	Description	
20	PID 1 Process Unit	Select Units
21	PID1 Process Unit Min	Min: -99999.99 Max: PID1 Process Unit Max
22	PID1 Process Unit Max	Min: PID1 Process Unit Min Max: 99999.99
23	PID 1 Set Point 1 Source	Select Function
24	PID 1 Keypad Set Point 1	Min: PID 1 Process Unit Min Max: PID 1 Process Unit Max
25	PID 1 Feedback 1 Source	Select Input
26	PID 1 Feedback 1 Min	Min: -200% Max: 200%
27	PID 1 Feedback 1 Max	Min: -200% Max: 200%

Chapter 5—Basic application

The Basic Application is designed for preloaded application sets for use with HVAC specific terminology and functions. It has the patent Active Energy Control algorithm that will improve your efficiency as well as minimize losses in your motor throughout the defined speed range. It provides the ability for the user to define its Hand and Auto control and reference signals with the standard Off condition as well. In addition there is the ability to scale the analog input and output signals to be read based off the desired motor response. There are also 8 digital inputs, 3 relay outputs, and 1 digital output that can be programmed to allow for control schemes that require the drive to have certain functions. It provides full customization on the motor control sequence with the ability to be in frequency or speed control mode, and tuning of the V/Hz curve can be selected. Drive/Motor protections can be customized to defined actions for added user control. Below is a list of other features that are available in the Basic Application.

Basic Application includes functions:

- Bypass Control
- Fire Mode
- Pre heat/cold weather mode
- Hand/Off/Auto in individual button for easy change of control mode.
- Programmable Protections
- Programmable digital/analog input/output function
- Programmable start/stop signal logic
- Voltage and Current limiters
- Energy Savings Calculator
- Two independent set of Acceleration/Deceleration ramps
- Skip frequency
- Start source (Local/Remote control function)
- Reference source
- Flying start
- Volts per Hertz control programmable
- Real time clock—RTC time display
- Auto restart on fault to drive or bypass
- Programmable switching frequency
- Multi-Preset speeds
- Fan control
- DC brake

I/O controls

• Terminal To Function (TTF) Programming

The design behind the programming of the digital inputs in the VS3 drive is to use "Terminal To Function" programming, which is composed of multiple functions that get assigned a digital input to that function. The parameters in the drive are set up with specific functions and by defining the digital input and slot in some cases, depending on which options are available. For use of the drives control board inputs, they will be referred to as DigIN:1 through DigIN:8. When additional option cards are used, they will be defined as DigIN:X:IOY:Z. The X indicates the slot that the card is being installed in, which will be either A or B. The IOY determines the type of card it is, which would be IO1 or IO5. The Z indicates which input is being used on that available option card.

• Function To Terminal (FTT) Programming

The design behind the programming of the relay outputs and digital output in the VS3 drive is to use "Function To Terminal" programming. It is composed of a terminal, be it a relay output or a digital output, that is assigned a parameter. Within that parameter, it has different functions that can be set.

The parameters of the Standard Application are explained in Appendix A of this manual, "Description of Parameters."

The explanations are arranged according to the parameter number. For the DI function, we use Terminal programming method to function (TTF), where there is a fixed input that gets programmed to a list of functions. This allows for multiple inputs to be used for different functions. Connecting a certain input with a certain parameter function is done by give a parameter an appropriate value. The value is formed by the location of the input, either being on the standard control board or an external option board and the slot it is located in.

Force open/force close selection

The Force Open Selection would make the selected function always off. Essentially this is a virtual switch that is always open. The Force Close Selection would make the selected function always on. Essentially this is a virtual switch that is always closed. These options are assigned to a function if we want to force a state without using a hardware input.

The standard options are DigIn: Force Open - indication that the parameter function is always going to be open, that being said depending on the logic of the function this could mean the function is always not active or always active. When the selection of a function is DigIn: Force Closed - indication that the parameter function is always going to be closed, that being said again depending on the location of the function this could mean the function is always active or not active. Examples of these options would be ID190 Start Signal 1, when set to "Force Open" and the drive is looking at I/O terminals for control, in this case the drive would never start since this Function is always Open. If this function is set to "Force closed" the drive would always be in a start mode when in that control location.

Example:

If we set Run Enable to Force Closed the drive is always enabled. If we set the same function to Force Open the drive would never be Enabled. If a Digital input is to be used to activate this Run Enable the function should be assigned to a hardware input(See below for DIGIN Selections).

DIGIN selection

This allows Assignment of a hardware digital input to a function, this is set in a format of DigIN:X where X is one of the 8 Digital inputs on the Main control board.

Example:

If we set Run Enable to DigIN:6 the drive will be enabled when digital input 6 (Terminal 8) is closed, and would not be enabled when digital input 6 (Terminal 8) is open.

Option board digIN selection

This allows Assignment of a hardware digital input on an option card to a function, this is set in a format of DigIN: Y:IO1:X where Y is the slot the option card is inserted on the Main control board and X is the Input on the Board and IO1 is the type of option board used.

Example:

If we set Run Enable to DigIN:A:IO5:6 the drive will be enabled when digital input 6 is closed on the IO5 option card which is inserted in Slot A, and would not be enabled when digital input 6 on the option card is open.

Timer channel selection

A Time Channel is a virtual path to link the digital output of a timer function to a digital input function. To utilize this feature a timer or interval would need to be assigned to a time channel 1 through 3, and the input function to be controlled would need to be assigned to the same time channel.

Example:

If we set Run Enable to DigIN:TimeChannel1 the drive will be enabled when the timer assigned to Time Channel 1 is active or High, and would not be enabled when the Time Channel is inactive or Low.

Basic Application Control I/O configuration

- Run 240 Vac and 24 Vdc control wiring in separate conduit
- Communication wire to be shielded

Table 16. I/O connection



External Wiring	Pin	Signal Name	Signal	Default Setting	Description
	1	+10V	Ref. Output Voltage	-	10VDC Supply Source
	2	AI1+ ①	Analog Input 1	0-10V	Voltage Speed Reference (Programmable to 4-20mA)
	3	AI1-	Analog Input 1 Ground	-	Analog Input 1 Common (Ground)
	4	AI2+ ①	Analog Input 2	4-20mA	Current Speed Reference (Programmable to 0-10V)
	5	AI2-	Analog Input 2 Ground	-	Analog Input 2 Common (Ground)
	6	GND	I/O Signal Ground	-	I/O Ground for Reference and Control
	7	DIN5	Digital Input 5	Preset Speed B0	Sets frequency output to Preset Speed 1
	8	DIN6	Digital Input 6	Fire Mode	Enables drive into Fire Mode
	9	DIN7	Digital Input 7 TI+	Bypass Start	Enables drive into Bypass mode waiting for drive start
	10	DIN8	Digital Input 8 TI-	Force Auto	Input forces drive into Auto Control place
	11	CMB	DI5 to DI8 Common	Grounded	Allows source input
	12	GND	I/O Signal Ground	-	I/O Ground for Reference and Control
	13	24Vo	+24VDC Output	-	Control voltage output (100mA Max)
	14	DO1	Digital Output 1	Ready	Shows the drive is ready to run
	15	24Vo	+24VDC Output	-	Control voltage output (100mA Max)
	16	GND	I/O Signal Ground	-	I/O Ground for Reference and Control
	17	A01+	Analog Output 1	Output Frequency	Shows Output frequency to motor 0 - 60Hz (4-20mA)
	18	A02+	Analog Output 2	Motor Current	Shows Motor current of motor 0-FLA (4-20mA)
	19	24Vi	+24VDC Input	-	External control voltage input
	20	DIN1	Digital Input 1	Run Forward	Input starts drive in forward direction (start enable)
	21	DIN2	Digital Input 2	Run Reverse	Input starts drive in reverse direction(start enable)
	22	DIN3	Digital Input 3	External Fault	Input causes drive to fault
	23	DIN4	Digital Input 4	Fault Reset	Input resets active faults
	24	CMA	DI1 to DI4 Common	Grounded	Allows source input
	25	A	RS-485 Signal A/+	-	Fieldbus Communication (Modbus, BACnet)
	26	B	RS-485 Signal B/-	-	Fieldbus Communication (Modbus, BACnet)
	27	R3NO	Relay 3 Normally Open	Fault	Relay output 3 shows VFD is Faulted
	28	R1NC	Relay 1 Normally Closed	Bypass Run	Relay output 1 shows VFD is in a bypass run state
	29	R1CM	Relay 1 Common		
	30	R1NO	Relay 1 Normally Open		
	31	R3CM	Relay 3 Common	Fault	Relay output 3 shows VFD is Faulted
	32	R2NC	Relay 2 Normally Closed	Run	Relay output 2 shows VFD is in a drive run state
	33	R2CM	Relay 2 Common		
	34	R2NO	Relay 2 Normally Open		

Notes: The above wiring demonstrates a SINK configuration. It is important that CMA and CMB are wired to ground (as shown by dashed line). If a SOURCE configuration is desired, wire 24 V to CMA and CMB and close the inputs to ground. When using the +10 V for AI1, it is important to wire AI1—ground (as shown by dashed line). If using +10 V for AI1 or AI2, terminals 3, 5, and 6 need to be jumpered together.
 ① AI1+ and AI2+ Support 10K potentiometer.

Table 17. Drive communication ports

Port	Communication
RJ45 Keypad Port	
Upload/Download Parameters	USB to RJ45
Remote Mount Keypad	Ethernet
Upgrade Drive Firmware	USB to RJ45
RJ45 Ethernet Port	
Upload/Download Parameters	Ethernet
BACnet IP Communications	Ethernet
Modbus TCP Communications	Ethernet
RS-485 Serial Port ①	
Upload/Download Parameters	
Upgrade Drive Firmware	Two-Wire Twisted Pair
Modbus RTU Communications	Two-Wire Twisted Pair
BACnet MS/TP Communications	Two-Wire Twisted Pair

① Shielded wire recommended.

Control I/O configuration

- Run 240 Vac and 24 Vdc control wiring in separate conduit
- Communication wire to be shielded

Basic application—parameters list

On the next pages you will find the lists of parameters within the respective parameter groups. The parameter descriptions are given in Appendix A, “Description of Parameters.” The descriptions are arranged according to the parameter number.

Column explanations:

Code = Location indication on the keypad; shows the operator the present parameter number

Parameter = Name of parameter

Min = Minimum value of parameter

Max = Maximum value of parameter

Unit = Unit of parameter value; given if available

Default = Value preset by factory

ID = ID number of the parameter

Monitor

Table 18. Basic—M1

Code	Parameter	Min.	Max.	Unit	Default	ID	Note
M1.1	Output Frequency			Hz		1	
M1.2	Freq Reference			Hz		24	
M1.3	Motor Speed			rpm		2	
M1.4	Motor Current			A		3	
M1.5	Motor Torque			%		4	
M1.6	Motor Power			%		5	
M1.7	Motor Voltage			V		6	
M1.8	DC-link Voltage			V		7	
M1.9	Unit Temperature			°C		8	
M1.10	Motor Temperature			%		9	
M1.11	Latest Fault Code					28	
M1.12	Instant Motor Power			kW		1686	
M1.13	RTC Battery Status					583	0 = Not Installed 1 = Installed 2 = Change Battery 3 = OverVoltage

Table 19. IO Status—M2

Code	Parameter	Min.	Max.	Unit	Default	ID	Note
M2.1	Analog Input 1			Varies		10	
M2.2	Analog Input 2			Varies		11	
M2.3	Analog Output 1			Varies		25	
M2.4	Analog Output 2			Varies		575	
M2.5	DI1, DI2, DI3					12	
M2.6	DI4, DI5, DI6					13	
M2.7	DI7, DI8					576	
M2.8	DO1,Virtual RO1,Virtual RO2					14	
M2.9	RO1, RO2, RO3					557	

Chapter 5—Basic application

Table 20. Optional Boards — M3

Code	Parameter	Min.	Max.	Unit	Default	ID	Note
M3.1	PT100 Temperature			°C	1000.0	27	

Table 21. Energy Savings — M4

Code	Parameter	Min.	Max.	Unit	Default	ID	Note
M4.1 ©	Energy Savings			Varies	0.000	2120	

Table 22. FB Monitor Menu — M5

Code	Parameter	Min.	Max.	Unit	Default	ID	Note
M5.1	Control Board DIDO Status					2209	Bit 0 = DIN1 Status Bit 1 = DIN2 Status Bit 2 = DIN3 Status Bit 3 = DIN4 Status Bit 4 = DIN5 Status Bit 5 = DIN6 Status Bit 6 = DIN7 Status Bit 7 = DIN8 Status Bit 8 = DO1 Status Bit 9 = RO1 Status Bit 10 = RO2 Status Bit 11 = RO3 Status Bit 12 = SlotA with board Bit 13 = SlotB with board Bit 14 = Virtual RO1 Status Bit 15 = Virtual RO2 Status
M5.2	SlotA DIDO Status					2210	Bit 0 = IO1_DIN1 Status Bit 1 = IO1_DIN2 Status Bit 2 = IO1_DIN3 Status Bit 3 = IO1_DO1 Status Bit 4 = IO1_DO2 Status Bit 5 = IO1_DO3 Status Bit 6 = IO3_RO1 Status Bit 7 = IO3_RO2 Status Bit 8 = IO3_RO3 Status Bit 9 = IO5_AC1 Status Bit 10 = IO5_AC2 Status Bit 11 = IO5_AC3 Status Bit 12 = IO5_AC4 Status Bit 13 = IO5_AC5 Status Bit 14 = IO5_AC6 Status
M5.3	SlotB DIDO Status					2211	Bit 0 = IO1_DI1 Bit 1 = IO1_DI2 Bit 2 = IO1_DI3 Bit 3 = IO1_DO1 Bit 4 = IO1_DO2 Bit 5 = IO1_DO3 Bit 6 = IO3_RO1 Bit 7 = IO3_RO2 Bit 8 = IO3_RO3 Bit 9 = IO5_AC1 Bit 10 = IO5_AC2 Bit 11 = IO5_AC3 Bit 12 = IO5_AC4 Bit 13 = IO5_AC5 Bit 14 = IO5_AC6 Bit 15 = Not Used

Note: © Parameter value will be set to be default when changing macros.

Table 22. FB Monitor Menu — M5 continued

Code	Parameter	Min.	Max.	Unit	Default	ID	Note
M5.4	Application Status Word					29	Bit 0 = MC_Ready Bit 1 = MC_Run Bit 2 = MC_Fault or Fault Trip Bit 3 = FB_Ref_Active Bit 4 = MC_Stopping Bit 5 = MC_Reverse Bit 6 = MC_Warning or AR Bit 7 = MC_ZeroSpeed Bit 8 = IO Control Indicator Bit 9 = Panel Control Indicator Bit 10 = Panel Fieldbus Control Indicator Bit 11 = MC_DC_Brake Bit 12 = RunEnable Bit 13 = Run Bypass Bit 14 = External Brake Control Bit 15 = In Bypass Mode
M5.5	Standard Status Word					2414	Bit 0 = See PAR ID 2415 (default = Ready) Bit 1 = See PAR ID 2416 (default = Run) Bit 2 = See PAR ID 2417 (default = Fault) Bit 3 = See PAR ID 2418 (default = Fault Invert) Bit 4 = See PAR ID 2419 (default = Warning) Bit 5 = See PAR ID 2420 (default = Reversed) Bit 6 = See PAR ID 2421 (default = At Speed) Bit 7 = See PAR ID 2422 (default = Zero Frequency) Bit 8 - 15 = Not Used

Table 23. User Defined Output — M8

Code	Parameter	Min.	Max.	Unit	Default	ID	Note
M8.1	Output			Varies		2445	
M8.2	Reference			Varies		2447	

Table 24. MWH Monitor — M9

Code	Parameter	Min.	Max.	Unit	Default	ID	Note
M9.1	Total MWh Count			Mwh		601	
M9.2	Total Power Day Count					603	
M9.3	Total Power Hr Count					606	
M9.4	Trip MWh Count			Mwh		604	
M9.5	Trip Power Day Count					636	
M9.6	Trip Power Hr Count					637	

Chapter 5—Basic application

Table 25. Multi-Monitoring — M10

Code	Parameter	Min.	Max.	Unit	Default	ID	Note
M10.1	Multi-Monitoring				1,2,3	30	

Parameters

Table 26. Basic Parameters — P1

Code	Parameter	Min.	Max.	Unit	Default	ID	Note
P1.1 ①②	Min Frequency	0.00	See Par ID 102	Hz	0.00	101	
P1.2 ①②	Max Frequency	See Par ID 101	400.00	Hz	Varies	102	
P1.3 ①	Accel Time 1	0.1	3000.0	s	20.0	103	
P1.4 ①	Decel Time 1	0.1	3000.0	s	20.0	104	
P1.5 ①	Motor Nom Current	DriveNomCurrCT*1/10	DriveNomCurrCT*2	A	DriveNomCurrCT	486	
P1.6 ①	Motor Nom Speed	300	20000	rpm	Varies	489	
P1.7 ①	Motor PF	0.30	1.00		0.85	490	
P1.8 ①	Motor Nom Voltage	180	690	V	Varies	487	
P1.9 ①	Motor Nom Frequency	8.00	400.00	Hz	Varies	488	
P1.10 ①②	HOA Source				0	2465	0 = I/O Terminal/Keypad/ Fieldbus 1 = Keypad 2 = IO Terminal 3 = Fieldbus
P1.11 ①	Hand Control Place				0	1695	0 = Keypad 1 = I/O Terminal Start 1 2 = I/O Terminal Start 2 3 = Fieldbus
P1.12 ①②	Hand Reference				6	136	0 = AI1 1 = AI2 2 = Slot A: AI1 3 = Slot B: AI1 6 = Keypad 7 = Fieldbus Ref 9 = Max Frequency 10 = AI1 + AI2 11 = AI1 - AI2 12 = AI2 - AI1 13 = AI1 * AI2 14 = AI1 or AI2 15 = MIN(AI1,AI2) 16 = MAX(AI1,AI2)
P1.13 ①	Auto 1 Control Place				0	135	0 = I/O Terminal Start 1 1 = Fieldbus 2 = I/O Terminal Start 2 3 = Keypad
P1.14 ①②	Auto 1 Reference				1	137	See Par ID 136
P1.15 ①	Auto 2 Control Place				1	138	See Par ID 135
P1.16 ①②	Auto 2 Reference				7	139	See Par ID 136

Note: ① Parameter value can only be changed after the drive has stopped.
 ② Parameter value will be set to be default when changing macros.

Inputs

Table 27. Basic Setting — P2.1

Code	Parameter	Min.	Min.	Unit	Default	ID	Note
P2.1.4 ②	AI Ref Scale Min Value	0.00	See Par ID 145	Hz	0.00	144	
P2.1.5 ②	AI Ref Scale Max Value	See Par ID 144	400.00	Hz	0.00	145	

Table 28. Digital Input — P2.2

Code	Parameter	Min.	Min.	Unit	Default	ID	Note
P2.2.1 ①②	IO Terminal 1 Start Stop Logic				0	143	0 = Forward - Reverse 1 = Start - Reverse 2 = Start - Enable 3 = Start Pulse - Stop Pulse
P2.2.2 ②③	IO Terminal 1 Start Signal 1				2	190	0 = DigIN:NormallyOpen 1 = DigIN:NormallyClose 2 = DigIN: 1 3 = DigIN: 2 4 = DigIN: 3 5 = DigIN: 4 6 = DigIN: 5 7 = DigIN: 6 8 = DigIN: 7 9 = DigIN: 8 10 = DigIN: A: IO1: 1 11 = DigIN: A: IO1: 2 12 = DigIN: A: IO1: 3 13 = DigIN: A: IO5: 1 14 = DigIN: A: IO5: 2 15 = DigIN: A: IO5: 3 16 = DigIN: A: IO5: 4 17 = DigIN: A: IO5: 5 18 = DigIN: A: IO5: 6 19 = DigIN: B: IO1: 1 20 = DigIN: B: IO1: 2 21 = DigIN: B: IO1: 3 22 = DigIN: B: IO5: 1 23 = DigIN: B: IO5: 2 24 = DigIN: B: IO5: 3 25 = DigIN: B: IO5: 4 26 = DigIN: B: IO5: 5 27 = DigIN: B: IO5: 6 28 = Time Channel 1 29 = Time Channel 2 30 = Time Channel 3 31 = RO1 Function 32 = RO2 Function 33 = RO3 Function 34 = Virtual RO1 Function 35 = Virtual RO2 Function
P2.2.3 ②③	IO Terminal 1 Start Signal 2				3	191	See Par ID 190
P2.2.4 ①②	IO Terminal 2 Start Stop Logic				0	2206	See Par ID 143
P2.2.5 ②③	IO Terminal 2 Start Signal 1				2	2207	See Par ID 190
P2.2.6 ②③	IO Terminal 2 Start Signal 2				3	2208	See Par ID 190

Note: ① Parameter value can only be changed after the drive has stopped.

② Parameter value will be set to be default when changing macros.

③ Input function is Level sensed.

④ Input function is edge sensed.

⑤ Input function is edge sensed when using StartP/StopP start logic.

Chapter 5—Basic application

Table 28. Digital Input — P2.2, continued

Code	Parameter	Min.	Min.	Unit	Default	ID	Note
P2.2.7 ①②	Thermistor Input Select				0	881	0 = Digital Input 1 = Thermistor Input
P2.2.8 ②③	Reverse				0	198	See Par ID 190
P2.2.9 ②③	Ext. Fault 1 NO				4	192	See Par ID 190
P2.2.10 ②③	Ext. Fault 1 NC				1	193	See Par ID 190
P2.2.11 ②	Ext. Fault 1 Text				0	2297	0 = External Fault 1 = Vibration Cut out 2 = High Motor temp 3 = Low Pressure 4 = High Pressure 5 = Low Water 6 = Damper Interlock 7 = Run Enable 8 = Freeeze Stat Trip 9 = Smoke Detect 10 = Seal Leakage 11 = Rod Breakage
P2.2.12 ②③	Ext. Fault 2 NO				0	2293	See Par ID 190
P2.2.13 ②③	Ext. Fault 2 NC				1	2294	See Par ID 190
P2.2.14 ②	Ext. Fault 2 Text				1	2298	See Par ID 2297
P2.2.15 ②③	Ext. Fault 3 NO				0	2295	See Par ID 190
P2.2.16 ②③	Ext. Fault 3 NC				1	2296	See Par ID 190
P2.2.17 ②	Ext. Fault 3 Text				2	2299	See Par ID 2297
P2.2.18 ②④	Fault Reset				5	200	See Par ID 190
P2.2.19 ②③	Run Enable				1	194	See Par ID 190
P2.2.20 ②③	Preset Speed B0				6	205	See Par ID 190
P2.2.21 ②③	Preset Speed B1				0	206	See Par ID 190
P2.2.22 ②③	Preset Speed B2				0	207	See Par ID 190
P2.2.23 ②③	Jog Enable				0	199	See Par ID 190
P2.2.24 ②③	Accel/Decel Time Set				0	195	See Par ID 190
P2.2.25 ②③	Accel/Decel Prohibit				0	201	See Par ID 190
P2.2.26 ②④	No Access To Param				0	215	See Par ID 190
P2.2.27 ②③	Auto Control				9	196	See Par ID 190
P2.2.28 ②③	Hand Control				0	197	See Par ID 190
P2.2.29 ②③	Auto 1/2 Select				0	209	See Par ID 190
P2.2.30 ②③	HOA On/Off				1	2395	See Par ID 190
P2.2.32 ②④	Parameter Set1/2 Sel				0	2312	See Par ID 190
P2.2.33 ②③	AI Ref Source Select				0	208	See Par ID 190
P2.2.34 ②③	Bypass Start				8	218	See Par ID 190
P2.2.35 ②③	Bypass Overload				0	1246	See Par ID 190
P2.2.40 ②③	DC Brake Active				0	202	See Par ID 190
P2.2.42 ②③	Fire Mode				7	220	See Par ID 190
P2.2.43 ②③	Fire Mode Ref 1/2 Select				0	221	See Par ID 190
P2.2.44 ②③	Fire Mode Reverse				0	2119	See Par ID 190

- Note:** ① Parameter value can only be changed after the drive has stopped.
 ② Parameter value will be set to be default when changing macros.
 ③ Input function is Level sensed.
 ④ Input function is edge sensed.

Table 29. Preset Speed — P2.3

Code	Parameter	Min.	Max.	Unit	Default	ID	Note
P2.3.1 ②	Preset Speed 1	0.00	See Par ID 102	Hz	5.00	105	
P2.3.2 ②	Preset Speed 2	0.00	See Par ID 102	Hz	10.00	106	
P2.3.3 ②	Preset Speed 3	0.00	See Par ID 102	Hz	15.00	118	
P2.3.4 ②	Preset Speed 4	0.00	See Par ID 102	Hz	20.00	119	
P2.3.5 ②	Preset Speed 5	0.00	See Par ID 102	Hz	25.00	120	
P2.3.6 ②	Preset Speed 6	0.00	See Par ID 102	Hz	30.00	121	
P2.3.7 ②	Preset Speed 7	0.00	See Par ID 102	Hz	35.00	122	
P2.3.8 ②	Jog Reference	See Par ID 101	See Par ID 102	Hz	0.00	117	

Table 30. AI1 Settings — P2.4

Code	Parameter	Min.	Max.	Unit	Default	ID	Note
P2.4.1	AI1 Mode				1	222	0 = 0 - 20 mA 1 = 0 -10 V
P2.4.2 ②	AI1 Signal Range				0	175	0 = 0-100%/0-20mA/0-10V 1 = 20-100%/4-20mA/2-10V 2 = Customized
P2.4.3 ②	AI1 Custom Min	0.00	See Par ID 177	%	0.00	176	
P2.4.4 ②	AI1 Custom Max	See Par ID 176	100.00	%	100.00	177	
P2.4.5 ②	AI1 Filter Time	0.00	10.00	s	0.10	174	
P2.4.6 ②	AI1 Signal Invert				0	181	0 = Not Inverted 1 = Inverted

Table 31. AI2 Settings — P2.5

Code	Parameter	Min.	Max.	Unit	Default	ID	Note
P2.5.1	AI2 Mode				0	223	0 = 0 - 20 mA 1 = 0 -10 V 2 = -10 - +10 V
P2.5.2 ②	AI2 Signal Range				1	183	0 = 0-100%/0-20mA/0-10V/-10-10V 1 = 20-100%/4-20mA/2-10V/-6-10V 2 = Customized
P2.5.3 ②	AI2 Custom Min	0.00	See Par ID 185	%	0.00	184	
P2.5.4 ②	AI2 Custom Max	See Par ID 184	100.00	%	100.00	185	
P2.5.5 ②	AI2 Filter Time	0.00	10.00	s	0.10	182	
P2.5.6 ②	AI2 Signal Invert				0	189	See Par ID 181

Note: ② Parameter value will be set to be default when changing macros.

Outputs

Table 32. Digital Output — P3.1

Code	Parameter	Min.	Min.	Unit	Default	ID	Note
P3.1.1 [Ⓢ]	DO1 Function				1	151	0 = Not Used 1 = Ready 2 = Run 3 = Fault 4 = Fault Invert 5 = Warning 6 = Reversed 7 = At Speed 8 = Zero Frequency 9 = Freq Limit 1 Superv 10 = Freq Limit 2 Superv 13 = OverHeat Fault 14 = OverCurrent Regular 15 = OverVoltage Regular 16 = UnderVoltage Regular 17 = 4mA Ref Fault/Warning 20 = Torq Limit Superv 21 = Ref Limit Superv 22 = Control from I/O 23 = Un-Requested Rotation Direction 24 = Thermistor Fault Output 25 = Fire Mode 26 = In Bypass Mode 27 = Ext Fault/Warning 28 = Auto Control 29 = Jog Speed Select 30 = Motor Therm Protection 31 = FB Digital Input 1 32 = FB Digital Input 2 33 = FB Digital Input 3 34 = FB Digital Input 4 36 = TC1 Status 37 = TC2 Status 38 = TC3 Status 40 = Power Limit Superv 41 = Temp Limit Superv 42 = Analog Input Superv 51 = Motor Current 1 Supv 52 = Motor Current 2 Supv 53 = Second AI Limit Supv 54 = DC Charge Switch Close 55 = Preheat Active 56 = Cold Weather Active 58 = 2th Stage Ramp Frequency Active 59 = STO Fault Output 60 = Run Bypass/Drive 61 = Bypass Overload 62 = Bypass Run

Note: [Ⓢ] Parameter value will be set to be default when changing macros.

Table 32. Digital Output — P3.1 continued

Code	Parameter	Min.	Max.	Unit	Default	ID	Note
P3.1.2 [Ⓢ]	RO1 Function				62	152	See Par ID 151
P3.1.3 [Ⓢ]	RO1 On Delay	0.0	320.0	s	0.0	2112	
P3.1.4 [Ⓢ]	RO1 Off Delay	0.0	320.0	s	0.0	2113	
P3.1.5 [Ⓢ]	RO2 Function				2	153	See Par ID 151
P3.1.6 [Ⓢ]	RO2 On Delay	0.0	320.0	s	0.0	2114	
P3.1.7 [Ⓢ]	RO2 Off Delay	0.0	320.0	s	0.0	2115	
P3.1.8 [Ⓢ]	RO3 Function				3	538	See Par ID 151
P3.1.9 [Ⓢ]	RO3 On Delay	0.0	320.0	s	0.0	2116	
P3.1.10 [Ⓢ]	RO3 Off Delay	0.0	320.0	s	0.0	2117	
P3.1.11 [Ⓢ]	RO3 Reverse				0	2118	0 = No 1 = Yes
P3.1.12 [Ⓢ]	Virtual RO1 Function				0	2463	See Par ID 151
P3.1.13 [Ⓢ]	Virtual RO2 Function				0	2464	See Par ID 151

Table 33. Supervisions — P3.2

Code	Parameter	Min.	Max.	Unit	Default	ID	Note
P3.2.1 [Ⓢ]	Freq Limit 1 Supv				0	154	0 = No Limit 1 = Low Limit Superv 2 = High Limit Superv
P3.2.2 [Ⓢ]	Freq Limit 1 Supv Val	0.00	See Par ID 102	Hz	0.00	155	
P3.2.3 [Ⓢ]	Freq Limit 1 Supv Hyst	0.10	1.00	Hz	0.10	2200	
P3.2.4 [Ⓢ]	Freq Limit 2 Supv				0	157	See Par ID 154
P3.2.5 [Ⓢ]	Freq Limit 2 Supv Val	0.00	See Par ID 102	Hz	0.00	158	
P3.2.6 [Ⓢ]	Freq Limit 2 Supv Hyst	0.10	1.00	Hz	0.10	2201	
P3.2.7 [Ⓢ]	Torque Limit Supv				0	159	See Par ID 154
P3.2.8 [Ⓢ]	Torque Limit Supv Val	-1000.0	1000.0	%	100.0	160	
P3.2.9 [Ⓢ]	Torque Limit Supv Hyst	1.0	5.0	%	1.0	2202	
P3.2.10 [Ⓢ]	Ref Limit Supv				0	161	See Par ID 154
P3.2.11 [Ⓢ]	Ref Limit Supv Val	0.00	See Par ID 102	Hz	0.00	162	
P3.2.12 [Ⓢ]	Ref Limit Supv Hyst	0.10	1.00	Hz	0.10	2203	
P3.2.13 [Ⓢ]	Temp Limit Supv				0	165	See Par ID 154
P3.2.14 [Ⓢ]	Temp Limit Supv Val	-10.0	75.0	°C	40.0	166	
P3.2.15 [Ⓢ]	Temp Limit Supv Hyst	1.0	10.0	°C	1.0	2204	
P3.2.16 [Ⓢ]	Power Limit Supv				0	167	See Par ID 154
P3.2.17 [Ⓢ]	Power Limit Supv Val	-200.0	200.0	%	0.0	168	
P3.2.18 [Ⓢ]	Power Limit Supv Hyst	0.1	10.0	%	0.1	2205	
P3.2.19 [Ⓢ]	AI Supv Select				0	170	0 = AI1 1 = AI2
P3.2.20 [Ⓢ]	AI Limit Supv				0	171	See Par ID 154
P3.2.21 [Ⓢ]	AI Limit Supv Val	0.00	100.00	%	0.00	172	
P3.2.22 [Ⓢ]	AI Supv Hyst	1.00	10.00	%	1.00	2198	
P3.2.23 [Ⓢ]	Motor Current 1 Supv				0	2189	See Par ID 154
P3.2.24 [Ⓢ]	Motor Current 1 Supv Value	0.0	DriveNomCurrCT*2	A	DriveNomCurrCT	2190	
P3.2.25 [Ⓢ]	Motor Current 1 Supv Hyst	0.1	1.0	A	0.1	2196	
P3.2.26 [Ⓢ]	Motor Current 2 Supv				0	2191	See Par ID 154
P3.2.27 [Ⓢ]	Motor Current 2 Supv Value	0.0	DriveNomCurrCT*2	A	DriveNomCurrCT	2192	
P3.2.28 [Ⓢ]	Motor Current 2 Supv Hyst	0.1	1.0	A	0.1	2197	

Note: [Ⓢ] Parameter value will be set to be default when changing macros.

Chapter 5—Basic application

Table 33. Supervisions — P3.2 continued

Code	Parameter	Min.	Max.	Unit	Default	ID	Note
P3.2.29 [Ⓢ]	Second AI Supv Select				0	2193	See Par ID 170
P3.2.30 [Ⓢ]	Second AI Limit Supv				0	2194	See Par ID 154
P3.2.31 [Ⓢ]	Second AI Limit Supv Val	0.00	100.00	%	0.00	2195	
P3.2.32 [Ⓢ]	Second AI Supv Hyst	1.00	10.00	%	1.00	2199	

Table 34. Analog Output 1 — P3.3

Code	Parameter	Min.	Max.	Unit	Default	ID	Note
P3.3.1 [Ⓢ]	AO1 Mode				0	227	See Par ID 222
P3.3.2 [Ⓢ]	AO1 Function				1	146	0 = Not Used 1 = Output Frequency 2 = Freq Reference 3 = Motor Speed (0-Nom) 4 = Motor Current (0-Nom) 5 = Motor Torque (0-Nom) 6 = Motor Power (0-Nom) 7 = Motor Voltage (0-Nom) 8 = DC-Bus Voltage 19 = AI1 20 = AI2 21 = Output Freq (-2+2N) 22 = Motor Torque (-2+2N) 23 = Motor Power (-2+2N) 24 = PT100 Temperature 33 = SlotA PT100 Temp Channel 1 34 = SlotA PT100 Temp Channel 2 35 = SlotA PT100 Temp Channel 3 36 = SlotB PT100 Temp Channel 1 37 = SlotB PT100 Temp Channel 2 38 = SlotB PT100 Temp Channel 3 39 = User Defined Output 40 = Motor Current (-2+2N)
P3.3.3 [Ⓢ]	AO1 Minimum				1	149	0 = 0V / 0 mA 1 = 2V / 4 mA
P3.3.4 [Ⓢ]	AO1 Filter Time	0.00	10.00	s	1.00	147	
P3.3.5 [Ⓢ]	AO1 Scale	10	1000	%	100	150	
P3.3.6 [Ⓢ]	AO1 Inversion				0	148	See Par ID 181
P3.3.7 [Ⓢ]	AO1 Offset	-100.00	100.00	%	0.00	173	

Table 35. Analog Output 2 — P3.4

Code	Parameter	Min.	Max.	Unit	Default	ID	Note
P3.4.1 [Ⓢ]	AO2 Mode				0	228	See Par ID 222
P3.4.2 [Ⓢ]	AO2 Function				4	229	See Par ID 146
P3.4.3 [Ⓢ]	AO2 Minimum				1	232	See Par ID 149
P3.4.4 [Ⓢ]	AO2 Filter Time	0.00	10.00	s	1.00	230	
P3.4.5 [Ⓢ]	AO2 Scale	10	1000	%	100	233	
P3.4.6 [Ⓢ]	AO2 Inversion				0	231	See Par ID 181
P3.4.7 [Ⓢ]	AO2 Offset	-100.00	100.00	%	0.00	234	

Note: [Ⓢ] Parameter value will be set to be default when changing macros.

Drive Control

Table 36. Basic Setting — P4.1

Code	Parameter	Min.	Max.	Unit	Default	ID	Note
P4.1.1 ②	Keypad Reference	See Par ID 101	See Par ID 102	Hz	0.00	141	
P4.1.2 ②	Keypad Direction				0	116	0 = Forward 1 = Reverse
P4.1.3 ②	Keypad Stop				1	114	0 = Enabled-Keypad Operation 1 = Always Enabled
P4.1.4 ②	Hand Key Enable				0	1724	0 = Enabled 1 = Disabled
P4.1.5 ①	Reverse Enable				1	1679	0 = Disabled 1 = Enabled
P4.1.6	Change PhaseSequence Motor				0	2515	0 = Change Disable 1 = Change Enable
P4.1.7 ②	Power Up HOA Select				0	1685	0 = Hold Last 1 = Hand Control 2 = Auto control 3 = Off
P4.1.9 ②	Run Delay Time	0	32500	s	0	2423	
P4.1.10 ②	Start Mode				0	252	0 = Ramp 1 = Flying Start
P4.1.11 ②	Stop Mode				0	253	0 = Coasting 1 = Ramp
P4.1.12 ②	Ramp 1 Shape	0.0	10.0	s	0.0	247	
P4.1.13 ②	Ramp 2 Shape	0.0	10.0	s	0.0	248	
P4.1.14 ②	Accel Time 2	0.1	3000.0	s	10.0	249	
P4.1.15 ②	Decel Time 2	0.1	3000.0	s	10.0	250	
P4.1.16 ②	Power Loss Function				0	267	See Par ID 1679
P4.1.17 ②	Power Loss Time	0.3	5.0	s	2.0	268	
P4.1.18 ①②	2nd Stage Ramp Frequency	See Par ID 101	See Par ID 102	Hz	30.00	2444	

Table 37. Brake — P4.2

Code	Parameter	Min.	Max.	Unit	Default	ID	Note
P4.2.1 ①②	DC-Brake Current	DriveNomCurrCT*15/100	DriveNomCurrCT*15/10	A	DriveNomCurrCT*1/2	254	
P4.2.2 ①②	Start DC-Brake Time	0.00	600.00	s	0.00	263	
P4.2.3 ①②	Stop DC-Brake Frequency	0.10	10.00	Hz	1.50	262	
P4.2.4 ①②	Stop DC-Brake Time	0.00	600.00	s	0.00	255	
P4.2.5 ①②	Brake Chopper Define				0	251	0 = Disabled 1 = B(Run) T(Rdy) 2 = External 3 = B(Rdy) T(Rdy) 4 = B(Run) T(No)
P4.2.6 ①②	Flux Brake						0 = Off 1 = On
P4.2.7 ①②	Flux Brake Current	ActiveMotorNomCurr*1/10	See Par ID 107	A	ActiveMotorNomCurr*1/2	265	

Table 38. Skip Frequency — P4.3

Code	Parameter	Min.	Max.	Unit	Default	ID	Note
P4.3.1 ②	Skip Range Ramp Factor	0.1	10.0		1.0	264	
P4.3.2 ②	Skip F1 Low Limit	0.00	See Par ID 257	Hz	0.00	256	
P4.3.3 ②	Skip F1 High Limit	See Par ID 256	400.00	Hz	0.00	257	
P4.3.4 ②	Skip F2 Low Limit	0.00	See Par ID 259	Hz	0.00	258	
P4.3.5 ②	Skip F2 High Limit	See Par ID 258	400.00	Hz	0.00	259	
P4.3.6 ②	Skip F3 Low Limit	0.00	See Par ID 261	Hz	0.00	260	
P4.3.7 ②	Skip F3 High Limit	See Par ID 260	400.00	Hz	0.00	261	

Notes: ① Parameter value can only be changed after the drive has stopped.

② Parameter value will be set to be default when changing macros.

Table 39. Analog Output 2 — P3.4

Code	Parameter	Min.	Max.	Unit	Default	ID	Note
P4.4.1 ②	Currency				0	2122	0 = \$ 1 = £ 2 = € 3 = ¥ 4 = Rs 5 = R\$ 6 = Fr 7 = kr
P4.4.2 ②	Energy Cost			Varies	0.00	2123	
P4.4.3 ②	Data Type				0	2124	0 = Cumulative 1 = Daily Avg 2 = Weekly Avg 3 = Monthly Avg 4 = Yearly Avg
P4.4.4	Energy Savings Reset					2125	0 = Not Reset 1 = Reset

Motor Control

Table 40. Basic Setting — P5.1

Code	Parameter	Min.	Max.	Unit	Default	ID	Note
P5.1.1 ①②	Motor Control Mode				0	287	0 = Freq Control 1 = Speed Control
P5.1.2 ①	Current Limit	DriveNomCurrCT*1/10	DriveNomCurrCT*2	A	DriveNomCurrCT*2	107	
P5.1.3 ①②	V/Hz Optimization				0	109	See Par ID 1679
P5.1.4 ①②	V/Hz Ratio				3	108	0 = Linear 1 = Squared 2 = Programmable 3 = Linear + Flux Optimization
P5.1.5 ①②	Field Weakening Point	8.00	400.00	Hz	Varies	289	
P5.1.6 ①②	Voltage at FWP	10.00	200.00	%	100.00	290	
P5.1.7 ①②	V/Hz Mid Frequency	0.00	See Par ID 289	Hz	Varies	291	
P5.1.8 ①②	V/Hz Mid Voltage	0.00	100.00	%	100.00	292	
P5.1.9 ①②	Zero Frequency Voltage	0.00	40.00	%	0.00	293	
P5.1.10 ②	Switching Frequency	MinSwitchFreq	MaxSwitchFreq	kHz	DefaultSwitchFreqCT	288	
P5.1.11 ②	Sine Filter Enable				0	1665	See Par ID 1679
P5.1.12 ①②	OverVoltage Control				1	294	See Par ID 1679

Protections

Table 41. Motor — P6.1

Code	Parameter	Min.	Max.	Unit	Default	ID	Note
P6.1.1 ①②	Output Phase Fault				2	308	0 = No Action 1 = Warning 2 = Fault 3 = Fault, Coast
P6.1.2 ①②	Ground Fault				2	309	See Par ID 308
P6.1.3 ②	Ground Fault Limit	0	30	%	15	2158	
P6.1.4 ①②	Motor Thermal Protection				2	310	See Par ID 308
P6.1.5 ②	Motor Thermal FO Current	0.0	150.0	%	40.0	311	

Notes: ① Parameter value can only be changed after the drive has stopped.
② Parameter value will be set to be default when changing macros.

Table 41. Motor — P6.1, continued

Code	Parameter	Min.	Max.	Unit	Default	ID	Note
P6.1.6 ②	Motor Thermal Time	1	200	min	12	312	
P6.1.7 ①②	Stall Protection				0	313	See Par ID 308
P6.1.8 ②	Stall Current Limit	0.1	ActiveMotorNomCurr*2	A	ActiveMotorNomCurr*13/10		
P6.1.9 ②	Stall Time Limit	1.0	120.0	s	15.0		
P6.1.10 ②	Stall Frequency Limit	1.00	See Par ID 102	Hz	25.00		
P6.1.11 ①②	Underload Protection				0		
P6.1.12 ②	Underload Fnom Torque	10.0	150.0	%	50.0		
P6.1.13 ②	Underload FO Torque	5.0	150.0	%	10.0		
P6.1.14 ②	Underload Time Limit	2.00	600.00	s	20.00		
P6.1.15 ①②	Thermistor Fault Response				2		
P6.1.16 ①②	PT100 Fault Response				2		
P6.1.17 ②	Preheat Mode				0		
P6.1.18 ②	Preheat Control Source				31	2160	0 = DigIN:NormallyOpen 1 = DigIN:NormallyClose 2 = DigIN: 1 3 = DigIN: 2 4 = DigIN: 3 5 = DigIN: 4 6 = DigIN: 5 7 = DigIN: 6 8 = DigIN: 7 9 = DigIN: 8 10 = DigIN: A: IO1: 1 11 = DigIN: A: IO1: 2 12 = DigIN: A: IO1: 3 13 = DigIN: A: IO5: 1 14 = DigIN: A: IO5: 2 15 = DigIN: A: IO5: 3 16 = DigIN: A: IO5: 4 17 = DigIN: A: IO5: 5 18 = DigIN: A: IO5: 6 19 = DigIN: B: IO1: 1 20 = DigIN: B: IO1: 2 21 = DigIN: B: IO1: 3 22 = DigIN: B: IO5: 1 23 = DigIN: B: IO5: 2 24 = DigIN: B: IO5: 3 25 = DigIN: B: IO5: 4 26 = DigIN: B: IO5: 5 27 = DigIN: B: IO5: 6 28 = Time Channel 1 29 = Time Channel 2 30 = Time Channel 3 31 = Drive Temperature 32 = SlotA PT100 Temp Channel 1 33 = SlotA PT100 Temp Channel 2 34 = SlotA PT100 Temp Channel 3 35 = SlotA Max PT100 Temp 36 = SlotB PT100 Temp Channel 1 37 = SlotB PT100 Temp Channel 2 38 = SlotB PT100 Temp Channel 3 39 = SlotB Max PT100 Temp 40 = SlotA and SlotB Max PT100 Temp

Notes: ① Parameter value can only be changed after the drive has stopped.

② Parameter value will be set to be default when changing macros.

Chapter 5—Basic application

Table 41. Motor — P6.1, continued

Code	Parameter	Min.	Max.	Unit	Default	ID	Note
P6.1.19 ②	Preheat Enter Temp	0.0	19.9	°C	10.0	2161	
P6.1.20 ②	Preheat Quit Temp	20.0	40.0	°C	20.0	2162	
P6.1.21 ②	Preheat Output Volt	0.0	20.0	%	2.0	2163	

Table 42. Drive — P6.2

Code	Parameter	Min.	Max.	Unit	Default	ID	Note
P6.2.1 ②	Line Start Lockout				2	750	0 = Disabled, No Change 1 = Enable, No Change 2 = Disabled, Changed 3 = Enable, Changed
P6.2.2 ②	Fault Reset Start				0	2483	0 = Start/Stop After Fault Reset 1 = Restart After Fault Reset
P6.2.3 ①②	4mA Input Fault				0	306	0 = No Action 1 = Warning 2 = Warning: Previous Freq 3 = Warning: Preset Freq 4 = Fault 5 = Fault, Coast
P6.2.4 ①②	4mA Fault Frequency	0.00	See Par ID 102	Hz	0.00	331	
P6.2.5 ①②	External Fault				2	307	See Par ID 308
P6.2.6 ①②	Input Phase Fault				2	332	See Par ID 308
P6.2.7 ①②	Uvolt Fault Response				2	330	See Par ID 308
P6.2.8 ①②	Unit Under Temp Prot				2	1564	See Par ID 308
P6.2.9 ①②	RTC Fault				1	955	See Par ID 308
P6.2.10 ①②	Replace Battery Fault Response				1	1256	See Par ID 308
P6.2.11 ①②	Replace Fan Fault Response				1	1257	See Par ID 308
P6.2.12 ②	Cold Weather Mode				0	2126	See Par ID 1679
P6.2.13 ②	Cold Weather Volt. Level	0.0	20.0	%	2.0	2127	
P6.2.14 ②	Cold Weather Time Out	0	10	min	3	2128	
P6.2.15	Cold Weather Password					2129	
P6.2.16	Under Temp Fault Override					2130	See Par ID 2118
P6.2.17 ②	STO Fault Response				2	2427	0 = No Action 1 = Warning 2 = Fault

Table 43. Communication — P6.3

Code	Parameter	Min.	Max.	Unit	Default	ID	Note
P6.3.1 ①②	Fieldbus Fault Response				2	334	0 = No Action 1 = Warning 2 = Fault 3 = Fault, Coast 4 = Warning, Coast
P6.3.2 ①②	OPTCard Fault Response				2	335	See Par ID 308
P6.3.3 ①②	IP Address Confliction Resp				1	1678	See Par ID 308
P6.3.4 ①②	Keypad Comm Fault Response				2	2157	See Par ID 308

Notes: ① Parameter value can only be changed after the drive has stopped.
② Parameter value will be set to be default when changing macros.

Table 44. Auto Restart — P6.4

Code	Parameter	Min.	Max.	Unit	Default	ID	Note
P6.4.1 ②	AR Wait Time	1.00	300.00	s	1.00	321	
P6.4.2 ②	AR Trail Time	0.00	600.00	s	30.00	322	
P6.4.3 ②	AR Start Function				0	323	0 = Flying Start 1 = Ramp
P6.4.4 ②	Undervoltage Attempts	0	10		1	324	
P6.4.5 ②	OverVoltage Attempts	0	10		1	325	
P6.4.6 ②	OverCurrent Attempts	0	3		1	326	
P6.4.7 ②	4mA Fault Attempts	0	10		1	327	
P6.4.8 ②	Motor Temp Fault Attempts	0	10		1	329	
P6.4.9 ②	External Fault Attempts	0	10		0	328	
P6.4.10 ②	Underload Attempts	0	10		1	336	

Table 45. Fire Mode — P9

Code	Parameter	Min.	Max.	Unit	Default	ID	Note
P9.1 ①②	Fire Mode Function				0	535	0 = Closing Contact 1 = Opening Contact
P9.2 ①②	Fire Mode Ref Select Function				0	536	0 = Fire Mode Min Frequency 1 = Fire Mode Ref 2 = Fieldbus Ref 3 = AI1 4 = AI2 5 = AI1 + AI2
P9.3 ②	Fire Mode Min Frequency	See Par ID 101	See Par ID 102	Hz	15.00	537	
P9.4 ②	Fire Mode Freq Ref 1	0.0	100.0	%	75.0	565	
P9.5 ②	Fire Mode Freq Ref 2	0.0	100.0	%	100.0	564	
P9.6	Fire Mode Test Enable					2443	See Par ID 1679

Bypass

Table 46. Basic Setting — P10.1

Code	Parameter	Min.	Max.	Unit	Default	ID	Note
P10.1.1 ①②	Bypass Enable				1	1418	See Par ID 1679
P10.1.2 ①②	Bypass Start Delay	1	32765	s	1	544	
P10.1.3 ①②	Auto Bypass				1	542	See Par ID 1679
P10.1.4 ①②	Auto Bypass Delay	0	32765	s	10	543	
P10.1.5 ①②	OverCurrent Bypass Enable				1	547	See Par ID 1679
P10.1.6 ①②	IGBT Fault Bypass Enable				1	546	See Par ID 1679
P10.1.7 ①②	4mA Fault Bypass Enable				1	548	See Par ID 1679
P10.1.8 ①②	UnderVoltage Bypass Enable				1	545	See Par ID 1679
P10.1.9 ①②	OverVoltage Bypass Enable				1	549	See Par ID 1679
P10.1.10 ①②	Motor OverTemp Bypass Enable				1	1698	See Par ID 1679
P10.1.11 ①②	UnderLoad Bypass Enable				1	1699	See Par ID 1679
P10.1.12 ①②	External Bypass Enable				1	1700	See Par ID 1679
P10.1.13 ①②	Charge Switch Fault Bypass Enable				1	1701	See Par ID 1679
P10.1.14 ①②	Saturation Trip Fault Bypass Enable				1	1702	See Par ID 1679
P10.1.15 ①②	Under Temp Fault Bypass Enable				1	1703	See Par ID 1679
P10.1.16 ①②	EEPROM Fault Bypass Enable				1	1704	See Par ID 1679
P10.1.17 ①②	FRAM Fault Bypass Enable				1	1705	See Par ID 1679
P10.1.18 ①②	Watchdog Fault Bypass Enable				1	1706	See Par ID 1679

Notes: ① Parameter value can only be changed after the drive has stopped.

② Parameter value will be set to be default when changing macros.

Table 46. Basic Setting — P10.1, continued

Code	Parameter	Min.	Max.	Unit	Default	ID	Note
P10.1.19 ①②	Fan Cooling Fault Bypass Enable				1	1707	See Par ID 1679
P10.1.20 ①②	Keypad Com Fault Bypass Enable				1	1708	See Par ID 1679
P10.1.21 ①②	Option Card Fault Bypass Enable				1	1709	See Par ID 1679
P10.1.22 ①②	RTC Clock Fault Bypass Enable				1	1710	See Par ID 1679
P10.1.23 ①②	Ctrl Board OverTemp Fault Bypass Enable				1	1711	See Par ID 1679
P10.1.24 ①②	Speed Search Start Fault Bypass Enable				1	1712	See Par ID 1679
P10.1.25 ①②	Fieldbus Fault Bypass Enable				1	1713	See Par ID 1679

Communication

Table 47. FB Process Data Input Sel — P12.1

Code	Parameter	Min.	Max.	Unit	Default	ID	Note
P12.1.1 ②	FB Process Data Input 1 Sel	0	2560		0	2533	
P12.1.2 ②	FB Process Data Input 2 Sel	0	2560		2542	2534	
P12.1.3 ②	FB Process Data Input 3 Sel	0	2560		2550	2535	
P12.1.4 ②	FB Process Data Input 4 Sel	0	2560		103	2536	
P12.1.5 ②	FB Process Data Input 5 Sel	0	2560		104	2537	
P12.1.6 ②	FB Process Data Input 6 Sel	0	2560		107	2538	
P12.1.7 ②	FB Process Data Input 7 Sel	0	2560		0	2539	
P12.1.8 ②	FB Process Data Input 8 Sel	0	2560		0	2540	

Table 48. FB Process Data Output Sel — P12.2

Code	Parameter	Min.	Max.	Unit	Default	ID	Note
P12.2.1 ②	FB Process Data Output 1 Sel				1	1556	
P12.2.2 ②	FB Process Data Output 2 Sel				2	1557	
P12.2.3 ②	FB Process Data Output 3 Sel				3	1558	
P12.2.4 ②	FB Process Data Output 4 Sel				4	1559	
P12.2.5 ②	FB Process Data Output 5 Sel				5	1560	
P12.2.6 ②	FB Process Data Output 6 Sel				6	1561	
P12.2.7 ②	FB Process Data Output 7 Sel				7	1562	
P12.2.8 ②	FB Process Data Output 8 Sel				28	1563	
P12.2.9 ②	Standard Status Word Bit0 Function Select				1	2415	0 = Not Used 1 = Ready 2 = Run 3 = Fault 4 = Fault Invert 5 = Warning 6 = Reversed 7 = At Speed 8 = Zero Frequency 9 = Freq Limit 1 Superv 10 = Freq Limit 2 Superv 13 = OverHeat Fault 14 = OverCurrent Regular 15 = OverVoltage Regular 16 = UnderVoltage Regular 17 = 4mA Ref Fault/Warning 20 = Torq Limit Superv 21 = Ref Limit Superv 22 = Control from I/O 23 = Un-Requested Rotation Direction 24 = Thermistor Fault Output 25 = Fire Mode 26 = In Bypass Mode

Notes: ① Parameter value can only be changed after the drive has stopped.
 ② Parameter value will be set to be default when changing macros.

Table 48. FB Process Data Output Sel -- P12.2, continued

Code	Parameter	Min.	Max.	Unit	Default	ID	Note
P12.2.9 ②	Standard Status Word Bit0 Function Select				1	2415	27 = Ext Fault/Warning 28 = Auto Control 29 = Jog Speed Select 30 = Motor Therm Protection 31 = FB Digital Input 1 32 = FB Digital Input 2 33 = FB Digital Input 3 34 = FB Digital Input 4 36 = TC1 Status 37 = TC2 Status 38 = TC3 Status 40 = Power Limit Superv 41 = Temp Limit Superv 42 = Analog Input Superv 51 = Motor Current 1 Supv 52 = Motor Current 2 Supv 53 = Second AI Limit Supv 54 = DC Charge Switch Close 55 = Preheat Active 56 = Cold Weather Active 58 = 2th Stage Ramp Frequency Active 59 = STO Fault Output 60 = Run Bypass/Drive 61 = Bypass Overload 62 = Bypass Run
P12.2.10 ②	Standard Status Word Bit1 Function Select				2	2416	See Par ID 2415
P12.2.11 ②	Standard Status Word Bit2 Function Select				3	2417	See Par ID 2415
P12.2.12 ②	Standard Status Word Bit3 Function Select				4	2418	See Par ID 2415
P12.2.13 ②	Standard Status Word Bit4 Function Select				5	2419	See Par ID 2415
P12.2.14 ②	Standard Status Word Bit5 Function Select				6	2420	See Par ID 2415
P12.2.15 ②	Standard Status Word Bit6 Function Select				7	2421	See Par ID 2415
P12.2.16 ②	Standard Status Word Bit7 Function Select				8	2422	See Par ID 2415

RS485 Bus

Table 49. Basic Setting — P12.3.1

Code	Parameter	Min.	Max.	Unit	Default	ID	Note
P12.3.1.1 ①	RS485 Comm Set				0	586	0 = Modbus RTU 1 = BACnet MS/TP 2 = SA Bus

Table 50. Modbus RTU — P12.3.2

Code	Parameter	Min.	Max.	Unit	Default	ID	Note
P12.3.2.1 ①	Slave Address	1	247		1	587	
P12.3.2.2 ①	Baud Rate				1	584	0 = 9600 1 = 19200 2 = 38400 3 = 57600 4 = 115200
P12.3.2.3 ①	Parity Type				2	585	0 = None 1 = Odd 2 = Even
P12.3.2.4	Modbus RTU Protocol Status					588	0 = Initial 1 = Stopped 2 = Operational 3 = Faulted
P12.3.2.5	Comm Timeout Modbus RTU	0	60000	ms	10000	593	
P12.3.2.6	Modbus RTU Fault Response					2516	0 = in Fieldbus Control 1 = in all Control

Notes: ① Parameter value can only be changed after the drive has stopped.

② Parameter value will be set to be default when changing macros.

Chapter 5—Basic application

Table 51. BACnet MS/TP — P12.3.3

Code	Parameter	Min.	Max.	Unit	Default	ID	Note
P12.3.3.1 ①	MSTP Baud Rate				2	594	0 = 9600 1 = 19200 2 = 38400 3 = 76800 4 = 115200
P12.3.3.2 ①	MSTP Device Address	0	127		1	595	
P12.3.3.3 ①	MSTP Instance Number	0	4194302		Varies	596	
P12.3.3.4	MSTP Comm Timeout	0	60000	ms	10000	598	
P12.3.3.5	MSTP Protocol Status					599	0 = Stopped 1 = Operational 2 = Faulted
P12.3.3.6	MSTP Fault Code					600	0 = None 1 = Sole Master
P12.3.3.7 ①	MSTP Fault Response				0	2526	See Par ID 2516
P12.3.3.8 ①	MSTP Max Master				127	1537	

Table 52. SA Bus — P12.3.4

Code	Parameter	Min.	Max.	Unit	Default	ID	Note
P12.3.4.1 ①②	SA Bus Baud Rate				2	1727	See Par ID 584
P12.3.4.2 ①②	SA Bus Device Address	204	254		204	1726	
P12.3.4.3 ①②	SA Bus Instance Number	0	4194302		0	1728	
P12.3.4.4 ①	SA Bus Comm Timeout	0	60000		10000	1730	
P12.3.4.5	SA Bus Protocol Status					1731	See Par ID 599
P12.3.4.6 ①	SA Bus Fault Response				0	1732	See Par ID 2516

EtherNet Bus

Table 53. Basic Setting — P12.4.1

Code	Parameter	Min.	Max.	Unit	Default	ID	Note
P12.4.1.1 ①	IP Address Mode				1	1500	0 = Static IP 1 = DHCP with AutoIP
P12.4.1.2	Active IP Address					1507	
P12.4.1.3	Active Subnet Mask					1509	
P12.4.1.4	Active Default Gateway					1511	
P12.4.1.5	MAC Address					1513	
P12.4.1.6 ①	Static IP Address				192.168.1.254	1501	
P12.4.1.7 ②	Static Subnet Mask				255.255.255.0	1503	
P12.4.1.8 ①	Static Default Gateway				192.168.1.1	1505	
P12.4.1.9 ①	Enable BACnetIP				0	1725	See Par ID 1679

Table 54. Modbus TCP — P12.4.2

Code	Parameter	Min.	Max.	Unit	Default	ID	Note
P12.4.2.1	Connection Limit				5	609	
P12.4.2.2	Modbus TCP Unit ID				1	610	
P12.4.2.3	Comm Timeout Modbus TCP	0	60000	ms	10000	611	
P12.4.2.4	Modbus TCP Protocol Status					612	See Par ID 611
P12.4.2.5	Modbus TCP Fault Response				0	2517	See Par ID 2516

Notes: ① Parameter value can only be changed after the drive has stopped.
② Parameter value will be set to be default when changing macros.

Table 55. BACnet IP — P12.4.3

Code	Parameter	Min.	Max.	Unit	Default	ID	Note
P12.4.3.1 ①②	BACnet IP UDP port number				47808	1733	47808 = BAC0 47809 = BAC1 47810 = BAC2 47811 = BAC3 47812 = BAC4 47813 = BAC5 47814 = BAC6 47815 = BAC7 47816 = BAC8 47817 = BAC9 47818 = BACA 47819 = BACB 47820 = BACC 47821 = BACD 47822 = BACE 47823 = BACF
P12.4.3.2 ②	BACnet IP Foreign Device				0	1734	See Par ID 1679
P12.4.3.3 ②	BACnet IP BBMD IP				0.0.0.0	1735	
P12.4.3.4 ②	BACnet IP BBMD Port				47808	1737	See Par ID 1733
P12.4.3.5 ②	BACnet IP Registration Interval	0	65535		10	1738	
P12.4.3.6 ②	BACnet IP Comm Timeout	0	60000		0	1739	
P12.4.3.7	BACnet IP Protocol Status					1740	See Par ID 599
P12.4.3.8 ②	BACnet IP Fault Behavior				0	1741	See Par ID 2516
P12.4.3.9 ②	BACnetIP Instance Number	0	4194302		Varies	1742	

System

Table 56. Basic Setting — P13.1

Code	Parameter	Min.	Max.	Unit	Default	ID	Note
P13.1.1	Language				0	340	0 = English 1 = 中文 2 = Deutsch
P13.1.2 ①	Application					142	0 = Basic 1 = PID 2 = Advanced
P13.1.3 ①	Parameter Sets					619	0 = No 1 = Reload Defaults 2 = Reload Set 1 3 = Reload Set 2 4 = Store Set 1 5 = Store Set 2 6 = Reset 7 = Reload Defaults VM
P13.1.4	Up To Keypad					620	See Par ID 2118
P13.1.5 ①	Down From Keypad					621	0 = No 1 = All Parameters 2 = All, No Motor 3 = App Parameters
P13.1.6	Parameter Comparison					623	0 = No 1 = Compare with Keypad 2 = Compare with Default 3 = Compare with Set 1 4 = Compare with Set 2
P13.1.7	Password	0	9999		0	624	
P13.1.8	Parameter Lock				0	625	0 = Change Enable 1 = Change Disable
P13.1.9	Multimonitor Set				0	627	See Par ID 625

Notes: ① Parameter value can only be changed after the drive has stopped.

② Parameter value will be set to be default when changing macros.

Chapter 5—Basic application

Table 56. Basic Setting — P13.1, continued

Code	Parameter	Min.	Max.	Unit	Default	ID	Note
P13.1.10	Default Page				0	628	0 = None 1 = Main Menu 2 = Multi-Monitor 3 = Favorite Menu 4 = Keypad Reference
P13.1.11	Timeout Time	0	65535	s	30	629	
P13.1.12	Contrast Adjust	5	18		12	630	
P13.1.13	Backlight Time	1	65535	min	10	631	
P13.1.14	Fan Control				2	632	0 = Continuous 1 = Temperature 2 = Run Follow 3 = Calculate IGBT Temp
P13.1.15	Keypad ACK Timeout	200	5000	ms	200	633	
P13.1.16	Keypad Retry Number	1	10		5	634	
P13.1.17	Startup Wizard				0	626	0 = Yes 1 = No
P13.1.18 ②	Jog Softkey Hidden				0	2412	See Par ID 1679
P13.1.19 ②	Reverse Softkey Hidden				0	2413	See Par ID 1679
P13.1.20 ②	Output Display Unit				45	2424	0 = % 1 = 1/min 2 = rpm 3 = ppm 4 = pps 5 = l/s 6 = l/min 7 = l/h 8 = kg/s 9 = kg/min 10 = kg/h 11 = m3/s 12 = m3/min 13 = m3/h 14 = m/s 15 = mbar 16 = bar 17 = Pa 18 = kPa 19 = mVS 20 = kW 21 = °C 22 = GPM 23 = gal/s 24 = gal/min 25 = gal/h 26 = lb/s 27 = lb/min 28 = lb/h 29 = CFM 30 = ft3/s 31 = ft3/min 32 = ft3/h 33 = ft/s 34 = in wg 35 = ft wg 36 = PSI 37 = lb/in2 38 = HP 39 = °F 40 = PA 41 = WC 42 = HG 43 = ft 44 = m 45 = Hz 46 = strokes/min
P13.1.21 ②	Output Display Unit Min	-60000.00	See Par ID 2425	Varies	0.00	2460	
P13.1.22 ②	Output Display Unit Max	See Par ID 2460	60000.00	Varies	Varies	2425	

Notes: ② Parameter value can only be changed after the drive has stopped.
② Parameter value will be set to be default when changing macros.

Table 57. Version Info — P13.2

Code	Parameter	Min.	Max.	Unit	Default	ID	Note
P13.2.1	Keypad Software Version					640	
P13.2.2	Motor Control Software Version					642	
P13.2.3	Application Software Version					644	
P13.2.4	Software Bundle Version					1714	

Table 58. Application Info — P13.3

Code	Parameter	Min.	Max.	Unit	Default	ID	Note
P13.3.1	Brake Chopper					646	See Par ID 2118
P13.3.2	Brake Resistor Status					647	See Par ID 2118
P13.3.3	Serial Number					648	

Table 59. User Info — P13.4

Code	Parameter	Min.	Max.	Unit	Default	ID	Note
P13.4.1	Real Time Clock				0.0.0.1:1:13	566	
P13.4.2	Daylight Saving				0	582	0 = Off 1 = EU 2 = US
P13.4.3	Total MWh Count			Mwh		601	
P13.4.4	Total Power Day Count					603	
P13.4.5	Total Power Hr Count					606	
P13.4.6	Trip MWh Count			Mwh		604	
P13.4.7	Clear Trip MWh Count					635	See Par ID 2125
P13.4.8	Trip Power Day Count					636	
P13.4.9	Trip Power Hr Count					637	
P13.4.10	Clear Trip Power Count					639	See Par ID 2125

Table 60. Operate Mode — O

Code	Parameter	Min.	Max.	Unit	Default	ID	Note
O1	Output Frequency			Hz		1	
O2	Freq Reference			Hz		24	
O3	Motor Speed			rpm		2	
O4	Motor Current			A		3	
O5	Motor Torque			%		4	
O6	Motor Power			%		5	
O7	Motor Voltage			V		6	
O8	DC-link Voltage			V		7	
O9	Unit Temperature			°		8	
O10	Motor Temperature			%		9	
R11 ②	Keypad Reference	See Par ID 101	See Par ID 102	Hz	0.00	141	

Notes: ① Parameter value can only be changed after the drive has stopped.

② Parameter value will be set to be default when changing macros.

Chapter 6 — PID application

Introduction

The PID Application is designed for preloaded application sets for use with HVAC specific terminology and functions when using PID control loops internal to the drive. This is typically used with pump or fan process systems to maintain a desired set point level. With using the PID Controller reference selection the drive is setup to receive a setpoint level from any of the standard control location and then it also gets a feedback from typically some analog sensor to indicate actual process conditions, then from there it will adjust the output of the drive or an analog output to meet the setpoint level. The reaction of this adjustment on the output is determined by a Gain variable and an integral time for most setups and can include the Derivative time. It also will allow the drive to go into a sleep mode to prevent continue run time and wear on the system. In addition it includes all the standard settings from the previous Basic Application in addition to a 2nd Motor parameter set for control of 2 different motors with the same drive. It provides the ability for the user to define its Hand and Auto control and reference signals with the standard Off condition as well. In addition there is the ability to scale the analog input and output signals to be read based off the desired motor response. There are also 8 digital inputs, 3 relay outputs, and 1 digital output that can be programmed to allow for control schemes that require the drive to have certain functions. It provides full customization on the motor control sequence with the ability to be in frequency or speed control mode, and tuning of the V/Hz curve can be selected. Drive/ Motor protections can be customized to defined actions for added user control. Below is a list of other features that are available in the PID Application.

PID Application includes functions:

- Bypass Control
- Fire Mode
- Damper Control
- Pre heat/cold weather mode
- Hand/Off/Auto in individual button for easy change of control mode.
- Damper Control
- Programmable Protections
- Programmable digital/analog input/output function
- Programmable start/stop signal logic
- Voltage and Current limiters
- Energy Savings Calculator
- Two independent set of Acceleration/Deceleration ramps
- Skip frequency

- Start source (Local/Remote control function)
- Reference source
- Flying start
- Volts per Hertz control programmable
- Real time clock—RTC time display
- RTC Timers and Interval control
- Auto restart on fault to drive or bypass
- Programmable switching frequency
- Multi-Preset speeds
- Fan control

I/O controls

• Terminal To Function (TTF) Programming

The design behind the programming of the digital inputs in the VS3 drive is to use “Terminal To Function” programming, which is composed of multiple functions that get assigned a digital input to that function. The parameters in the drive are set up with specific functions and by defining the digital input and slot in some cases, depending on which options are available. For use of the drives control board inputs, they will be referred to as DigIN:1 through DigIN:8. When additional option cards are used, they will be defined as DigIN:X:IOY:Z. The X indicates the slot that the card is being installed in, which will be either A or B. The IOY determines the type of card it is, which would be IO1 or IO5. The Z indicates which input is being used on that available option card.

• Function To Terminal (FTT) Programming

The design behind the programming of the relay outputs and digital output in the VS3 drive is to use “Function To Terminal” programming. It is composed of a terminal, be it a relay output or a digital output, that is assigned a parameter. Within that parameter, it has different functions that can be set.

The parameters of the Standard Application are explained in Appendix A of this manual, “Description of Parameters.”

The explanations are arranged according to the parameter number. For the DI function, we use Terminal programming method to function (TTF), where there is a fixed input that gets programmed to a list of functions. This allows for multiple inputs to be used for different functions. Connecting a certain input with a certain parameter function is done by give a parameter an appropriate value. The value is formed by the location of the input, either being on the standard control board or an external option board and the slot it is located in.

Force open/force close selection

The Force Open Selection would make the selected function always off. Essentially this is a virtual switch that is always open. The Force Close Selection would make the selected function always on. Essentially this is a virtual switch that is always closed. These options are assigned to a function if we want to force a state without using a hardware input.

The standard options are DigIn: Force Open - indication that the parameter function is always going to be open, that being said depending on the logic of the function this could mean the function is always not active or always active. When the selection of a function is DigIn: Force Closed - indication that the parameter function is always going to be closed, that being said again depending on the location of the function this could mean the function is always active or not active. Examples of these options would be ID190 Start Signal 1, when set to "Force Open" and the drive is looking at I/O terminals for control, in this case the drive would never start since this Function is always Open. If this function is set to "Force closed" the drive would always be in a start mode when in that control location.

Example:

If we set Run Enable to Force Closed the drive is always enabled. If we set the same function to Force Open the drive would never be Enabled. If a Digital input is to be used to activate this Run Enable the function should be assigned to a hardware input(See below for DIGIN Selections).

DIGIN selection

This allows Assignment of a hardware digital input to a function, this is set in a format of DigIN:X where X is one of the 8 Digital inputs on the Main control board.

Example:

If we set Run Enable to DigIN:6 the drive will be enabled when digital input 6 (Terminal 8) is closed, and would not be enabled when digital input 6 (Terminal 8) is open.

Option board DigIN selection

This allows Assignment of a hardware digital input on an option card to a function, this is set in a format of DigIN:Y:IO1:X where Y is the slot the option card is inserted on the Main control board and X is the Input on the Board and IO1 is the type of option board used.

Example:

If we set Run Enable to DigIN:A:IO5:6 the drive will be enabled when digital input 6 is closed on the IO5 option card which is inserted in Slot A, and would not be enabled when digital input 6 on the option card is open.

Timer channel selection

A Time Channel is a virtual path to link the digital output of a timer function to a digital input function. To utilize this feature a timer or interval would need to be assigned to a time channel 1 through 3, and the input function to be controlled would need to be assigned to the same time channel.

Example:

If we set Run Enable to DigIN:TimeChannel1 the drive will be enabled when the timer assigned to Time Channel 1 is active or High, and would not be enabled when the Time Channel is inactive or Low.

Control I/O configuration

- Run 240 Vac and 24 Vdc control wiring in separate conduit
- Communication wire to be shielded

Table 61. PID application default I/O connection

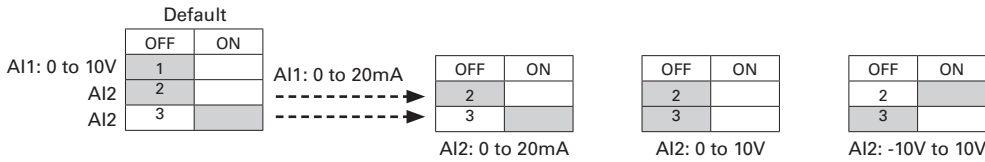

External Wiring	Pin	Signal Name	Signal	Default Setting	Description
	1	+10V	Ref. Output Voltage	-	10VDC Supply Source
	2	AI1+ [Ⓞ]	Analog Input 1	0-10V	Voltage Speed Reference (Programmable to 4-20mA)
	3	AI1-	Analog Input 1 Ground	-	Analog Input 1 Common (Ground)
	4	AI2+ [Ⓞ]	Analog Input 2	4-20mA	Current Speed Reference (Programmable to 0-10V)
	5	AI2-	Analog Input 2 Ground	-	Analog Input 2 Common (Ground)
	6	GND	I/O Signal Ground	-	I/O Ground for Reference and Control
	7	DIN5	Digital Input 5	Preset Speed B0	Sets frequency output to Preset Speed 1
	8	DIN6	Digital Input 6	Fire Mode	Enables drive into Fire Mode
	9	DIN7	Digital Input 7\TI+	Bypass Start	Enables drive into Bypass mode waiting for drive start
	10	DIN8	Digital Input 8\TI-	Force Auto	Input forces drive into Auto Control place
	11	CMB	DI5 to DI8 Common	Grounded	Allows source input
	12	GND	I/O Signal Ground	-	I/O Ground for Reference and Control
	13	24Vo	+24VDC Output	-	Control voltage output (100mA Max)
	14	DO1	Digital Output 1	Ready	Shows the drive is ready to run
	15	24Vo	+24VDC Output	-	Control voltage output (100mA Max)
	16	GND	I/O Signal Ground	-	I/O Ground for Reference and Control
	17	AO1+	Analog Output 1	Output Frequency	Shows Output frequency to motor 0 - 60Hz (4-20mA)
	18	AO2+	Analog Output 2	Motor Current	Shows Motor current of motor 0-FLA (4-20mA)
	19	24Vi	+24VDC Input	-	External control voltage input
	20	DIN1	Digital Input 1	Run Forward	Input starts drive in forward direction (start enable)
	21	DIN2	Digital Input 2	Run Reverse	Input starts drive in reverse direction(start enable)
	22	DIN3	Digital Input 3	External Fault	Input causes drive to fault
	23	DIN4	Digital Input 4	Fault Reset	Input resets active faults
	24	CMA	DI1 to DI4 Common	Grounded	Allows source input
	25	A	RS-485 Signal A/+	-	Fieldbus Communication (Modbus, BACnet)
	26	B	RS-485 Signal B/-	-	Fieldbus Communication (Modbus, BACnet)
	27	R3NO	Relay 3 Normally Open	Fault	Relay output 3 shows VFD is Faulted
	28	R1NC	Relay 1 Normally Closed	Bypass Run	Relay output 1 shows VFD is in a bypass run state
	29	R1CM	Relay 1 Common		
	30	R1NO	Relay 1 Normally Open		
	31	R3CM	Relay 3 Common	Fault	Relay output 3 shows VFD is Faulted
	32	R2NC	Relay 2 Normally Closed	Run	Relay output 2 shows VFD is in a drive run state
	33	R2CM	Relay 2 Common		
	34	R2NO	Relay 2 Normally Open		

Note: The above wiring demonstrates a SINK configuration. It is important that CMA and CMB are wired to ground (as shown by dashed line). If a SOURCE configuration is desired, wire 24 V to CMA and CMB and close the inputs to ground. When using the +10 V for AI1, it is important to wire AI1—ground (as shown by dashed line). If using +10 V for AI1 or AI2, terminals 3, 5, and 6 need to be jumpered together.

[Ⓞ] AI1+ and AI2+ Support 10K potentiometer.

Table 62. Drive communication ports

Port	Communication
RJ45 Keypad Port	
Upload/Download Parameters	USB to RJ45
Remote Mount Keypad	Ethernet
Upgrade Drive Firmware	USB to RJ45
RJ45 Ethernet Port	
Upload/Download Parameters	Ethernet
BACnet IP Communications	Ethernet
Modbus TCP Communications	Ethernet
RS-485 Serial Port ^①	
Upload/Download Parameters	
Upgrade Drive Firmware	Two-Wire Twisted Pair
Modbus RTU Communications	Two-Wire Twisted Pair
BACnet MS/TP Communications	Two-Wire Twisted Pair

^① Shielded wire recommended.

PID application—parameters list

On the next pages you will find the lists of parameters within the respective parameter groups. The parameter descriptions

are given in Appendix A, “Description of Parameters.”

The descriptions are arranged according to the parameter number.

Column explanations:

Code = Location indication on the keypad; shows the operator the present parameter number

Parameter = Name of parameter

Min = Minimum value of parameter

Max = Maximum value of parameter

Unit = Unit of parameter value; given if available

Default = Value preset by factory

ID = ID number of the parameter

Chapter 6 — PID Application

Table 63. Basic - M1

Code	Parameter	Min.	Max.	Unit	Default	ID	Note
M1.1	Output Frequency			Hz	1		
M1.2	Freq Reference			Hz	24		
M1.3	Motor Speed			rpm	2		
M1.4	Motor Current			A	3		
M1.5	Motor Torque			%	4		
M1.6	Motor Power			%	5		
M1.7	Motor Voltage			V	6		
M1.8	DC-link Voltage			V	7		
M1.9	Unit Temperature			°C	8		
M1.10	Motor Temperature			%	9		
M1.11	Latest Fault Code				28		
M1.12	Instant Motor Power			kW	1686		
M1.13	RTC Battery Status				583		0 = Not Installed 1 = Installed 2 = Change Battery 3 = OverVoltage

Table 64. IO Status — M2

Code	Parameter	Min.	Max.	Unit	Default	ID	Note
M2.1	Analog Input 1			Varies		10	
M2.2	Analog Input 2			Varies		11	
M2.3	Analog Output 1			Varies		25	
M2.4	Analog Output 2			Varies		575	
M2.5	DI1, DI2, DI3					12	
M2.6	DI4, DI5, DI6					13	
M2.7	DI7, DI8					576	
M2.8	DO1,Virtual RO1,Virtual RO2					14	
M2.9	RO1, RO2, RO3					557	

Table 65. Optional Boards — M3

Code	Parameter	Min.	Max.	Unit	Default	ID	Note
M3.1	PT100 Temperture			°C	1000.0	27	

Table 66. Energy Savings — M4

Code	Parameter	Min.	Max.	Unit	Default	ID	Note
M4.1 [Ⓢ]	Energy Savings			Varies	0.000	2120	

Table 67. FB Monitor Menu — M5

Code	Parameter	Min.	Max.	Unit	Default	ID	Note
M5.1	Control Board DIDO Status					2209	Bit 0 = DIN1 Status Bit 1 = DIN2 Status Bit 2 = DIN3 Status Bit 3 = DIN4 Status Bit 4 = DIN5 Status Bit 5 = DIN6 Status Bit 6 = DIN7 Status Bit 7 = DIN8 Status Bit 8 = DO1 Status Bit 9 = R01 Status Bit 10 = R02 Status Bit 11 = R03 Status Bit 12 = SlotA with board Bit 13 = SlotB with board Bit 14 = Virtual R01 Status Bit 15 = Virtual R02 Status
M5.2	SlotA DIDO Status					2210	Bit 0 = IO1_DIN1 Status Bit 1 = IO1_DIN2 Status Bit 2 = IO1_DIN3 Status Bit 3 = IO1_DO1 Status Bit 4 = IO1_DO2 Status Bit 5 = IO1_DO3 Status Bit 6 = IO3_R01 Status Bit 7 = IO3_R02 Status Bit 8 = IO3_R03 Status Bit 9 = IO5_AC1 Status Bit 10 = IO5_AC2 Status Bit 11 = IO5_AC3 Status Bit 12 = IO5_AC4 Status Bit 13 = IO5_AC5 Status Bit 14 = IO5_AC6 Status
M5.3	SlotB DIDO Status					2211	Bit 0 = IO1_DI1 Bit 1 = IO1_DI2 Bit 2 = IO1_DI3 Bit 3 = IO1_DO1 Bit 4 = IO1_DO2 Bit 5 = IO1_DO3 Bit 6 = IO3_R01 Bit 7 = IO3_R02 Bit 8 = IO3_R03 Bit 9 = IO5_AC1 Bit 10 = IO5_AC2 Bit 11 = IO5_AC3 Bit 12 = IO5_AC4 Bit 13 = IO5_AC5 Bit 14 = IO5_AC6 Bit 15 = Not Used

Chapter 6 — PID Application

Table 67. FB Monitor Menu — M5, continued

Code	Parameter	Min.	Max.	Unit	Default	ID	Note
M5.4	Application Status Word					29	Bit 0 = MC_Ready Bit 1 = MC_Run Bit 2 = MC_Fault or Fault Trip Bit 3 = FB_Ref_Active Bit 4 = MC_Stopping Bit 5 = MC_Reverse Bit 6 = MC_Warning or AR Bit 7 = MC_ZeroSpeed Bit 8 = IO Control Indicator Bit 9 = Panel Control Indicator Bit 10 = Panel Fieldbus Control Indicator Bit 11 = MC_DC_Brake Bit 12 = RunEnable Bit 13 = Run Bypass Bit 14 = External Brake Control Bit 15 = In Bypass Mode
M5.5	Standard Status Word					2414	Bit 0 = See PAR ID 2415(default = Ready) Bit 1 = See PAR ID 2416(default = Run) Bit 2 = See PAR ID 2417(default = Fault) Bit 3 = See PAR ID 2418(default = Fault Invert) Bit 4 = See PAR ID 2419(default = Warning) Bit 5 = See PAR ID 2420(default = Reversed) Bit 6 = See PAR ID 2421(default = At Speed) Bit 7 = See PAR ID 2422(default = Zero Frequency) Bit 8 - 15 = Not Used

Table 68. PID Monitor — M6

Code	Parameter	Min.	Max.	Unit	Default	ID	Note
M6.1	PID1 Set Point			Varies		16	
M6.2	PID1 Feedback			Varies		18	
M6.3	PID1 Error Value			Varies		20	
M6.4	PID1 Output			%		22	
M6.5	PID1 Status					23	0 = Stopped 1 = Running 2 = Sleep Mode
M6.6	PID2 Set Point			Varies		32	
M6.7	PID2 Feedback			Varies		34	
M6.8	PID2 Error Value			Varies		36	
M6.9	PID2 Output			%		38	
M6.10	PID2 Status					39	See Par ID 23

Table 69. Timer/Interval Control — M7

Code	Parameter	Min.	Max.	Unit	Default	ID	Note
M7.1	TC1, TC2, TC3					558	
M7.2	Interval 1					559	0 = Inactive 1 = Active
M7.3	Interval 2					560	See Par ID 559
M7.4	Interval 3					561	See Par ID 559
M7.5	Interval 4					562	See Par ID 559
M7.6	Interval 5					563	See Par ID 559
M7.7	Timer 1			s	0	569	
M7.8	Timer 2			s	0	571	
M7.9	Timer 3			s	0	573	

Table 70. User Defined Output — M8

Code	Parameter	Min.	Max.	Unit	Default	ID	Note
M8.1	Output			Varies		2445	
M8.2	Reference			Varies		2447	

Table 71. MWH Monitor — M9

Code	Parameter	Min.	Max.	Unit	Default	ID	Note
M9.1	Total MWh Count			Mwh		601	
M9.2	Total Power Day Count					603	
M9.3	Total Power Hr Count					606	
M9.4	Trip MWh Count			Mwh		604	
M9.5	Trip Power Day Count					636	
M9.6	Trip Power Hr Count					637	

Table 72. Multi-Monitoring — M10

Code	Parameter	Min.	Max.	Unit	Default	ID	Note
M10.1	Multi-Monitoring				1,2,3	30	

Parameters

Table 73. Basic Parameters — P1

Code	Parameter	Min.	Max.	Unit	Default	ID	Note
P1.1 ①②	Min Frequency	0.00	See Par ID 102	Hz	0.00	101	
P1.2 ①②	Max Frequency	See Par ID 101	400.00	Hz	Varies	102	
P1.3 ②	Accel Time 1	0.1	3000.0	s	20.0	103	
P1.4 ②	Decel Time 1	0.1	3000.0	s	20.0	104	
P1.5 ①	Motor Nom Current	DriveNomCurrCT*1/10	DriveNomCurrCT*2	A	DriveNomCurrCT	486	
P1.6 ①	Motor Nom Speed	300	20000	rpm	Varies	489	
P1.7 ①	Motor PF	0.30	1.00		0.85	490	
P1.8 ①	Motor Nom Voltage	180	690	V	Varies	487	
P1.9 ①	Motor Nom Frequency	8.00	400.00	Hz	Varies	488	
P1.10 ①②	HOA Source				0	2465	0 = I/O Terminal/Keypad/Fieldbus 1 = Keypad 2 = IO Terminal 3 = Fieldbus
P1.11 ②	Hand Control Place				0	1695	0 = Keypad 1 = I/O Terminal Start 1 2 = I/O Terminal Start 2 3 = Fieldbus
P1.12 ①②	Hand Reference				6	136	0 = AI1 1 = AI2 2 = Slot A: AI1 3 = Slot B: AI1 6 = Keypad 7 = Fieldbus Ref 9 = Max Frequency 10 = AI1 + AI2 11 = AI1 - AI2 12 = AI2 - AI1 13 = AI1 * AI2 14 = AI1 or AI2 15 = MIN(AI1,AI2) 16 = MAX(AI1,AI2) 17 = PID1 Control Output 18 = PID2 Control Output
P1.13 ②	Auto 1 Control Place				0	135	0 = I/O Terminal Start 1 1 = Fieldbus 2 = I/O Terminal Start 2 3 = Keypad
P1.14 ①②	Auto 1 Reference				1	137	See Par ID 136
P1.15 ②	Auto 2 Control Place				1	138	See Par ID 135
P1.16 ①②	Auto 2 Reference				7	139	See Par ID 136

Inputs

Table 74. Basic Setting — P2.1

Code	Parameter	Min.	Max.	Unit	Default	ID	Note
P2.1.1 ①②	Damper Start				0	483	0 = Normal 1 = Interlock Start 2 = Interlock Tout 3 = Interlock Delay
P2.1.2 ①②	Damper Time Out	1	32500	s	5	484	
P2.1.3 ①②	Damper Delay	1	32500	s	5	485	
P2.1.4 ②	AI Ref Scale Min Value	0.00	See Par ID 145	Hz	0.00	144	
P2.1.5 ②	AI Ref Scale Max Value	See Par ID 144	400.00	Hz	0.00	145	

Note: ① Parameter value can only be changed after the drive has stopped.

② Parameter value will be set to be default when changing macros.

Table 75. Digital Input — P2.2

Code	Parameter	Min.	Max.	Unit	Default	ID	Note
P2.2.1 ①②	IO Terminal 1 Start Stop Logic				0	143	0 = Forward - Reverse 0 = Forward - Reverse 1 = Start - Reverse 2 = Start - Enable 3 = Start Pulse - Stop Pulse
P2.2.2 ②③						190	0 = DigIN:NormallyOpen 1 = DigIN:NormallyClose 2 = DigIN: 1 3 = DigIN: 2 4 = DigIN: 3 5 = DigIN: 4 6 = DigIN: 5 7 = DigIN: 6 8 = DigIN: 7 9 = DigIN: 8 10 = DigIN: A: IO1: 1 11 = DigIN: A: IO1: 2 12 = DigIN: A: IO1: 3 13 = DigIN: A: IO5: 1 14 = DigIN: A: IO5: 2 15 = DigIN: A: IO5: 3 16 = DigIN: A: IO5: 4 17 = DigIN: A: IO5: 5 18 = DigIN: A: IO5: 6 19 = DigIN: B: IO1: 1 20 = DigIN: B: IO1: 2 21 = DigIN: B: IO1: 3 22 = DigIN: B: IO5: 1 23 = DigIN: B: IO5: 2 24 = DigIN: B: IO5: 3 25 = DigIN: B: IO5: 4 26 = DigIN: B: IO5: 5 27 = DigIN: B: IO5: 6 28 = Time Channel 1 29 = Time Channel 2 30 = Time Channel 3 31 = RO1 Function 32 = RO2 Function 33 = RO3 Function 34 = Virtual RO1 Function 35 = Virtual RO2 Function
P2.2.3 ②③						191	See Par ID 190
P2.2.4 ①②						2206	See Par ID 143
P2.2.5 ②③						2207	See Par ID 190
P2.2.6 ②③						2208	See Par ID 190
P2.2.7 ①②						881	0 = Digital Input 1 = Thermistor Input
P2.2.8 ②③						198	See Par ID 190
P2.2.9 ②③						192	See Par ID 190
P2.2.10 ②③						193	See Par ID 190
P2.2.11 ②						2297	0 = External Fault 1 = Vibration Cut out 2 = High Motor temp 3 = Low Pressure 4 = High Pressure 5 = Low Water 6 = Damper Interlock 7 = Run Enable 8 = Freeze Stat Trip 9 = Smoke Detect 10 = Seal Leakage 11 = Rod Breakage

Note: ① Parameter value can only be changed after the drive has stopped.
 ② Parameter value will be set to be default when changing macros.
 ③ Input function is level sensed.
 ④ Input function is edge sensed when using StartP/StopP start logic.

Chapter 6 — PID Application

Table 75. Digital Input — P2.2, continued

Code	Parameter	Min.	Max.	Unit	Default	ID	Note
P2.2.12 ②③	Ext. Fault 2 NO				0	2293	See Par ID 190
P2.2.13 ②③	Ext. Fault 2 NC				1	2294	See Par ID 190
P2.2.14 ②	Ext. Fault 2 Text				1	2298	See Par ID 2297
P2.2.15 ②③	Ext. Fault 3 NO				0	2295	See Par ID 190
P2.2.16 ②③	Ext. Fault 3 NC				1	2296	See Par ID 190
P2.2.17 ②③	Ext. Fault 3 Text				2	2299	See Par ID 2297
P2.2.18 ②④	Fault Reset				5	200	See Par ID 190
P2.2.19 ②③	Run Enable				1	194	See Par ID 190
P2.2.20 ②③	Preset Speed B0				6	205	See Par ID 190
P2.2.21 ②③	Preset Speed B1				0	206	See Par ID 190
P2.2.22 ②③	Preset Speed B2				0	207	See Par ID 190
P2.2.23 ②③	Jog Enable				0	199	See Par ID 190
P2.2.24 ②③	Accel/Decel Time Set				0	195	See Par ID 190
P2.2.25 ②③	Accel/Decel Prohibit				0	201	See Par ID 190
P2.2.26 ②④	No Access To Param				0	215	See Par ID 190
P2.2.27 ②③	Auto Control				9	196	See Par ID 190
P2.2.28 ②③	Hand Control				0	197	See Par ID 190
P2.2.29 ②③	Auto 1/2 Select				0	209	See Par ID 190
P2.2.30 ②③	HOA On/Off				1	2395	See Par ID 190
P2.2.31 ②③	Second Motor Para Select				0	217	See Par ID 190
P2.2.32 ②④	Parameter Set1/2 Sel				0	2312	See Par ID 190
P2.2.33 ②③	AI Ref Source Select				0	208	See Par ID 190
P2.2.34 ②③	Bypass Start				8	218	See Par ID 190
P2.2.35 ②③	Bypass Overload				0	1246	See Par ID 190
P2.2.36 ②③	PID1 Control Enable				1	550	See Par ID 190
P2.2.37 ②③	PID2 Control Enable				1	553	See Par ID 190
P2.2.38 ②③	PID1 Set Point Select				0	351	See Par ID 190
P2.2.39 ②③	PID2 Set Point Select				0	352	See Par ID 190
P2.2.40 ②③	DC Brake Active				0	202	See Par ID 190
P2.2.41 ②③	Smoke Mode				0	219	See Par ID 190
P2.2.42 ②③	Fire Mode				7	220	See Par ID 190
P2.2.43 ②③	Fire Mode Ref 1/2 Select				0	221	See Par ID 190
P2.2.44 ②③	Fire Mode Reverse				0	2119	See Par ID 190
P2.2.45 ②③	Start Timer 1				0	224	See Par ID 190
P2.2.46 ②③	Start Timer 2				0	225	See Par ID 190
P2.2.47 ②③	Start Timer 3				0	226	See Par ID 190

Note: ② Parameter value will be set to be default when changing macros.

③ Input function is level sensed.

④ Input function is edge sensed.

Table 76. Preset Speed — P2.3

Code	Parameter	Min.	Max.	Unit	Default	ID	Note
P2.3.1 ②	Preset Speed 1	0.00	See Par ID 102	Hz	5.00	105	
P2.3.2 ②	Preset Speed 2	0.00	See Par ID 102	Hz	10.00	106	
P2.3.3 ②	Preset Speed 3	0.00	See Par ID 102	Hz	15.00	118	
P2.3.4 ②	Preset Speed 4	0.00	See Par ID 102	Hz	20.00	119	
P2.3.5 ②	Preset Speed 5	0.00	See Par ID 102	Hz	25.00	120	
P2.3.6 ②	Preset Speed 6	0.00	See Par ID 102	Hz	30.00	121	
P2.3.7 ②	Preset Speed 7	0.00	See Par ID 102	Hz	35.00	122	
P2.3.8 ②	Jog Reference	See Par ID 101	See Par ID 102	Hz	0.00	117	

Table 77. AI1 Settings — P2.4

Code	Parameter	Min.	Max.	Unit	Default	ID	Note
P2.4.1	AI1 Mode				1	222	0 = 0 - 20 mA 1 = 0 -10 V
P2.4.2 ②	AI1 Signal Range				0	175	0 = 0-100%/0-20mA/0-10V 1 = 20-100%/4-20mA/2-10V 2 = Customized
P2.4.3 ②	AI1 Custom Min	0.00	See Par ID 177	%	0.00	176	
P2.4.4 ②	AI1 Custom Max	See Par ID 176	100.00	%	100.00	177	
P2.4.5 ②	AI1 Filter Time	0.00	10.00	s	0.10	174	
P2.4.6 ②	AI1 Signal Invert				0	181	0 = Not Inverted 1 = Inverted

Table 78. AI2 Settings — P2.5

Code	Parameter	Min.	Max.	Unit	Default	ID	Note
P2.5.1	AI2 Mode				0	223	0 = 0 - 20 mA 1 = 0 -10 V 2 = -10 - +10 V
P2.5.2 ②	AI2 Signal Range				1	183	0 = 0-100%/0-20mA/0-10V/-10-10V 1 = 20-100%/4-20mA/2-10V/-6-10V 2 = Customized
P2.5.3 ②	AI2 Custom Min	0.00	See Par ID 185	%	0.00	184	
P2.5.4 ②	AI2 Custom Max	See Par ID 184	100.00	%	100.00	185	
P2.5.5 ②	AI2 Filter Time	0.00	10.00	s	0.10	182	
P2.5.6 ②	AI2 Signal Invert				0	189	See Par ID 181

Note: ① Parameter value can only be changed after the drive has stopped.

② Parameter value will be set to be default when changing macros.

③ Input function is level sensed.

Outputs

Table 79. Digital Output — P3.1

Code	Parameter	Min.	Max.	Unit	Default	ID	Note
P3.1.1 ©	D01 Function				1	151	0 = Not Used 1 = Ready 2 = Run 3 = Fault 4 = Fault Invert 5 = Warning 6 = Reversed 7 = At Speed 8 = Zero Frequency 9 = Freq Limit 1 Superv 10 = Freq Limit 2 Superv 11 = PID1 Superv 12 = PID2 Superv 13 = OverHeat Fault 14 = OverCurrent Regular 15 = OverVoltage Regular 16 = UnderVoltage Regular 17 = 4mA Ref Fault/Warning 20 = Torq Limit Superv 21 = Ref Limit Superv 22 = Control from I/O 23 = Un-Requested Rotation Direction 24 = Thermistor Fault Output 25 = Fire Mode 26 = In Bypass Mode 27 = Ext Fault/Warning 28 = Auto Control 29 = Jog Speed Select 30 = Motor Therm Protection 31 = FB Digital Input 1 32 = FB Digital Input 2 33 = FB Digital Input 3 34 = FB Digital Input 4 35 = Damper Control 36 = TC1 Status 37 = TC2 Status 38 = TC3 Status 40 = Power Limit Superv 41 = Temp Limit Superv 42 = Analog Input Superv 43 = Motor 1 Control 48 = Logic Fulfilled 49 = PID1 Sleep 50 = PID2 Sleep 51 = Motor Current 1 Supv 52 = Motor Current 2 Supv 53 = Second AI Limit Supv 54 = DC Charge Switch Close 55 = Preheat Active 56 = Cold Weather Active 58 = 2th Stage Ramp Frequency Active 59 = STO Fault Output 60 = Run Bypass/Drive 61 = Bypass Overload 62 = Bypass Run
P3.1.2 ©	R01 Function				62	152	See Par ID 151
P3.1.3 ©	R01 On Delay	0.0	320.0	s	0.0	2112	
P3.1.4 ©	R01 Off Delay	0.0	320.0	s	0.0	2113	
P3.1.5 ©	R02 Function				2	153	See Par ID 151

Note: © Parameter value will be set to be default when changing macros.

Table 79. Digital Output — P3.1, continued

Code	Parameter	Min.	Max.	Unit	Default	ID	Note
P3.1.6 ②	R02 On Delay	0.0	320.0	s	0.0	2114	
P3.1.7 ②	R02 Off Delay	0.0	320.0	s	0.0	2115	
P3.1.8 ②	R03 Function				3	538	See Par ID 151
P3.1.9 ②	R03 On Delay	0.0	320.0	s	0.0	2116	
P3.1.10 ②	R03 Off Delay	0.0	320.0	s	0.0	2117	
P3.1.11 ②	R03 Reverse				0	2118	0 = No 1 = Yes
P3.1.12 ②	Virtual R01 Function				0	2463	See Par ID 151
P3.1.13 ②	Virtual R02 Function				0	2464	See Par ID 151

Table 80. Supervisions — P3.2

Code	Parameter	Min.	Max.	Unit	Default	ID	Note
P3.2.1 ②	Freq Limit 1 Supv				0	154	0 = No Limit 1 = Low Limit Superv 2 = High Limit Superv
P3.2.2 ②	Freq Limit 1 Supv Val	0.00	See Par ID 102	Hz	0.00	155	
P3.2.3 ②	Freq Limit 1 Supv Hyst	0.10	1.00	Hz	0.10	2200	
P3.2.4 ②	Freq Limit 2 Supv				0	157	See Par ID 154
P3.2.5 ②	Freq Limit 2 Supv Val	0.00	See Par ID 102	Hz	0.00	158	
P3.2.6 ②	Freq Limit 2 Supv Hyst	0.10	1.00	Hz	0.10	2201	
P3.2.7 ②	Torque Limit Supv				0	159	See Par ID 154
P3.2.8 ②	Torque Limit Supv Val	-1000.0	1000.0	%	100.0	160	
P3.2.9 ②	Torque Limit Supv Hyst	1.0	5.0	%	1.0	2202	
P3.2.10 ②	Ref Limit Supv				0	161	See Par ID 154
P3.2.11 ②	Ref Limit Supv Val	0.00	See Par ID 102	Hz	0.00	162	
P3.2.12 ②	Ref Limit Supv Hyst	0.10	1.00	Hz	0.10	2203	
P3.2.13 ②	Temp Limit Supv				0	165	See Par ID 154
P3.2.14 ②	Temp Limit Supv Val	-10.0	75.0	°C	40.0	166	
P3.2.15 ②	Temp Limit Supv Hyst	1.0	10.0	°C	1.0	2204	
P3.2.16 ②	Power Limit Supv				0	167	See Par ID 154
P3.2.17 ②	Power Limit Supv Val	-200.0	200.0	%	0.0	168	
P3.2.18 ②	Power Limit Supv Hyst	0.1	10.0	%	0.1	2205	
P3.2.19 ②	AI Supv Select				0	170	0 = AI1 1 = AI2
P3.2.20 ②	AI Limit Supv				0	171	See Par ID 154
P3.2.21 ②	AI Limit Supv Val	0.00	100.00	%	0.00	172	
P3.2.22 ②	AI Supv Hyst	1.00	10.00	%	1.00	2198	
P3.2.23 ②	Motor Current 1 Supv				0	2189	See Par ID 154
P3.2.24 ②	Motor Current 1 Supv Value	0.0	DriveNomCurrCT*2	A	DriveNomCurrCT	2190	
P3.2.25 ②	Motor Current 1 Supv Hyst	0.1	1.0	A	0.1	2196	
P3.2.26 ②	Motor Current 2 Supv				0	2191	See Par ID 154
P3.2.27 ②	Motor Current 2 Supv Value	0.0	DriveNomCurrCT*2	A	DriveNomCurrCT	2192	
P3.2.28 ②	Motor Current 2 Supv Hyst	0.1	1.0	A	0.1	2197	
P3.2.29 ②	Second AI Supv Select				0	2193	See Par ID 170
P3.2.30 ②	Second AI Limit Supv				0	2194	See Par ID 154
P3.2.31 ②	Second AI Limit Supv Val	0.00	100.00	%	0.00	2195	
P3.2.32 ②	Second AI Supv Hyst	1.00	10.00	%	1.00	2199	

Note: ② Parameter value will be set to be default when changing macros.

Chapter 6 — PID Application

Table 80. Supervisions — P3.2, continued

Code	Parameter	Min.	Max.	Unit	Default	ID	Note
P3.2.33 ②	PID1 Superv Enable				0	1346	0 = Disabled 1 = Enabled
P3.2.34 ②	PID1 Superv Upper Limit	See Par ID 1298	See Par ID 1300	Varies	0.00	1347	
P3.2.35 ②	PID1 Superv Lower Limit	See Par ID 1298	See Par ID 1300	Varies	0.00	1349	
P3.2.36 ②	PID1 Superv Delay	0	3000	s	0	1351	
P3.2.37 ②	PID2 Superv Enable				0	1408	See Par ID 1346
P3.2.38 ②	PID2 Superv Upper Limit	See Par ID 1360	See Par ID 1362	Varies	0.00	1409	
P3.2.39 ②	PID2 Superv Lower Limit	See Par ID 1360	See Par ID 1362	Varies	0.00	1411	
P3.2.40 ②	PID2 Superv Delay	0	3000	s	0	1413	

Table 81. Analog Output 1 — P3.3

Code	Parameter	Min.	Max.	Unit	Default	ID	Note
P3.3.1 ②	A01 Mode				0	227	See Par ID 222
P3.3.2 ②	A01 Function				1	146	0 = Not Used 1 = Output Frequency 2 = Freq Reference 3 = Motor Speed (0-Nom) 4 = Motor Current (0-Nom) 5 = Motor Torque (0-Nom) 6 = Motor Power (0-Nom) 7 = Motor Voltage (0-Nom) 8 = DC-Bus Voltage 9 = PID1 Setpoint 10 = PID1 Feedback 1 11 = PID1 Feedback 2 12 = PID1 Control Error Value 13 = PID1 Control Output 14 = PID2 Setpoint 15 = PID2 Feedback 1 16 = PID2 Feedback 2 17 = PID2 Control Error Value 18 = PID2 Control Output 19 = AI1 20 = AI2 21 = Output Freq (-2-+2N) 22 = Motor Torque (-2-+2N) 23 = Motor Power (-2-+2N) 24 = PT100 Temperature 25 = FB Process Data Input 1 26 = FB Process Data Input 2 27 = FB Process Data Input 3 28 = FB Process Data Input 4 29 = FB Process Data Input 5 30 = FB Process Data Input 6 31 = FB Process Data Input 7 32 = FB Process Data Input 8 33 = SlotA PT100 Temp Channel 1 34 = SlotA PT100 Temp Channel 2 35 = SlotA PT100 Temp Channel 3 36 = SlotB PT100 Temp Channel 1 37 = SlotB PT100 Temp Channel 2 38 = SlotB PT100 Temp Channel 3 39 = User Defined Output 40 = Motor Current (-2-+2N)
P3.3.3 ②	A01 Minimum				1	149	0 = 0V / 0 mA 1 = 2V / 4 mA
P3.3.4 ②	A01 Filter Time	0.00	10.00	s	1.00	147	
P3.3.5 ②	A01 Scale	10	1000	%	100	150	
P3.3.6 ②	A01 Inversion				0	148	See Par ID 181
P3.3.7 ②	A01 Offset	-100.00	100.00	%	0.00	173	

Note: ② Parameter value will be set to be default when changing macros.

Table 82. Analog Output 2 — P3.4

Code	Parameter	Min.	Max.	Unit	Default	ID	Note
P3.4.1 ②	A02 Mode				0	228	See Par ID 222
P3.4.2 ②	A02 Function				4	229	See Par ID 146
P3.4.3 ②	A02 Minimum				1	232	See Par ID 149
P3.4.4 ②	A02 Filter Time	0.00	10.00	s	1.00	230	
P3.4.5 ②	A02 Scale	10	1000	%	100	233	
P3.4.6 ②	A02 Inversion				0	231	See Par ID 181
P3.4.7 ②	A02 Offset	-100.00	100.00	%	0.00	234	

Drive Control

Table 83. Basic Setting — P4.1

Code	Parameter	Min.	Max.	Unit	Default	ID	Note
P4.1.1 ②	Keypad Reference	See Par ID 101	See Par ID 102	Hz	0.00	141	
P4.1.2 ②	Keypad Direction				0	116	0 = Forward 1 = Reverse
P4.1.3 ②	Keypad Stop				1	114	0 = Enabled-Keypad Operation 1 = Always Enabled
P4.1.4 ②	Hand Key Enable				0	1724	0 = Enabled 1 = Disabled
P4.1.5 ②	Reverse Enable				1	1679	See Par ID 1346
P4.1.6	Change PhaseSequence Motor				0	2515	0 = Change Disable 1 = Change Enable
P4.1.7 ②	Power Up HOA Select				0	1685	0 = Hold Last 1 = Hand Control 2 = Auto control 3 = Off
P4.1.9 ②	Run Delay Time	0	32500	s	0	2423	
P4.1.10 ②	Start Mode				0	252	0 = Ramp 1 = Flying Start
P4.1.11 ②	Stop Mode				0	253	0 = Coasting 1 = Ramp
P4.1.12 ②	Ramp 1 Shape	0.0	10.0	s	0.0	247	
P4.1.13 ②	Ramp 2 Shape	0.0	10.0	s	0.0	248	
P4.1.14 ②	Accel Time 2	0.1	3000.0	s	10.0	249	
P4.1.15 ②	Decel Time 2	0.1	3000.0	s	10.0	250	
P4.1.16 ②	Power Loss Function				0	267	See Par ID 1346
P4.1.17 ②	Power Loss Time	0.3	5.0	s	2.0	268	
P4.1.18 ②③	2nd Stage Ramp Frequency	See Par ID 101	See Par ID 102	Hz	30.00	2444	

Note: ② Parameter value can only be changed after the drive has stopped.

③ Parameter value will be set to be default when changing macros.

Chapter 6 — PID Application

Table 84. Brake — P4.2

Code	Parameter	Min.	Max.	Unit	Default	ID	Note
P4.2.1 ①②	DC-Brake Current	DriveNomCurrCT*15/100	DriveNomCurrCT*15/10	A	DriveNomCurrCT*1/2	254	
P4.2.2 ①②	Start DC-Brake Time	0.00	600.00	s	0.00	263	
P4.2.3 ①②	Stop DC-Brake Frequency	0.10	10.00	Hz	1.50	262	
P4.2.4 ①②	Stop DC-Brake Time	0.00	600.00	s	0.00	255	
P4.2.5 ①②	Brake Chopper Define				0	251	0 = Disabled 1 = B(Run) T(Rdy) 2 = External 3 = B(Rdy) T(Rdy) 4 = B(Run) T(No)
P4.2.6 ①②	Flux Brake				0	266	0 = Off 1 = On
P4.2.7 ①②	Flux Brake Current	ActiveMotorNomCurr*1/10	See Par ID 107	A	ActiveMotorNomCurr*1/2	265	

Table 85. Skip Frequency — P4.3

Code	Parameter	Min.	Max.	Unit	Default	ID	Note
P4.3.1 ②	Skip Range Ramp Factor	0.1	10.0		1.0	264	
P4.3.2 ②	Skip F1 Low Limit	0.00	See Par ID 257	Hz	0.00	256	
P4.3.3 ②	Skip F1 High Limit	See Par ID 256	400.00	Hz	0.00	257	
P4.3.4 ②	Skip F2 Low Limit	0.00	See Par ID 259	Hz	0.00	258	
P4.3.5 ②	Skip F2 High Limit	See Par ID 258	400.00	Hz	0.00	259	
P4.3.6 ②	Skip F3 Low Limit	0.00	See Par ID 261	Hz	0.00	260	
P4.3.7 ②	Skip F3 High Limit	See Par ID 260	400.00	Hz	0.00	261	

Table 86. Energy Savings Calc — P4.4

Code	Parameter	Min.	Max.	Unit	Default	ID	Note
P4.4.1 ②	Currency				0	2122	0 = \$ 1 = £ 2 = € 3 = ¥ 4 = ₺ 5 = R\$ 6 = Fr 7 = kr
P4.4.2 ②	Energy Cost			Varies	0.00	2123	
P4.4.3 ②	Data Type				0	2124	0 = Cumulative 1 = Daily Avg 2 = Weekly Avg 3 = Monthly Avg 4 = Yearly Avg
P4.4.4	Energy Savings Reset					2125	0 = Not Reset 1 = Reset

Note: ① Parameter value can only be changed after the drive has stopped.

② Parameter value will be set to be default when changing macros.

Motor Control

Table 87. Basic Setting — P5.1

Code	Parameter	Min.	Max.	Unit	Default	ID	Note
P5.1.1 ①②	Motor Control Mode				0	287	0 = Freq Control 1 = Speed Control
P5.1.2 ①	Current Limit	DriveNomCurrCT*1/10	DriveNomCurrCT*2	A	DriveNomCurrCT*2	107	
P5.1.3 ①②	V/Hz Optimization				0	109	See Par ID 1346
P5.1.4 ①②	V/Hz Ratio				3	108	0 = Linear 1 = Squared 2 = Programmable 3 = Linear + Flux Optimization
P5.1.5 ①②	Field Weakening Point	8.00	400.00	Hz	Varies	289	
P5.1.6 ①②	Voltage at FWP	10.00	200.00	%	100.00	290	
P5.1.7 ①②	V/Hz Mid Frequency	0.00	See Par ID 289	Hz	Varies	291	
P5.1.8 ①②	V/Hz Mid Voltage	0.00	100.00	%	100.00	292	
P5.1.9 ①②	Zero Frequency Voltage	0.00	40.00	%	0.00	293	
P5.1.10 ②	Switching Frequency	MinSwitchFreq	MaxSwitchFreq	kHz	DefaultSwitchFreqCT	288	
P5.1.11 ②	Sine Filter Enable				0	1665	See Par ID 1346
P5.1.12 ①②	OverVoltage Control				1	294	See Par ID 1346

Table 88. Second Motor Parameter — P5.2

Code	Parameter	Min.	Max.	Unit	Default	ID	Note
P5.2.1 ①	Motor Nom Current 2	DriveNomCurrCT*1/10	DriveNomCurrCT*2	A	DriveNomCurrCT	577	
P5.2.2 ①	Motor Nom Speed 2	300	20000	rpm	Varies	578	
P5.2.3 ①	Motor PF 2	0.30	1.00		0.85	579	
P5.2.4 ①	Motor Nom Volt 2	180	690	V	Varies	580	
P5.2.5 ①	Motor Nom Freq 2	8.00	400.00	Hz	Varies	581	

Protections

Table 89. Motor — P6.1

Code	Parameter	Min.	Max.	Unit	Default	ID	Note
P6.1.1 ①②	Output Phase Fault				2	308	0 = No Action 1 = Warning 2 = Fault 3 = Fault, Coast
P6.1.2 ①②	Ground Fault				2	309	See Par ID 308
P6.1.3 ②	Ground Fault Limit	0	30	%	15	2158	
P6.1.4 ①②	Motor Thermal Protection				2	310	See Par ID 308
P6.1.5 ②	Motor Thermal F0 Current	0.0	150.0	%	40.0	311	
P6.1.6 ②	Motor Thermal Time	1	200	min	12	312	
P6.1.7 ①②	Stall Protection				0	313	See Par ID 308
P6.1.8 ②	Stall Current Limit	0.1	ActiveMotorNomCurr*2	A	ActiveMotorNomCurr*13/10	314	
P6.1.9 ②	Stall Time Limit	1.0	120.0	s	15.0	315	
P6.1.10 ②	Stall Frequency Limit	1.00	See Par ID 102	Hz	25.00	316	
P6.1.11 ①③	Underload Protection				0	317	See Par ID 308
P6.1.12 ②	Underload Fnom Torque	10.0	150.0	%	50.0	318	
P6.1.13 ②	Underload F0 Torque	5.0	150.0	%	10.0	319	
P6.1.14 ②	Underload Time Limit	2.00	600.00	s	20.00	320	

Note: ① Parameter value can only be changed after the drive has stopped.

② Parameter value will be set to be default when changing macros.

Chapter 6 — PID Application

Table 89. Motor — P6.1, continued

Code	Parameter	Min.	Max.	Unit	Default	ID	Note
P6.1.15 ①②	Thermistor Fault Response				2	333	See Par ID 308
P6.1.16 ①②	PT100 Fault Response				2	337	See Par ID 308
P6.1.17 ②	Preheat Mode				0	2159	See Par ID 1346
P6.1.18 ②	Preheat Control Source				31	2160	0 = DigIN:NormallyOpen 1 = DigIN:NormallyClose 2 = DigIN: 1 3 = DigIN: 2 4 = DigIN: 3 5 = DigIN: 4 6 = DigIN: 5 7 = DigIN: 6 8 = DigIN: 7 9 = DigIN: 8 10 = DigIN: A: IO1: 1 11 = DigIN: A: IO1: 2 12 = DigIN: A: IO1: 3 13 = DigIN: A: IO5: 1 14 = DigIN: A: IO5: 2 15 = DigIN: A: IO5: 3 16 = DigIN: A: IO5: 4 17 = DigIN: A: IO5: 5 18 = DigIN: A: IO5: 6 19 = DigIN: B: IO1: 1 20 = DigIN: B: IO1: 2 21 = DigIN: B: IO1: 3 22 = DigIN: B: IO5: 1 23 = DigIN: B: IO5: 2 24 = DigIN: B: IO5: 3 25 = DigIN: B: IO5: 4 26 = DigIN: B: IO5: 5 27 = DigIN: B: IO5: 6 28 = Time Channel 1 29 = Time Channel 2 30 = Time Channel 3 31 = Drive Temperature 32 = SlotA PT100 Temp Channel 1 33 = SlotA PT100 Temp Channel 2 34 = SlotA PT100 Temp Channel 3 35 = SlotA Max PT100 Temp 36 = SlotB PT100 Temp Channel 1 37 = SlotB PT100 Temp Channel 2 38 = SlotB PT100 Temp Channel 3 39 = SlotB Max PT100 Temp 40 = SlotA and SlotB Max PT100 Temp
P6.1.19 ②	Preheat Enter Temp	0.0	19.9	°C	10.0	2161	
P6.1.20 ②	Preheat Quit Temp	20.0	40.0	°C	20.0	2162	
P6.1.21 ②	Preheat Output Volt	0.0	20.0	%	2.0	2163	

Note: ① Parameter value can only be changed after the drive has stopped.

② Parameter value will be set to be default when changing macros.

Table 90. Drive — P6.2

Code	Parameter	Min.	Max.	Unit	Default	ID	Note
P6.2.1 ②	Line Start Lockout				2	750	0 = Disabled, No Change 1 = Enable, No Change 2 = Disabled, Changed 3 = Enable, Changed
P6.2.2 ②	Fault Reset Start				0	2483	0 = Start/Stop After Fault Reset 1 = Restart After Fault Reset
P6.2.3 ①②	4mA Input Fault				0	306	0 = No Action 1 = Warning 2 = Warning: Previous Freq 3 = Warning: Preset Freq 4 = Fault 5 = Fault, Coast
P6.2.4 ①②	4mA Fault Frequency	0.00	See Par ID 102	Hz	0.00	331	
P6.2.5 ①②	External Fault				2	307	See Par ID 308
P6.2.6 ①②	Input Phase Fault				2	332	See Par ID 308
P6.2.7 ①②	Uvolt Fault Response				2	330	See Par ID 308
P6.2.8 ①②	Unit Under Temp Prot				2	1564	See Par ID 308
P6.2.9 ①②	RTC Fault				1	955	See Par ID 308
P6.2.10 ①②	Replace Battery Fault Response				1	1256	See Par ID 308
P6.2.11 ①②	Replace Fan Fault Response				1	1257	See Par ID 308
P6.2.12 ②	Cold Weather Mode				0	2126	See Par ID 1346
P6.2.13 ②	Cold Weather Volt. Level	0.0	20.0	%	2.0	2127	
P6.2.14 ②	Cold Weather Time Out	0	10	min	3	2128	
P6.2.15	Cold Weather Password					2129	
P6.2.16	Under Temp Fault Override					2130	See Par ID 2118
P6.2.17 ②	STO Fault Response				2	2427	0 = No Action 1 = Warning 2 = Fault

Table 91. Communication — P6.3

Code	Parameter	Min.	Max.	Unit	Default	ID	Note
P6.3.1 ①②	Fieldbus Fault Response				2	334	0 = No Action 1 = Warning 2 = Fault 3 = Fault, Coast 4 = Warning, Coast
P6.3.2 ①②	OPTCard Fault Response				2	335	See Par ID 308
P6.3.3 ①②	IP Address Confliction Resp				1	1678	See Par ID 308
P6.3.4 ①②	Keypad Comm Fault Response				2	2157	See Par ID 308

Table 92. Auto Restart — P6.4

Code	Parameter	Min.	Max.	Unit	Default	ID	Note
P6.4.1 ②	AR Wait Time	1.00	300.00	s	1.00	321	
P6.4.2 ②	AR Trail Time	0.00	600.00	s	30.00	322	
P6.4.3 ②	AR Start Function				0	323	0 = Flying Start 1 = Ramp
P6.4.4 ②	Undervoltage Attempts	0	10		1	324	
P6.4.5 ②	OverVoltage Attempts	0	10		1	325	
P6.4.6 ②	OverCurrent Attempts	0	3		1	326	
P6.4.7 ②	4mA Fault Attempts	0	10		1	327	
P6.4.8 ②	Motor Temp Fault Attempts	0	10		1	329	
P6.4.9 ②	External Fault Attempts	0	10		0	328	
P6.4.10 ②	Underload Attempts	0	10		1	336	

Note: ① Parameter value can only be changed after the drive has stopped.

② Parameter value will be set to be default when changing macros.

PID Controller 1

Table 93. Basic Setting — P7.1

Code	Parameter	Min.	Max.	Unit	Default	ID	Note
P7.1.1 ②	PID1 Control Gain	0.00	200.00	%	100.00	1294	
P7.1.2 ②	PID1 Control ITime	0.00	600.00	s	1.00	1295	
P7.1.3 ②	PID1 Control DTime	0.00	100.00	s	0.00	1296	
P7.1.4 ①②	PID1 Process Unit				0	1297	0 = % 1 = 1/min 2 = rpm 3 = ppm 4 = pps 5 = l/s 6 = l/min 7 = l/h 8 = kg/s 9 = kg/min 10 = kg/h 11 = m3/s 12 = m3/min 13 = m3/h 14 = m/s 15 = mbar 16 = bar 17 = Pa 18 = kPa 19 = mVS 20 = kW 21 = °C 22 = GPM 23 = gal/s 24 = gal/min 25 = gal/h 26 = lb/s 27 = lb/min 28 = lb/h 29 = CFM 30 = ft3/s 31 = ft3/min 32 = ft3/h 33 = ft/s 34 = in wg 35 = ft wg 36 = PSI 37 = lb/in2 38 = HP 39 = °F 40 = PA 41 = WC 42 = HG 43 = ft 44 = m
P7.1.5 ②	PID1 Process Unit Min	-99999.99	See Par ID 1300	Varies	0.00	1298	
P7.1.6 ②	PID1 Process Unit Max	See Par ID 1298	99999.99	Varies	100.00	1300	
P7.1.7 ②	PID1 Process Unit Decimal	0	4		2	1302	
P7.1.8 ①②	PID1 Error Inversion				0	1303	See Par ID 181
P7.1.9 ②	PID1 Dead Band	0.00	99999.99	Varies	0.00	1304	
P7.1.10 ②	PID1 Dead Band Delay	0.00	320.00	s	0.00	1306	
P7.1.11 ②	PID1 Ramp Time	0.00	300.00	s	0.00	1311	

Note: ① Parameter value can only be changed after the drive has stopped.

② Parameter value will be set to be default when changing macros.

Table 94. Monitor — P7.2

Code	Parameter	Min.	Max.	Unit	Default	ID	Note
P7.2.1	FB PID1 Set Point 1	See Par ID 1298	See Par ID 1300	Varies		2542	
P7.2.2	FB PID1 Set Point 2	See Par ID 1298	See Par ID 1300	Varies		2544	
P7.2.3	FB PID1 Feedback 1			%		2550	
P7.2.4	FB PID1 Feedback 2			%		2551	
P7.2.5	FB PID1 Feedforward 1			%		2554	
P7.2.6	FB PID1 Feedforward 2			%		2555	

Setpoint

Table 95. Basic — P7.3.1

Code	Parameter	Min.	Max.	Unit	Default	ID	Note
P7.3.1.1 ②	PID1 Keypad Set Point 1	See Par ID 1298	See Par ID 1300	Varies	0.00	1307	
P7.3.1.2 ②	PID1 Keypad Set Point 2	See Par ID 1298	See Par ID 1300	Varies	0.00	1309	
P7.3.1.3 ②	PID1 Wake Up Action				0	2466	0 = Below Wake Up Level 1 = Above Wake Up Level 2 = Below Wake Up Level(PID ref.) Wake up when below wakeup level % set in Para ID 1318 or 1327 from PID Setpoint. 3 = Above Wake Up Level(PID ref.) Wake up when above wakeup level % set in Para ID 1318 or 1327 from PID Setpoint.

Table 96. Setpoint 1 — P7.3.2

Code	Parameter	Min.	Max.	Unit	Default	ID	Note
P7.3.2.1 ①②	PID1 Set Point 1 Source				1	1312	0 = Not Used 1 = PID1 Keypad Set Point 1 2 = PID1 Keypad Set Point 2 3 = AI1 4 = AI2 5 = Slot A: AI1 6 = Slot B: AI1 7 = FB Process Data Input 1 8 = FB Process Data Input 2 9 = FB Process Data Input 3 10 = FB Process Data Input 4 11 = FB Process Data Input 5 12 = FB Process Data Input 6 13 = FB Process Data Input 7 14 = FB Process Data Input 8 15 = PID2 Output 16 = FB PID1 Set Point 1 17 = FB PID1 Set Point 2
P7.3.2.2 ②	PID1 Set Point 1 Min	-200.00	200.00	%	0.00	1313	
P7.3.2.3 ②	PID1 Set Point 1 Max	-200.00	200.00	%	100.00	1314	
P7.3.2.4 ①②	PID1 Set Point 1 Sleep Enable				0	1315	See Par ID 1346
P7.3.2.5 ①②	PID1 Set Point 1 Sleep Unit Sel				0	2396	0 = Output Frequency 1 = Motor Speed 2 = Motor Current 3 = PID1 Feedback
P7.3.2.6 ②	PID1 Set Point 1 Sleep Level			Varies	0.00	2450	
P7.3.2.7 ②	PID1 Set Point 1 Sleep Delay	0	3000	s	0	1317	
P7.3.2.8 ②	PID1 Set Point 1 Wake Up Level	-99999.99	99999.99	Varies	0.00	1318	

Note: ① Parameter value can only be changed after the drive has stopped.

② Parameter value will be set to be default when changing macros.

Chapter 6 — PID Application

Table 96. Setpoint 1 — P7.3.2, continued

Code	Parameter	Min.	Max.	Unit	Default	ID	Note
P7.3.2.9 ②	PID1 Set Point 1 Boost	-2.0	2.0		1.0	1320	
P7.3.2.10 ②	PID1 Set Point 1 Comp Enable				0	1352	See Par ID 1346
P7.3.2.11 ②	PID1 Set Point 1 Comp Max	-200.00	200.00	%	0.00	1353	

Table 97. Setpoint 2 — P7.3.3

Code	Parameter	Min.	Max.	Unit	Default	ID	Note
P7.3.3.1 ①②	PID1 Set Point 2 Source				2	1321	See Par ID 1312
P7.3.3.2 ②	PID1 Set Point 2 Min	-200.00	200.00	%	0.00	1322	
P7.3.3.3 ②	PID1 Set Point 2 Max	-200.00	200.00	%	100.00	1323	
P7.3.3.4 ①②	PID1 Set Point 2 Sleep Enable				0	1324	See Par ID 1346
P7.3.3.5 ①②	PID1 Set Point 2 Sleep Unit Sel				0	2397	See Par ID 2396
P7.3.3.6 ②	PID1 Set Point 2 Sleep Level			Varies	0.00	2452	
P7.3.3.7 ②	PID1 Set Point 2 Sleep Delay	0	3000	s	0	1326	
P7.3.3.8 ②	PID1 Set Point 2 Wake Up Level	-99999.99	99999.99	Varies	0.00	1327	
P7.3.3.9 ②	PID1 Set Point 2 Boost	-2.0	2.0		1.0	1329	
P7.3.3.10 ②	PID1 Set Point 2 Comp Enable				0	1354	See Par ID 1346
P7.3.3.11 ②	PID1 Set Point 2 Comp Max	-200.00	200.00	%	0.00	1355	

Feedback

Table 98. Basic — P7.4.1

Code	Parameter	Min.	Max.	Unit	Default	ID	Note
P7.4.1.1 ①②	PID1 Feedback Function				0	1330	0 = Source 1 1 = SQRT(Source 1) 2 = SQRT(Source 1 - Source 2) 3 = SQRT(Source 1) + SQRT(Source 2) 4 = Source 1 + Source 2 5 = Source 1 - Source 2 6 = MIN(Source 1, Source 2) 7 = MAX(Source 1, Source 2) 8 = MEAN(Source1, Source2)
P7.4.1.2 ②	PID1 Feedback Gain	-1000.0	1000.0	%	100.0	1331	

Note: ① Parameter value can only be changed after the drive has stopped.
② Parameter value will be set to be default when changing macros.

Table 99. Feedback 1 — P7.4.2

Code	Parameter	Min.	Max.	Unit	Default	ID	Note
P7.4.2.1 ①②	PID1 Feedback 1 Source				2	1332	0 = Not Used 1 = AI1 2 = AI2 3 = Slot A: AI1 4 = Slot B: AI1 5 = FB Process Data Input 1 6 = FB Process Data Input 2 7 = FB Process Data Input 3 8 = FB Process Data Input 4 9 = FB Process Data Input 5 10 = FB Process Data Input 6 11 = FB Process Data Input 7 12 = FB Process Data Input 8 13 = PT100 Temperture 14 = PID2 Output 15 = SlotA PT100 Temp Channel 1 16 = SlotA PT100 Temp Channel 2 17 = SlotA PT100 Temp Channel 3 18 = SlotB PT100 Temp Channel 1 19 = SlotB PT100 Temp Channel 2 20 = SlotB PT100 Temp Channel 3 21 = FB PID1 Feedback 1 22 = FB PID1 Feedback 2
P7.4.2.2 ②	PID1 Feedback 1 Min	-200.00	200.00	%	0.00	1333	
P7.4.2.3 ②	PID1 Feedback 1 Max	-200.00	200.00	%	100.00	1334	

Table 100. Feedback 2 — P7.4.3

Code	Parameter	Min.	Max.	Unit	Default	ID	Note
P7.4.3.1 ①②	PID1 Feedback 2 Source				0	1335	See Par ID 1332
P7.4.3.2 ②	PID1 Feedback 2 Min	-200.00	200.00	%	0.00	1336	
P7.4.3.3 ②	PID1 Feedback 2 Max	-200.00	200.00	%	100.00	1337	

Feedforward

Table 101. Basic — P7.5.1

Code	Parameter	Min.	Max.	Unit	Default	ID	Note
P7.5.1.1 ①②	PID1 Feedforward Func				0	1338	See Par ID 1330
P7.5.1.2 ②	PID1 Feedforward Gain	-1000.0	1000.0	%	100.0	1339	

Note: ① Parameter value can only be changed after the drive has stopped.
② Parameter value will be set to be default when changing macros.

Chapter 6 — PID Application

Table 102. Feedforward 1 — P75.2

Code	Parameter	Min.	Max.	Unit	Default	ID	Note
P75.2.1 ①②	PID1 Feedforward 1 Source				0	1340	0 = Not Used 1 = AI1 2 = AI2 3 = Slot A: AI1 4 = Slot B: AI1 5 = FB Process Data Input 1 6 = FB Process Data Input 2 7 = FB Process Data Input 3 8 = FB Process Data Input 4 9 = FB Process Data Input 5 10 = FB Process Data Input 6 11 = FB Process Data Input 7 12 = FB Process Data Input 8 13 = PT100 Temperture 14 = PID2 Output 15 = SlotA PT100 Temp Channel 1 16 = SlotA PT100 Temp Channel 2 17 = SlotA PT100 Temp Channel 3 18 = SlotB PT100 Temp Channel 1 19 = SlotB PT100 Temp Channel 2 20 = SlotB PT100 Temp Channel 3 21 = FB PID1 Feedforward 1 22 = FB PID1 Feedforward 2
P75.2.2 ②	PID1 Feedforward 1 Min	-200.00	200.00	%	0.00	1341	
P75.2.3 ②	PID1 Feedforward 1 Max	-200.00	200.00	%	100.00	1342	

Table 103. Feedforward 2 — P75.3

Code	Parameter	Min.	Max.	Unit	Default	ID	Note
P75.3.1 ①②	PID1 Feedforward 2 Source				0	1343	See Par ID 1340
P75.3.2 ②	PID1 Feedforward 2 Min	-200.00	200.00	%	0.00	1344	
P75.3.3 ②	PID1 Feedforward 2 Max	-200.00	200.00	%	100.00	1345	

PID Controller 2

Table 104. Basic Setting — P8.1

Code	Parameter	Min.	Max.	Unit	Default	ID	Note
P8.1.1 ②	PID2 Control Gain	0.00	200.00	%	100.00	1356	
P8.1.2 ②	PID2 Control I Time	0.00	600.00	s	1.00	1357	
P8.1.3 ②	PID2 Control D Time	0.00	100.00	s	0.00	1358	
P8.1.4 ①②	PID2 Process Unit				0	1359	See Par ID 1297
P8.1.5 ②	PID2 Process Unit Min	-99999.99	See Par ID 1362	Varies	0.00	1360	
P8.1.6 ②	PID2 Process Unit Max	See Par ID 1360	99999.99	Varies	100.00	1362	
P8.1.7 ②	PID2 Process Unit Decimal	0	4		2	1364	
P8.1.8 ①②	PID2 Error Inversion				0	1365	See Par ID 181
P8.1.9 ②	PID2 Dead Band	0.00	99999.99	Varies	0.00	1366	
P8.1.10 ②	PID2 Dead Band Delay	0.00	320.00	s	0.00	1368	
P8.1.11 ②	PID2 Ramp Time	0.00	300.00	s	0.00	1373	

Note: ① Parameter value can only be changed after the drive has stopped.
② Parameter value will be set to be default when changing macros.

Table 105. Monitor — P8.2

Code	Parameter	Min.	Max.	Unit	Default	ID	Note
P8.2.1 ②	PID2 Wake Up Action				0	2467	See Par ID 2466
P8.2.2	FB PID2 Set Point 1	See Par ID 1298	See Par ID 1300	Varies		2546	
P8.2.3	FB PID2 Set Point 2	See Par ID 1298	See Par ID 1300	Varies		2548	
P8.2.4	FB PID2 Feedback 1			%		2552	
P8.2.5	FB PID2 Feedback 2			%		2553	
P8.2.6	FB PID2 Feedforward 1			%		2556	
P8.2.7	FB PID2 Feedforward 2			%		2557	

Setpoint

Table 106. Basic — P8.3.1

Code	Parameter	Min.	Max.	Unit	Default	ID	Note
P8.3.1.1 ②	PID2 Keypad Set Point 1	See Par ID 1360	See Par ID 1362	Varies	0.00	1369	
P8.3.1.2 ②	PID2 Keypad Set Point 2	See Par ID 1360	See Par ID 1362	Varies	0.00	1371	
P8.3.1.3 ②	PID2 Wake Up Action				0	2467	See Par ID 2466

Table 107. Setpoint 1 — P8.3.2

Code	Parameter	Min.	Max.	Unit	Default	ID	Note
P8.3.2.1 ①②	PID2 Set Point 1 Source				1	1374	0 = Not Used 1 = PID2 Keypad Set Point 1 2 = PID2 Keypad Set Point 2 3 = AI1 4 = AI2 5 = Slot A: AI1 6 = Slot B: AI1 7 = FB Process Data Input 1 8 = FB Process Data Input 2 9 = FB Process Data Input 3 10 = FB Process Data Input 4 11 = FB Process Data Input 5 12 = FB Process Data Input 6 13 = FB Process Data Input 7 14 = FB Process Data Input 8 15 = PID1 Output 16 = FB PID2 Set Point 1 17 = FB PID2 Set Point 2
P8.3.2.2 ②	PID2 Set Point 1 Min	-200.00	200.00	%	0.00	1375	
P8.3.2.3 ②	PID2 Set Point 1 Max	-200.00	200.00	%	100.00	1376	
P8.3.2.4 ①②	PID2 Set Point 1 Sleep Enable				0	1377	See Par ID 1346
P8.3.2.5 ①②	PID2 Set Point 1 Sleep Unit Sel				0	2398	0 = Output Frequency 1 = Motor Speed 2 = Motor Current 3 = PID2 Feedback
P8.3.2.6 ②	PID2 Set Point 1 Sleep Level			Varies	0.00	2454	
P8.3.2.7 ②	PID2 Set Point 1 Sleep Delay	0	3000	s	0	1379	
P8.3.2.8 ②	PID2 Set Point 1 WakeUp Level	-99999.99	99999.99	Varies	0.00	1380	
P8.3.2.9 ②	PID2 Set Point 1 Boost	-2.0	2.0		1.0	1382	
P8.3.2.10 ②	PID2 Set Point1 Comp Enable				0	1414	See Par ID 1346
P8.3.2.11 ②	PID2 Set Point1 Comp Max	-200.00	200.00	%	0.00	1415	
P8.3.2.12	FB PID2 Set Point 1	See Par ID 1298	See Par ID 1300	Varies		2546	

Note: ① Parameter value can only be changed after the drive has stopped.

② Parameter value will be set to be default when changing macros.

Chapter 6 — PID Application

Table 108. Setpoint 2 — P8.3.3

Code	Parameter	Min.	Max.	Unit	Default	ID	Note
P8.3.3.1 ①②	PID2 Set Point 2 Source				2	1383	See Par ID 1374
P8.3.3.2 ②	PID2 Set Point 2 Min	-200.00	200.00	%	0.00	1384	
P8.3.3.3 ②	PID2 Set Point 2 Max	-200.00	200.00	%	100.00	1385	
P8.3.3.4 ①②	PID2 Set Point 2 Sleep Enable				0	1386	See Par ID 1346
P8.3.3.5 ①②	PID2 Set Point 2 Sleep Unit Sel				0	2399	See Par ID 2398
P8.3.3.6 ②	PID2 Set Point 2 Sleep Level			Varies	0.00	2456	
P8.3.3.7 ②	PID2 Set Point 2 Sleep Delay	0	3000	s	0	1388	
P8.3.3.8 ②	PID2 Set Point 2 WakeUp Level	-99999.99	99999.99	Varies	0.00	1389	
P8.3.3.9 ②	PID2 Set Point 2 Boost	-2.0	2.0		1.0	1391	
P8.3.3.10 ②	PID2 Set Point 2 Comp Enable				0	1416	See Par ID 1346
P8.3.3.11 ②	PID2 Set Point 2 Comp Max	-200.00	200.00	%	0.00	1417	
P8.3.3.12	FB PID2 Set Point 2	See Par ID 1298	See Par ID 1300	Varies		2548	

Feedback

Table 109. Basic — P8.4.1

Code	Parameter	Min.	Max.	Unit	Default	ID	Note
P8.4.1.1 ①②	PID2 Feedback Func				0	1392	See Par ID 1330
P8.4.1.2 ②	PID2 Feedback Gain	-1000.0	1000.0	%	100.0	1393	

Table 110. Feedback 1 — P8.4.2

Code	Parameter	Min.	Max.	Unit	Default	ID	Note
P8.4.2.1 ①②	PID2 Feedback 1 Source				2	1394	0 = Not Used 1 = AI1 2 = AI2 3 = Slot A: AI1 4 = Slot B: AI1 5 = FB Process Data Input 1 6 = FB Process Data Input 2 7 = FB Process Data Input 3 8 = FB Process Data Input 4 9 = FB Process Data Input 5 10 = FB Process Data Input 6 11 = FB Process Data Input 7 12 = FB Process Data Input 8 13 = PT100 Temperature 14 = PID1 Output 15 = SlotA PT100 Temp Channel 1 16 = SlotA PT100 Temp Channel 2 17 = SlotA PT100 Temp Channel 3 18 = SlotB PT100 Temp Channel 1 19 = SlotB PT100 Temp Channel 2 20 = SlotB PT100 Temp Channel 3 21 = FB PID2 Feedback 1 22 = FB PID2 Feedback 2
P8.4.2.2 ②	PID2 Feedback 1 Min	-200.00	200.00	%	0.00	1395	
P8.4.2.3 ②	PID2 Feedback 1 Max	-200.00	200.00	%	100.00	1396	
P8.4.2.4	FB PID2 Feedback 1			%		2552	

Note: ① Parameter value can only be changed after the drive has stopped.
② Parameter value will be set to be default when changing macros.

Table 111. Feedback 2 — P8.4.3

Code	Parameter	Min.	Max.	Unit	Default	ID	Note
P8.4.3.1 ①②	PID2 Feedback 2 Source				0	1397	See Par ID 1394
P8.4.3.2 ②	PID2 Feedback 2 Min	-200.00	200.00	%	0.00	1398	
P8.4.3.3 ②	PID2 Feedback 2 Max	-200.00	200.00	%	100.00	1399	
P8.4.3.4	FB PID2 Feedback 2			%		2553	

Feedforward

Table 112. Basic — P8.5.1

Code	Parameter	Min.	Max.	Unit	Default	ID	Note
P8.5.1.1 ①②	PID2 Feedforward Func				0	1400	See Par ID 1330
P8.5.1.2 ②	PID2 Feedforward Gain	-1000.0	1000.0	%	100.0	1401	

Table 113. Feedforward 1 — P8.5.2

Code	Parameter	Min.	Max.	Unit	Default	ID	Note
P8.5.2.1 ①②	PID2 Feedforward 1 Source				0	1402	0 = Not Used 1 = AI1 2 = AI2 3 = Slot A: AI1 4 = Slot B: AI1 5 = FB Process Data Input 1 6 = FB Process Data Input 2 7 = FB Process Data Input 3 8 = FB Process Data Input 4 9 = FB Process Data Input 5 10 = FB Process Data Input 6 11 = FB Process Data Input 7 12 = FB Process Data Input 8 13 = PT100 Temperture 14 = PID1 Output 15 = SlotA PT100 Temp Channel 1 16 = SlotA PT100 Temp Channel 2 17 = SlotA PT100 Temp Channel 3 18 = SlotB PT100 Temp Channel 1 19 = SlotB PT100 Temp Channel 2 20 = SlotB PT100 Temp Channel 3 21 = FB PID2 Feedforward 1 22 = FB PID2 Feedforward 2
P8.5.2.2 ②	PID2 Feedforward 1 Min	-200.00	200.00	%	0.00	1403	
P8.5.2.3 ②	PID2 Feedforward 1 Max	-200.00	200.00	%	100.00	1404	
P8.5.2.4	FB PID2 Feedforward 1			%		2556	

Table 114. Feedforward 2 — P8.5.3

Code	Parameter	Min.	Max.	Unit	Default	ID	Note
P8.5.3.1 ①②	PID2 Feedforward 2 Source				0	1405	See Par ID 1402
P8.5.3.2 ②	PID2 Feedforward 2 Min	-200.00	200.00	%	0.00	1406	
P8.5.3.3 ②	PID2 Feedforward 2 Max	-200.00	200.00	%	100.00	1407	
P8.5.3.4	FB PID2 Feedforward 2			%		2557	

Note: ① Parameter value can only be changed after the drive has stopped.
② Parameter value will be set to be default when changing macros.

Chapter 6 — PID Application

Table 115. Fire Mode — P9

Code	Parameter	Min.	Max.	Unit	Default	ID	Note
P9.1 ①②	Fire Mode Function				0	535	0 = Closing Contact 1 = Opening Contact
P9.2 ①②	Fire Mode Ref Select Function				0	536	0 = Fire Mode Min Frequency 1 = Fire Mode Ref 2 = Fieldbus Ref 3 = AI1 4 = AI2 5 = AI1 + AI2 6 = PID1 Control Output 7 = PID2 Control Output
P9.3 ③	Fire Mode Min Frequency	See Par ID 101	See Par ID 102	Hz	15.00	537	
P9.4 ③	Fire Mode Freq Ref 1	0.0	100.0	%	75.0	565	
P9.5 ③	Fire Mode Freq Ref 2	0.0	100.0	%	100.0	564	
P9.6	Fire Mode Test Enable					2443	See Par ID 1346
P9.7 ①②	Smoke Purge Frequency	0.0	100.0	%	50.0	554	

Bypass

Table 116. Basic Setting — P10.1

Code	Parameter	Min.	Max.	Unit	Default	ID	Note
P10.1.1 ①②	Bypass Enable				1	1418	See Par ID 1346
P10.1.2 ①②	Bypass Start Delay	1	32765	s	1	544	
P10.1.3 ①②	Auto Bypass				1	542	See Par ID 1346
P10.1.4 ①②	Auto Bypass Delay	0	32765	s	10	543	
P10.1.5 ①②	OverCurrent Bypass Enable				1	547	See Par ID 1346
P10.1.6 ①②	IGBT Fault Bypass Enable				1	546	See Par ID 1346
P10.1.7 ①②	4mA Fault Bypass Enable				1	548	See Par ID 1346
P10.1.8 ①②	UnderVoltage Bypass Enable				1	545	See Par ID 1346
P10.1.9 ①②	OverVoltage Bypass Enable				1	549	See Par ID 1346
P10.1.10 ①②	Motor OverTemp Bypass Enable				1	1698	See Par ID 1346
P10.1.11 ①②	UnderLoad Bypass Enable				1	1699	See Par ID 1346
P10.1.12 ①②	External Bypass Enable				1	1700	See Par ID 1346
P10.1.13 ①②	Charge Switch Fault Bypass Enable				1	1701	See Par ID 1346
P10.1.14 ①②	Saturation Trip Fault Bypass Enable				1	1702	See Par ID 1346
P10.1.15 ①②	Under Temp Fault Bypass Enable				1	1703	See Par ID 1346
P10.1.16 ①②	EEPROM Fault Bypass Enable				1	1704	See Par ID 1346
P10.1.17 ①②	FRAM Fault Bypass Enable				1	1705	See Par ID 1346
P10.1.18 ①②	Watchdog Fault Bypass Enable				1	1706	See Par ID 1346
P10.1.19 ①②	Fan Cooling Fault Bypass Enable				1	1707	See Par ID 1346
P10.1.20 ①②	Keypad Com Fault Bypass Enable				1	1708	See Par ID 1346
P10.1.21 ①②	Option Card Fault Bypass Enable				1	1709	See Par ID 1346
P10.1.22 ①②	RTC Clock Fault Bypass Enable				1	1710	See Par ID 1346
P10.1.23 ①②	Ctrl Board OverTemp Fault Bypass Enable				1	1711	See Par ID 1346
P10.1.24 ①②	Speed Search Start Fault Bypass Enable				1	1712	See Par ID 1346
P10.1.25 ①②	Fieldbus Fault Bypass Enable				1	1713	See Par ID 1346

Note: ① Parameter value can only be changed after the drive has stopped.
② Parameter value will be set to be default when changing macros.

Table 117. Redundant Drive — P10.2

Code	Parameter	Min.	Max.	Unit	Default	ID	Note
P10.2.1 ①②	Redundant Drive Enable				0	2476	See Par ID 1346
P10.2.2 ①②	Drive ID	0	5		0	2278	
P10.2.3 ②	Redundant Run Time Enable				0	2477	See Par ID 1346
P10.2.4	Redundant Run Time Reset					2478	See Par ID 2125
P10.2.5 ②	Redundant RunTime Limit	0.0	300000.0	h	0.0	2479	

Real Time Clock

Table 118. Interval 1 — P11.1

Code	Parameter	Min.	Max.	Unit	Default	ID	Note
P11.1.1 ②	Interval 1 Setting				0	2487	0 = Weekly 1 = Daily
P11.1.2 ②	Interval 1 On Time				0	491	
P11.1.3 ②	Interval 1 Off Time				0	493	
P11.1.4 ②	Interval 1 From Day				0	517	0 = Sunday 1 = Monday 2 = Tuesday 3 = Wednesday 4 = Thursday 5 = Friday 6 = Saturday
P11.1.5 ②	Interval 1 To Day				0	518	See Par ID 517
P11.1.6 ②	Interval 1 Channel				0	519	0 = Not Used 1 = Time Channel 1 2 = Time Channel 2 3 = Time Channel 3

Table 119. Interval 2 — P11.2

Code	Parameter	Min.	Max.	Unit	Default	ID	Note
P11.2.1 ②	Interval 2 Setting				0	2488	See Par ID 2487
P11.2.2 ②	Interval 2 On Time				0	495	
P11.2.3 ②	Interval 2 Off Time				0	497	
P11.2.4 ②	Interval 2 From Day				0	520	See Par ID 517
P11.2.5 ②	Interval 2 To Day				0	521	See Par ID 517
P11.2.6 ②	Interval 2 Channel				0	522	See Par ID 519

Table 120. Interval 3 — P11.3

Code	Parameter	Min.	Max.	Unit	Default	ID	Note
P11.3.1 ②	Interval 3 Setting				0	2489	See Par ID 2487
P11.3.2 ②	Interval 3 On Time				0	499	
P11.3.3 ②	Interval 3 Off Time				0	501	
P11.3.4 ②	Interval 3 From Day				0	523	See Par ID 517
P11.3.5 ②	Interval 3 To Day				0	524	See Par ID 517
P11.3.6 ②	Interval 3 Channel				0	525	See Par ID 519

Note: ① Parameter value can only be changed after the drive has stopped.
 ② Parameter value will be set to be default when changing macros.

Chapter 6 — PID Application

Table 121. Interval 4 — P11.4

Code	Parameter	Min.	Max.	Unit	Default	ID	Note
P11.4.1 ②	Interval 4 Setting				0	2490	See Par ID 2487
P11.4.2 ②	Interval 4 On Time				0	503	
P11.4.3 ②	Interval 4 Off Time				0	505	
P11.4.4 ②	Interval 4 From Day				0	526	See Par ID 517
P11.4.5 ②	Interval 4 To Day				0	527	See Par ID 517
P11.4.6 ②	Interval 4 Channel				0	528	See Par ID 519

Table 122. Interval 5 — P11.5

Code	Parameter	Min.	Max.	Unit	Default	ID	Note
P11.5.1 ②	Interval 5 Setting				0	2491	See Par ID 2487
P11.5.2 ②	Interval 5 On Time				0	507	
P11.5.3 ②	Interval 5 Off Time				0	509	
P11.5.4 ②	Interval 5 From Day				0	529	See Par ID 517
P11.5.5 ②	Interval 5 To Day				0	530	See Par ID 517
P11.5.6 ②	Interval 5 Channel				0	531	See Par ID 519

Table 123. Timer — P11.6

Code	Parameter	Min.	Max.	Unit	Default	ID	Note
P11.6.1 ②	Timer 1 Duration	0	72000	s	0	511	
P11.6.2 ②	Timer 1 Channel				0	532	See Par ID 519
P11.6.3 ②	Timer 2 Duration	0	72000	s	0	513	
P11.6.4 ②	Timer 2 Channel				0	533	See Par ID 519
P11.6.5 ②	Timer 3 Duration	0	72000	s	0	515	
P11.6.6 ②	Timer 3 Channel				0	534	See Par ID 519

Communication

Table 124. FB Process Data Input Sel — P12.1

Code	Parameter	Min.	Max.	Unit	Default	ID	Note
P12.1.1 ②	FB Process Data Input 1 Sel	0	2560		0	2533	
P12.1.2 ②	FB Process Data Input 2 Sel	0	2560		2542	2534	
P12.1.3 ②	FB Process Data Input 3 Sel	0	2560		2550	2535	
P12.1.4 ②	FB Process Data Input 4 Sel	0	2560		103	2536	
P12.1.5 ②	FB Process Data Input 5 Sel	0	2560		104	2537	
P12.1.6 ②	FB Process Data Input 6 Sel	0	2560		107	2538	
P12.1.7 ②	FB Process Data Input 7 Sel	0	2560		0	2539	
P12.1.8 ②	FB Process Data Input 8 Sel	0	2560		0	2540	

Note: ② Parameter value will be set to be default when changing macros.

Table 125. FB Process Data Output Sel — P12.2

Code	Parameter	Min.	Max.	Unit	Default	ID	Note
P12.2.1 ②	FB Process Data Output 1 Sel				1	1556	
P12.2.2 ②	FB Process Data Output 2 Sel				2	1557	
P12.2.3 ②	FB Process Data Output 3 Sel				3	1558	
P12.2.4 ②	FB Process Data Output 4 Sel				4	1559	
P12.2.5 ②	FB Process Data Output 5 Sel				5	1560	
P12.2.6 ②	FB Process Data Output 6 Sel				6	1561	
P12.2.7 ②	FB Process Data Output 7 Sel				7	1562	
P12.2.8 ②	FB Process Data Output 8 Sel				28	1563	
P12.2.9 ②	Standard Status Word Bit0 Function Select				1	2415	0 = Not Used 1 = Ready 2 = Run 3 = Fault 4 = Fault Invert 5 = Warning 6 = Reversed 7 = At Speed 8 = Zero Frequency 9 = Freq Limit 1 Superv 10 = Freq Limit 2 Superv 11 = PID1 Superv 12 = PID2 Superv 13 = OverHeat Fault 14 = OverCurrent Regular 15 = OverVoltage Regular 16 = UnderVoltage Regular 17 = 4mA Ref Fault/Warning 20 = Torq Limit Superv 21 = Ref Limit Superv 22 = Control from I/O 23 = Un-Requested Rotation Direction 24 = Thermistor Fault Output 25 = Fire Mode 26 = In Bypass Mode 27 = Ext Fault/Warning 28 = Auto Control 29 = Jog Speed Select 30 = Motor Therm Protection 31 = FB Digital Input 1 32 = FB Digital Input 2 33 = FB Digital Input 3 34 = FB Digital Input 4 35 = Damper Control 36 = TC1 Status 37 = TC2 Status 38 = TC3 Status 40 = Power Limit Superv 41 = Temp Limit Superv 42 = Analog Input Superv 43 = Motor 1 Control 48 = Logic Fulfilled 49 = PID1 Sleep 50 = PID2 Sleep 51 = Motor Current 1 Supv 52 = Motor Current 2 Supv 53 = Second AI Limit Supv 54 = DC Charge Switch Close 55 = Preheat Active 56 = Cold Weather Active 58 = 2th Stage Ramp Frequency Active 59 = STO Fault Output 60 = Run Bypass/Drive 61 = Bypass Overload 62 = Bypass Run

Note: ② Parameter value will be set to be default when changing macros.

Chapter 6 — PID Application

Table 125. FB Process Data Output Sel — P12.2, continued

Code	Parameter	Min.	Max.	Unit	Default	ID	Note
P12.2.10 ②	Standard Status Word Bit1 Function Select				2	2416	See Par ID 2415
P12.2.11 ②	Standard Status Word Bit2 Function Select				3	2417	See Par ID 2415
P12.2.12 ②	Standard Status Word Bit3 Function Select				4	2418	See Par ID 2415
P12.2.13 ②	Standard Status Word Bit4 Function Select				5	2419	See Par ID 2415
P12.2.14 ②	Standard Status Word Bit5 Function Select				6	2420	See Par ID 2415
P12.2.15 ②	Standard Status Word Bit6 Function Select				7	2421	See Par ID 2415
P12.2.16 ②	Standard Status Word Bit7 Function Select				8	2422	See Par ID 2415

RS485 Bus

Table 126. Basic Setting — P12.3.1

Code	Parameter	Min.	Max.	Unit	Default	ID	Note
P12.3.1.1 ①	RS485 Comm Set				0	586	0 = Modbus RTU 1 = BACnet MS/TP 2 = SA Bus

Table 127. Modbus RTU — P12.3.2

Code	Parameter	Min.	Max.	Unit	Default	ID	Note
P12.3.2.1 ①	Slave Address	1	247		1	587	
P12.3.2.2 ①	Baud Rate				1	584	0 = 9600 1 = 19200 2 = 38400 3 = 57600 4 = 115200
P12.3.2.3 ①	Parity Type				2	585	0 = None 1 = Odd 2 = Even
P12.3.2.4	Modbus RTU Protocol Status					588	0 = Initial 1 = Stopped 2 = Operational 3 = Faulted
P12.3.2.5	Comm Timeout Modbus RTU	0	60000	ms	10000	593	
P12.3.2.6	Modbus RTU Fault Response				0	2516	0 = in Fieldbus Control 1 = in all Control

Note: ① Parameter value can only be changed after the drive has stopped.

② Parameter value will be set to be default when changing macros.

Table 128. BACnet MS/TP — P12.3.3

Code	Parameter	Min.	Max.	Unit	Default	ID	Note
P12.3.3.1 ①	MSTP Baud Rate				2	594	0 = 9600 1 = 19200 2 = 38400 3 = 76800 4 = 115200
P12.3.3.2 ①	MSTP Device Address	0	127		1	595	
P12.3.3.3 ①	MSTP Instance Number	0	4194302		Varies	596	
P12.3.3.4	MSTP Comm Timeout	0	60000	ms	10000	598	
P12.3.3.5	MSTP Protocol Status					599	0 = Stopped 1 = Operational 2 = Faulted
P12.3.3.6	MSTP Fault Code					600	0 = None 1 = Sole Master
P12.3.3.7 ②	MSTP Fault Response				0	2526	See Par ID 2516
P12.3.3.8 ①	MSTP Max Master				127	1537	

EtherNet Bus

Table 129. Basic Setting — P12.4.1

Code	Parameter	Min.	Max.	Unit	Default	ID	Note
P12.4.1.1 ①	IP Address Mode				1	1500	0 = Static IP 1 = DHCP with AutoIP
P12.4.1.2	Active IP Address					1507	
P12.4.1.3	Active Subnet Mask					1509	
P12.4.1.4	Active Default Gateway					1511	
P12.4.1.5	MAC Address					1513	
P12.4.1.6 ①	Static IP Address				192.168.1.254	1501	
P12.4.1.7 ①	Static Subnet Mask				255.255.255.0	1503	
P12.4.1.8 ①	Static Default Gateway				192.168.1.1	1505	
P12.4.1.9 ①	Enable BACnetIP				0	1725	See Par ID 1346

Table 130. Modbus TCP — P12.4.2

Code	Parameter	Min.	Max.	Unit	Default	ID	Note
P12.4.2.1	Connection Limit				5	609	
P12.4.2.2	Modbus TCP Unit ID				1	610	
P12.4.2.3	Comm Timeout Modbus TCP	0	60000	ms	10000	611	
P12.4.2.4	Modbus TCP Protocol Status					612	See Par ID 599
P12.4.2.5	Modbus TCP Fault Response				0	2517	See Par ID 2516

Note: ① Parameter value can only be changed after the drive has stopped.

② Parameter value will be set to be default when changing macros.

Chapter 6 — PID Application

Table 131. BACnet IP — P12.4.3

Code	Parameter	Min.	Max.	Unit	Default	ID	Note
P12.4.3.1 ①②	BACnet IP UDP port number				47808	1733	47808 = BAC0 47809 = BAC1 47810 = BAC2 47811 = BAC3 47812 = BAC4 47813 = BAC5 47814 = BAC6 47815 = BAC7 47816 = BAC8 47817 = BAC9 47818 = BACA 47819 = BACB 47820 = BACC 47821 = BACD 47822 = BACE 47823 = BACF
P12.4.3.2 ②	BACnet IP Foreign Device				0	1734	See Par ID 1346
P12.4.3.3 ②	BACnet IP BBMD IP				0.0.0.0	1735	
P12.4.3.4 ②	BACnet IP BBMD Port				47808	1737	See Par ID 1733
P12.4.3.5 ②	BACnet IP Registration Interval	0	65535		10	1738	
P12.4.3.6 ②	BACnet IP Comm Timeout	0	60000		0	1739	
P12.4.3.7	BACnet IP Protocol Status					1740	See Par ID 599
P12.4.3.8 ②	BACnet IP Fault Behavior				0	1741	See Par ID 2516
P12.4.3.9 ①	BACnetIP Instance Number	0	4194302		Varies	1742	

System

Table 132. Basic Setting — P13.1

Code	Parameter	Min.	Max.	Unit	Default	ID	Note
P13.1.1	Language				0	340	0 = English 1 = 中文 2 = Deutsch
P13.1.2 ①	Application					142	0 = Basic 1 = PID 2 = Advanced
P13.1.3 ①	Parameter Sets					619	0 = No 1 = Reload Defaults 2 = Reload Set 1 3 = Reload Set 2 4 = Store Set 1 5 = Store Set 2 6 = Reset 7 = Reload Defaults VM
P13.1.4	Up To Keypad					620	See Par ID 2118
P13.1.5 ①	Down From Keypad					621	0 = No 1 = All Parameters 2 = All, No Motor 3 = App Parameters

Note: ① Parameter value can only be changed after the drive has stopped.
② Parameter value will be set to be default when changing macros.

Table 132. Basic Setting — P13.1, continued

Code	Parameter	Min.	Max.	Unit	Default	ID	Note
P13.1.6	Parameter Comparison					623	0 = No 1 = Compare with Keypad 2 = Compare with Default 3 = Compare with Set 1 4 = Compare with Set 2
P13.1.7	Password	0	9999		0	624	
P13.1.8	Parameter Lock				0	625	0 = Change Enable 1 = Change Disable
P13.1.9	Multimonitor Set				0	627	See Par ID 625
P13.1.10	Default Page				0	628	0 = None 1 = Main Menu 2 = Multi-Monitor 3 = Favorite Menu 4 = Keypad Reference
P13.1.11	Timeout Time	0	65535	s	30	629	
P13.1.12	Contrast Adjust	5	18		12	630	
P13.1.13	Backlight Time	1	65535	min	10	631	
P13.1.14	Fan Control				2	632	0 = Continuous 1 = Temperature 2 = Run Follow 3 = Calculate IGBT Temp
P13.1.15	Keypad ACK Timeout	200	5000	ms	200	633	
P13.1.16	Keypad Retry Number	1	10		5	634	
P13.1.17	Startup Wizard				0	626	0 = Yes 1 = No
P13.1.18 ②	Jog Softkey Hidden				0	2412	See Par ID 1346
P13.1.19 ②	Reverse Softkey Hidden				0	2413	See Par ID 1346

Note: ② Parameter value will be set to be default when changing macros.

Chapter 6 — PID Application

Table 132. Basic Setting — P13.1, continued

Code	Parameter	Min.	Max.	Unit	Default	ID	Note
P13.1.20 ©	Output Display Unit				45	2424	0 = % 1 = 1/min 2 = rpm 3 = ppm 4 = pps 5 = l/s 6 = l/min 7 = l/h 8 = kg/s 9 = kg/min 10 = kg/h 11 = m3/s 12 = m3/min 13 = m3/h 14 = m/s 15 = mbar 16 = bar 17 = Pa 18 = kPa 19 = mVS 20 = kW 21 = °C 22 = GPM 23 = gal/s 24 = gal/min 25 = gal/h 26 = lb/s 27 = lb/min 28 = lb/h 29 = CFM 30 = ft3/s 31 = ft3/min 32 = ft3/h 33 = ft/s 34 = in wg 35 = ft wg 36 = PSI 37 = lb/in2 38 = HP 39 = °F 40 = PA 41 = WC 42 = HG 43 = ft 44 = m 45 = Hz 46 = strokes/min
P13.1.21 ©	Output Display Unit Min	-60000.00	See Par ID 2425	Varies	0.00	2460	
P13.1.22 ©	Output Display Unit Max	See Par ID 2460	60000.00	Varies	Varies	2425	

Table 133. Version Info — P13.2

Code	Parameter	Min.	Max.	Unit	Default	ID	Note
P13.2.1	Keypad Software Version					640	
P13.2.2	Motor Control Software Version					642	
P13.2.3	Application Software Version					644	
P13.2.4	Software Bundle Version					1714	

Note: © Parameter value will be set to be default when changing macros.

Table 134. Application Info — P13.3

Code	Parameter	Min.	Max.	Unit	Default	ID	Note
P13.3.1	Brake Chopper					646	See Par ID 2118
P13.3.2	Brake Resistor Status					647	See Par ID 2118
P13.3.3	Serial Number					648	

Table 135. User Info — P13.4

Code	Parameter	Min.	Max.	Unit	Default	ID	Note
P13.4.1	Real Time Clock				0.0.0.1:1:13	566	
P13.4.2	Daylight Saving				0	582	0 = Off 1 = EU 2 = US
P13.4.3	Total MWh Count			Mwh		601	
P13.4.4	Total Power Day Count					603	
P13.4.5	Total Power Hr Count					606	
P13.4.6	Trip MWh Count			Mwh		604	
P13.4.7	Clear Trip MWh Count					635	See Par ID 2125
P13.4.8	Trip Power Day Count					636	
P13.4.9	Trip Power Hr Count					637	
P13.4.10	Clear Trip Power Count					639	See Par ID 2125

Table 136. Operate Mode — O

Code	Parameter	Min.	Max.	Unit	Default	ID	Note
O1	Output Frequency			Hz		1	
O2	Freq Reference			Hz		24	
O3	Motor Speed			rpm		2	
O4	Motor Current			A		3	
O5	Motor Torque			%		4	
O6	Motor Power			%		5	
O7	Motor Voltage			V		6	
O8	DC-link Voltage			V		7	
O9	Unit Temperature			°C		8	
O10	Motor Temperature			%		9	
R11 ②	Keypad Reference	See Par ID 101	See Par ID 102	Hz	0.00	141	
R12 ②	PID1 Keypad Set Point 1	See Par ID 1298	See Par ID 1300	Varies	0.00	1307	
R13 ②	PID1 Keypad Set Point 2	See Par ID 1298	See Par ID 1300	Varies	0.00	1309	

Note: ② Parameter value will be set to be default when changing macros.

Chapter 7—Advanced application parameter

The Advanced Application is designed for a large subset of applications in the HVAC industry. It includes some advanced timer and logic control to operate in addition to the Basic and PID applications functions listed earlier. It is designed to make use of the standard HOA control along with the control operations that would be used in advanced setups. Below is a list of features that is available.

Advanced Application includes functions:

- Bypass Control
- Fire Mode
- Damper Control
- Pre heat/cold weather mode
- Hand/Off/Auto in individual button for easy change of control mode.
- Damper Control
- Programmable Protections
- Programmable digital/analog input/output function
- Programmable start/stop signal logic
- Voltage and Current limiters
- Energy Savings Calculator
- Two independent set of Acceleration/Deceleration ramps
- Skip frequency
- Start source (Local/Remote control function)
- Reference source
- Flying start
- Volts per Hertz control programmable
- Real time clock—RTC time display
- RTC Timers and Interval control
- Auto restart on fault to drive or bypass
- Programmable switching frequency
- Multi-Preset speeds
- Fan control
- Joystick Control
- Logic Functions
- Bumpless transition between Hand and Auto
- Drooping

I/O Controls

• Terminal To Function (TTF) Programming

The design behind the programming of the digital inputs in the VS3 drive is to use “Terminal To Function” programming, which is composed of multiple functions that get assigned a digital input to that function. The parameters in the drive are set up with specific functions and by defining the digital input and slot in some cases, depending on which options are available. For use of the drives control board inputs, they will be referred to as DigIN:1 through DigIN:8. When additional option cards are used, they will be defined as DigIN:X:IOY:Z. The X indicates the slot that the card is being installed in, which will be either A or B. The IOY determines the type of card it is, which would be IO1 or IO5. The Z indicates which input is being used on that available option card.

• Function To Terminal (FTT) Programming

The design behind the programming of the relay outputs and digital output in the VS3 drive is to use “Function To Terminal” programming. It is composed of a terminal, be it a relay output or a digital output, that is assigned a parameter. Within that parameter, it has different functions that can be set. The parameters of the Standard Application are explained in Appendix A of this manual, “Description of Parameters.” The explanations are arranged according to the parameter number. For the DI function, we use Terminal programming method to function (TTF), where there is a fixed input that gets programmed to a list of functions. This allows for multiple inputs to be used for different functions. Connecting a certain input with a certain parameter function is done by give a parameter an appropriate value. The value is formed by the location of the input, either being on the standard control board or an external option board and the slot it is located in.

Force open/force close selection

The Force Open Selection would make the selected function always off. Essentially this is a virtual switch that is always open. The Force Close Selection would make the selected function always on. Essentially this is a virtual switch that is always closed. These options are assigned to a function if we want to force a state without using a hardware input. The standard options are DigIn: Force Open - indication that the parameter function is always going to be open, that being said depending on the logic of the function this could mean the function is always not active or always active. When the selection of a function is DigIn: Force Closed - indication that the parameter function is always going to be closed, that being said again depending on the location of the function this could mean the function is always active or not active. Examples of these options would be ID190 Start Signal 1, when set to “Force Open” and the drive is looking at I/O terminals for control, in this case the drive would never start since this Function is always Open. If this function is set to “Force closed” the drive would always be in a start mode when in that control location.

Example:

If we set Run Enable to Force Closed the drive is always enabled. If we set the same function to Force Open the drive would never be Enabled. If a Digital input is to be used to activate this Run Enable the function should be assigned to a hardware input(See below for DIGIN Selections).

DIGIN selection

This allows Assignment of a hardware digital input to a function, this is set in a format of DigIn:X where X is one of the 8 Digital inputs on the Main control board.

Example:

If we set Run Enable to DigIn:6 the drive will be enabled when digital input 6 (Terminal 8) is closed, and would not be enabled when digital input 6 (Terminal 8) is open.

Option board digIn selection

This allows Assignment of a hardware digital input on an option card to a function, this is set in a format of DigIn: Y:IO1:X where Y is the slot the option card is inserted on the Main control board and X is the Input on the Board and IO1 is the type of option board used.

Example:

If we set Run Enable to DigIn:A:IO5:6 the drive will be enabled when digital input 6 is closed on the IO5 option card which is inserted in Slot A, and would not be enabled when digital input 6 on the option card is open.

Timer channel selection

A Time Channel is a virtual path to link the digital output of a timer function to a digital input function. To utilize this feature a timer or interval would need to be assigned to a time channel 1 through 3, and the input function to be controlled would need to be assigned to the same time channel.

Example:

If we set Run Enable to DigIn:TimeChannel1 the drive will be enabled when the timer assigned to Time Channel 1 is active or High, and would not be enabled when the Time Channel is inactive or Low.

Control I/O configuration

- Run 240 Vac and 24 Vdc control wiring in separate conduit
- Communication wire to be shielded

Table 137. Advanced Application Default I/O Configuration

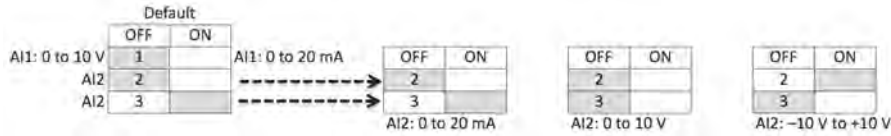

External Wiring	Pin	Signal Name	Signal	Default Setting	Description
	1	+10V	Ref. Output Voltage	-	10VDC Supply Source
	2	AI1+ ①	Analog Input 1	0-10V	Voltage Speed Reference (Programmable to 4-20mA)
	3	AI1-	Analog Input 1 Ground	-	Analog Input 1 Common (Ground)
	4	AI2+ ①	Analog Input 2	4-20mA	Current Speed Reference (Programmable to 0-10V)
	5	AI2-	Analog Input 2 Ground	-	Analog Input 2 Common (Ground)
	6	GND	I/O Signal Ground	-	I/O Ground for Reference and Control
	7	DIN5	Digital Input 5	Preset Speed B0	Sets frequency output to Preset Speed 1
	8	DIN6	Digital Input 6	Fire Mode	Enables drive into Fire Mode
	9	DIN7	Digital Input 7\TI+	Bypass Start	Enables drive into Bypass mode waiting for drive start
	10	DIN8	Digital Input 8\TI-	Force Auto	Input forces drive into Auto Control place
	11	CMB	DI5 to DI8 Common	Grounded	Allows source input
	12	GND	I/O Signal Ground	-	I/O Ground for Reference and Control
	13	24Vo	+24VDC Output	-	Control voltage output (100mA Max)
	14	DO1	Digital Output 1	Ready	Shows the drive is ready to run
	15	24Vo	+24VDC Output	-	Control voltage output (100mA Max)
	16	GND	I/O Signal Ground	-	I/O Ground for Reference and Control
	17	AO1+	Analog Output 1	Output Frequency	Shows Output frequency to motor 0 - 60Hz (4-20mA)
	18	AO2+	Analog Output 2	Motor Current	Shows Motor current of motor 0-FLA (4-20mA)
	19	24Vi	+24VDC Input	-	External control voltage input
	20	DIN1	Digital Input 1	Run Forward	Input starts drive in forward direction (start enable)
	21	DIN2	Digital Input 2	Run Reverse	Input starts drive in reverse direction(start enable)
	22	DIN3	Digital Input 3	External Fault	Input causes drive to fault
	23	DIN4	Digital Input 4	Fault Reset	Input resets active faults
	24	CMA	DI1 to DI4 Common	Grounded	Allows source input
	25	A	RS-485 Signal A/+	-	Fieldbus Communication (Modbus, BACnet)
	26	B	RS-485 Signal B/-	-	Fieldbus Communication (Modbus, BACnet)
	27	R3NO	Relay 3 Normally Open	Fault	Relay output 3 shows VFD is Faulted
	28	R1NC	Relay 1 Normally Closed	Bypass Run	Relay output 1 shows VFD is in a bypass run state
	29	R1CM	Relay 1 Common	-	-
	30	R1NO	Relay 1 Normally Open	-	-
	31	R3CM	Relay 3 Common	Fault	Relay output 3 shows VFD is Faulted
	32	R2NC	Relay 2 Normally Closed	Run	Relay output 2 shows VFD is in a drive run state
	33	R2CM	Relay 2 Common	-	-
	34	R2NO	Relay 2 Normally Open	-	-

Note: The above wiring demonstrates a SINK configuration. It is important that CMA and CMB are wired to ground (as shown by dashed line). If a SOURCE configuration is desired, wire 24 V to CMA and CMB and close the inputs to ground. When using the +10 V for AI1, it is important to wire AI1—ground (as shown by dashed line). If using +10 V for AI1 or AI2, terminals 3, 5, and 6 need to be jumpered together.

① AI1+ and AI2+ Support 10K potentiometer.

Table 138. Drive Communication Ports

Port	Communication
RJ45 Keypad Port	
Upload/Download Parameters	USB to RJ45
Remote Mount Keypad	Ethernet
Upgrade Drive Firmware	USB to RJ45
RJ45 Ethernet Port	
Upload/Download Parameters	Ethernet
BACnet IP Communications	Ethernet
Modbus TCP Communications	Ethernet
RS-485 Serial Port [Ⓞ]	
Upload/Download Parameters	Two-Wire Twisted Pair
Upgrade Drive Firmware	Two-Wire Twisted Pair
Modbus RTU Communications	Two-Wire Twisted Pair
BACnet MS/TP Communications	Two-Wire Twisted Pair

[Ⓞ] Shielded wire recommended.

Advanced application—Parameters List

On the next pages you will find the lists of parameters within the respective parameter groups. The parameter descriptions are given in the Appendix A. The descriptions are arranged according to the parameter number.

Column explanations:

Code = Location indication on the keypad; shows the operator the present parameter number

Parameter = Name of parameter

Min = Minimum value of parameter

Max = Maximum value of parameter

Unit = Unit of parameter value; given if available

Default = Value preset by factory

ID = ID number of the parameter

Monitor

Table 139. Basic — M1

Code	Parameter	Min.	Max.	Unit	Default	ID	Note
M1.1	Output Frequency			Hz		1	
M1.2	Freq Reference			Hz		24	
M1.3	Motor Speed			rpm		2	
M1.4	Motor Current			A		3	
M1.5	Motor Torque			%		4	
M1.6	Motor Power			%		5	
M1.7	Motor Voltage			V		6	
M1.8	DC-link Voltage			V		7	
M1.9	Unit Temperature			°C		8	
M1.10	Motor Temperature			%		9	
M1.11	Latest Fault Code					28	
M1.12	Instant Motor Power			kW		1686	
M1.13	RTC Battery Status					583	0 = Not Installed 1 = Installed 2 = Change Battery 3 = OverVoltage

Table 140. IO Status — M2

Code	Parameter	Min.	Max.	Unit	Default	ID	Note
M2.1	Analog Input 1			Varies		10	
M2.2	Analog Input 2			Varies		11	
M2.3	Analog Output 1			Varies		25	
M2.4	Analog Output 2			Varies		575	
M2.5	DI1, DI2, DI3					12	
M2.6	DI4, DI5, DI6					13	
M2.7	DI7, DI8					576	
M2.8	DO1,Virtual RO1,Virtual RO2					14	
M2.9	RO1, RO2, RO3					557	

Table 141. Optional Boards — M3

Code	Parameter	Min.	Max.	Unit	Default	ID	Note
M3.1	PT100 Temperature			°	1000.0	27	

Table 142. Energy Savings — M4

Code	Parameter	Min.	Max.	Unit	Default	ID	Note
M4.1 [Ⓞ]	Energy Savings			Varies	0.000	2120	

Table 143. FB Monitor Menu — M5

Code	Parameter	Min.	Max.	Unit	Default	ID	Note
M5.1	Control Board DIDO Status					2209	Bit 0 = DIN1 Status Bit 1 = DIN2 Status Bit 2 = DIN3 Status Bit 3 = DIN4 Status Bit 4 = DIN5 Status Bit 5 = DIN6 Status Bit 6 = DIN7 Status Bit 7 = DIN8 Status Bit 8 = DO1 Status Bit 9 = RO1 Status Bit 10 = RO2 Status Bit 11 = RO3 Status Bit 12 = SlotA with board Bit 13 = SlotB with board Bit 14 = Virtual RO1 Status Bit 15 = Virtual RO2 Status
M5.2	SlotA DIDO Status					2210	Bit 0 = IO1_DIN1 Status Bit 1 = IO1_DIN2 Status Bit 2 = IO1_DIN3 Status Bit 3 = IO1_DO1 Status Bit 4 = IO1_DO2 Status Bit 5 = IO1_DO3 Status Bit 6 = IO3_RO1 Status Bit 7 = IO3_RO2 Status Bit 8 = IO3_RO3 Status Bit 9 = IO5_AC1 Status Bit 10 = IO5_AC2 Status Bit 11 = IO5_AC3 Status Bit 12 = IO5_AC4 Status Bit 13 = IO5_AC5 Status Bit 14 = IO5_AC6 Status
M5.3	SlotB DIDO Status					2211	Bit 0 = IO1_DI1 Bit 1 = IO1_DI2 Bit 2 = IO1_DI3 Bit 3 = IO1_DO1 Bit 4 = IO1_DO2 Bit 5 = IO1_DO3 Bit 6 = IO3_RO1 Bit 7 = IO3_RO2 Bit 8 = IO3_RO3 Bit 9 = IO5_AC1 Bit 10 = IO5_AC2 Bit 11 = IO5_AC3 Bit 12 = IO5_AC4 Bit 13 = IO5_AC5 Bit 14 = IO5_AC6 Bit 15 = Not Used

Note: [Ⓞ] Parameter value will be set to be default when changing macros.

Table 143. FB Monitor Menu — M5, continued

Code	Parameter	Min.	Max.	Unit	Default	ID	Note
M5.4	Application Status Word					29	Bit 0 = MC_Ready Bit 1 = MC_Run Bit 2 = MC_Fault or Fault Trip Bit 3 = FB_Ref_Active Bit 4 = MC_Stopping Bit 5 = MC_Reverse Bit 6 = MC_Warning or AR Bit 7 = MC_ZeroSpeed Bit 8 = IO Control Indicator Bit 9 = Panel Control Indicator Bit 10 = Panel Fieldbus Control Indicator Bit 11 = MC_DC_Brake Bit 12 = RunEnable Bit 13 = Run Bypass Bit 14 = External Brake Control Bit 15 = In Bypass Mode
M5.5	Standard Status Word					2414	Bit 0 = See PAR ID 2415 (default = Ready) Bit 1 = See PAR ID 2416 (default = Run) Bit 2 = See PAR ID 2417 (default = Fault) Bit 3 = See PAR ID 2418 (default = Fault Invert) Bit 4 = See PAR ID 2419 (default = Warning) Bit 5 = See PAR ID 2420 (default = Reversed) Bit 6 = See PAR ID 2421 (default = At Speed) Bit 7 = See PAR ID 2422 (default = Zero Frequency) Bit 8 - 15 = Not Used

Table 144. PID Monitor — M6

Code	Parameter	Min.	Max.	Unit	Default	ID	Note
M6.1	PID1 Set Point			Varies		16	
M6.2	PID1 Feedback			Varies		18	
M6.3	PID1 Error Value			Varies		20	
M6.4	PID1 Output			%		22	
M6.5	PID1 Status					23	0 = Stopped 1 = Running 2 = Sleep Mode
M6.6	PID2 Set Point			Varies		32	
M6.7	PID2 Feedback			Varies		34	
M6.8	PID2 Error Value			Varies		36	
M6.9	PID2 Output			%		38	
M6.10	PID2 Status					39	See Par ID 23

Table 145. Timer/Interval Control — M7

Code	Parameter	Min.	Max.	Unit	Default	ID	Note
M7.1	TC1, TC2, TC3					558	
M7.2	Interval 1					559	0 = Inactive 1 = Active
M7.3	Interval 2					560	See Par ID 559
M7.4	Interval 3					561	See Par ID 559
M7.5	Interval 4					562	See Par ID 559
M7.6	Interval 5					563	See Par ID 559
M7.7	Timer 1			s	0	569	
M7.8	Timer 2			s	0	571	
M7.9	Timer 3			s	0	573	

Table 146. User Defined Output — M8

Code	Parameter	Min.	Max.	Unit	Default	ID	Note
M8.1	Output			Varies		2445	
M8.2	Reference			Varies		2447	

Table 147. MWh Monitor — M9

Code	Parameter	Min.	Max.	Unit	Default	ID	Note
M9.1	Total MWh Count			Mwh		601	
M9.2	Total Power Day Count					603	
M9.3	Total Power Hr Count					606	
M9.4	Trip MWh Count			Mwh		604	
M9.5	Trip Power Day Count					636	
M9.6	Trip Power Hr Count					637	

Table 148. Multi-Monitoring — M10

Code	Parameter	Min.	Max.	Unit	Default	ID	Note
M10.1	Multi-Monitoring				1, 2, 3	30	

Parameters

Table 149. Basic Parameters — P1

Code	Parameter	Min.	Max.	Unit	Default	ID	Note
P1.1 ①②	Min Frequency	0.00	See Par ID 102	Hz	0.00	101	
P1.2 ①②	Max Frequency	See Par ID 101	400.00	Hz	Varies	102	
P1.3 ②	Accel Time 1	0.1	3000.0	s	20.0	103	
P1.4 ②	Decel Time 1	0.1	3000.0	s	20.0	104	
P1.5 ②	Motor Nom Current	DriveNomCurrCT*1/10	DriveNomCurrCT*2	A	DriveNomCurrCT	486	
P1.6 ②	Motor Nom Speed	300	20000	rpm	Varies	489	
P1.7 ②	Motor PF	0.30	1.00		0.85	490	
P1.8 ②	Motor Nom Voltage	180	690	V	Varies	487	
P1.9 ②	Motor Nom Frequency	8.00	400.00	Hz	Varies	488	
P1.10 ①②	HOA Source				0	2465	0 = I/O Terminal/ Keypad/Fieldbus 1 = Keypad 2 = IO Terminal 3 = Fieldbus

Note: ① Parameter value can only be changed after the drive has stopped.

② Parameter value will be set to be default when changing macros.

Table 149. Basic Parameters — P1, continued

Code	Parameter	Min.	Max.	Unit	Default	ID	Note
P1.11 ②	Hand Control Place				0	1695	0 = Keypad 1 = I/O Terminal Start 1 2 = I/O Terminal Start 2 3 = Fieldbus
P1.12 ①②	Hand Reference				6	136	0 = AI1 1 = AI2 2 = Slot A: AI1 3 = Slot B: AI1 4 = AI1 Joystick 5 = AI2 Joystick 6 = Keypad 7 = Fieldbus Ref 9 = Max Frequency 10 = AI1 + AI2 11 = AI1 - AI2 12 = AI2 - AI1 13 = AI1 * AI2 14 = AI1 or AI2 15 = MIN(AI1,AI2) 16 = MAX(AI1,AI2) 17 = PID1 Control Output 18 = PID2 Control Output
P1.13 ②	Auto 1 Control Place				0	135	0 = I/O Terminal Start 1 1 = Fieldbus 2 = I/O Terminal Start 2 3 = Keypad
P1.14 ①②	Auto 1 Reference				1	137	See Par ID 136
P1.15 ②	Auto 2 Control Place				1	138	See Par ID 135
P1.16 ①②	Auto 2 Reference				7	139	See Par ID 136

Table 150. Basic Setting — P2.1

Code	Parameter	Min.	Max.	Unit	Default	ID	Note
P2.1.1 ①②	Damper Start				0	483	0 = Normal 1 = Interlock Start 2 = Interlock Tout 3 = Interlock Delay
P2.1.2 ①②	Damper Time Out	1	32500	s	5	484	
P2.1.3 ①②	Damper Delay	1	32500	s	5	485	
P2.1.4 ②	AI Ref Scale Min Value	0.00	See Par ID 145	Hz	0.00	144	
P2.1.5 ②	AI Ref Scale Max Value	See Par ID 144	400.00	Hz	0.00	145	

Note: ① Parameter value can only be changed after the drive has stopped.

② Parameter value will be set to be default when changing macros.

Table 151. Digital Input — P2.2

Code	Parameter	Min.	Max.	Unit	Default	ID	Note
P2.2.1 ①②	IO Terminal 1 Start Stop Logic				0	143	0 = Forward - Reverse 1 = Start - Reverse 2 = Start - Enable 3 = Start Pulse - Stop Pulse
P2.2.2 ②③	IO Terminal 1 Start Signal 1				2	190	0 = DigIN:NormallyOpen 1 = DigIN:NormallyClose 2 = DigIN: 1 3 = DigIN: 2 4 = DigIN: 3 5 = DigIN: 4 6 = DigIN: 5 7 = DigIN: 6 8 = DigIN: 7 9 = DigIN: 8 10 = DigIN: A: IO1: 1 11 = DigIN: A: IO1: 2 12 = DigIN: A: IO1: 3 13 = DigIN: A: IO5: 1 14 = DigIN: A: IO5: 2 15 = DigIN: A: IO5: 3 16 = DigIN: A: IO5: 4 17 = DigIN: A: IO5: 5 18 = DigIN: A: IO5: 6 19 = DigIN: B: IO1: 1 20 = DigIN: B: IO1: 2 21 = DigIN: B: IO1: 3 22 = DigIN: B: IO5: 1 23 = DigIN: B: IO5: 2 24 = DigIN: B: IO5: 3 25 = DigIN: B: IO5: 4 26 = DigIN: B: IO5: 5 27 = DigIN: B: IO5: 6 28 = Time Channel 1 29 = Time Channel 2 30 = Time Channel 3 31 = RO1 Function 32 = RO2 Function 33 = RO3 Function 34 = Virtual RO1 Function 35 = Virtual RO2 Function
P2.2.3 ②③	IO Terminal 1 Start Signal 2				3	191	See Par ID 190
P2.2.4 ①②	IO Terminal 2 Start Stop Logic				0	2206	See Par ID 143
P2.2.5 ②③	IO Terminal 2 Start Signal 1				2	2207	See Par ID 190
P2.2.6 ②③	IO Terminal 2 Start Signal 2				3	2208	See Par ID 190
P2.2.7 ①②	Thermistor Input Select				0	881	0 = Digital Input 1 = Thermistor Input
P2.2.8 ②③	Reverse				0	198	See Par ID 190
P2.2.9 ②③	Ext. Fault 1 NO				4	192	See Par ID 190
P2.2.10 ②③	Ext. Fault 1 NC				1	193	See Par ID 190

Note: ① Parameter value can only be changed after the drive has stopped.
 ② Parameter value will be set to be default when changing macros.
 ③ Input function is level sensed.
 ④ Input function is edge sensed.
 ⑤ Input function is edge sensed when using StartP/StopP start logic.

Chapter 7—Advanced application parameter

Table 151. Digital Input — P2.2, continued

Code	Parameter	Min.	Max.	Unit	Default	ID	Note
P2.2.11 ②	Ext. Fault 1 Text				0	2297	0 = External Fault 1 = Vibration Cut out 2 = High Motor temp 3 = Low Pressure 4 = High Pressure 5 = Low Water 6 = Damper Interlock 7 = Run Enable 8 = Freeze Stat Trip 9 = Smoke Detect 10 = Seal Leakage 11 = Rod Breakage
P2.2.12 ③③	Ext. Fault 2 NO				0	2293	See Par ID 190
P2.2.13 ③③	Ext. Fault 2 NC				1	2294	See Par ID 190
P2.2.14 ②	Ext. Fault 2 Text				1	2298	See Par ID 2297
P2.2.15 ③③	Ext. Fault 3 NO				0	2295	See Par ID 190
P2.2.16 ③③	Ext. Fault 3 NC				1	2296	See Par ID 190
P2.2.17 ②	Ext. Fault 3 Text				2	2299	See Par ID 2297
P2.2.18 ④④	Fault Reset				5	200	See Par ID 190
P2.2.19 ③③	Run Enable				1	194	See Par ID 190
P2.2.20 ③③	Preset Speed B0				6	205	See Par ID 190
P2.2.21 ③③	Preset Speed B1				0	206	See Par ID 190
P2.2.22 ③③	Preset Speed B2				0	207	See Par ID 190
P2.2.23 ③③	Jog Enable				0	199	See Par ID 190
P2.2.24 ③③	Accel/Decel Time Set				0	195	See Par ID 190
P2.2.25 ③③	Accel/Decel Prohibit				0	201	See Par ID 190
P2.2.26 ④④	No Access To Param				0	215	See Par ID 190
P2.2.27 ③③	Auto Control				9	196	See Par ID 190
P2.2.28 ③③	Hand Control				0	197	See Par ID 190
P2.2.29 ③③	Auto 1/2 Select				0	209	See Par ID 190
P2.2.30 ③③	HOA On/Off				1	2395	See Par ID 190
P2.2.31 ③③	Second Motor Para Select				0	217	See Par ID 190
P2.2.32 ④④	Parameter Set1/2 Sel				0	2312	See Par ID 190
P2.2.33 ③③	AI Ref Source Select				0	208	See Par ID 190
P2.2.34 ③③	Bypass Start				8	218	See Par ID 190
P2.2.35 ③③	Bypass Overload				0	1246	See Par ID 190
P2.2.36 ③③	PID1 Control Enable				1	550	See Par ID 190
P2.2.37 ③③	PID2 Control Enable				1	553	See Par ID 190
P2.2.38 ③③	PID1 Set Point Select				0	351	See Par ID 190
P2.2.39 ③③	PID2 Set Point Select				0	352	See Par ID 190
P2.2.40 ③③	DC Brake Active				0	202	See Par ID 190
P2.2.41 ③③	Smoke Mode				0	219	See Par ID 190
P2.2.42 ③③	Fire Mode				7	220	See Par ID 190
P2.2.43 ③③	Fire Mode Ref 1/2 Select				0	221	See Par ID 190
P2.2.44 ③③	Fire Mode Reverse				0	2119	See Par ID 190
P2.2.45 ③③	Start Timer 1				0	224	See Par ID 190
P2.2.46 ③③	Start Timer 2				0	225	See Par ID 190
P2.2.47 ③③	Start Timer 3				0	226	See Par ID 190

- Note:**
- ① Parameter value can only be changed after the drive has stopped.
 - ② Parameter value will be set to be default when changing macros.
 - ③ Input function is level sensed.
 - ④ Input function is edge sensed when using StartP/StopP start logic.

Table 152. Preset Speed — P2.3

Code	Parameter	Min.	Max.	Unit	Default	ID	Note
P2.3.1 [Ⓢ]	Preset Speed 1	0.00	See Par ID 102	Hz	5.00	105	
P2.3.2 [Ⓢ]	Preset Speed 2	0.00	See Par ID 102	Hz	10.00	106	
P2.3.3 [Ⓢ]	Preset Speed 3	0.00	See Par ID 102	Hz	15.00	118	
P2.3.4 [Ⓢ]	Preset Speed 4	0.00	See Par ID 102	Hz	20.00	119	
P2.3.5 [Ⓢ]	Preset Speed 5	0.00	See Par ID 102	Hz	25.00	120	
P2.3.6 [Ⓢ]	Preset Speed 6	0.00	See Par ID 102	Hz	30.00	121	
P2.3.7 [Ⓢ]	Preset Speed 7	0.00	See Par ID 102	Hz	35.00	122	
P2.3.8 [Ⓢ]	Jog Reference	See Par ID 101	See Par ID 102	Hz	0.00	117	

Table 153. Preset Speed — P2.3

Code	Parameter	Min.	Max.	Unit	Default	ID	Note
P2.4.1	AI1 Mode				1	222	0 = 0 - 20 mA 1 = 0 -10 V
P2.4.2 [Ⓢ]	AI1 Signal Range				0	175	0 = 0-100%/0-20mA/0-10V 1 = 20-100%/4-20mA/2-10V 2 = Customized
P2.4.3 [Ⓢ]	AI1 Custom Min	0.00	See Par ID 177	%	0.00	176	
P2.4.4 [Ⓢ]	AI1 Custom Max	See Par ID 176	100.00	%	100.00	177	
P2.4.5 [Ⓢ]	AI1 Filter Time	0.00	10.00	s	0.10	174	
P2.4.6 [Ⓢ]	AI1 Signal Invert				0	181	0 = Not Inverted 1 = Inverted
P2.4.7 [Ⓢ]	AI1 Joystick Hyst	0.00	20.00	%	0.00	178	
P2.4.8 [Ⓢ]	AI1 Sleep Limit	0.00	100.00	%	0.00	179	
P2.4.9 [Ⓢ]	AI1 Sleep Delay	0.00	320.00	s	0.00	180	
P2.4.10 [Ⓢ]	AI1 Joystick Offset	-50.00	50.00	%	0.00	133	

Table 154. Preset Speed — P2.3

Code	Parameter	Min.	Max.	Unit	Default	ID	Note
P2.5.1	AI2 Mode				0	223	0 = 0 - 20 mA 1 = 0 -10 V 2 = -10 - +10 V
P2.5.2 [Ⓢ]	AI2 Signal Range				1	183	0 = 0-100%/0-20mA/0-10V/-10-10V 1 = 20-100%/4-20mA/2-10V/-6-10V 2 = Customized
P2.5.3 [Ⓢ]	AI2 Custom Min	0.00	See Par ID 185	%	0.00	184	
P2.5.4 [Ⓢ]	AI2 Custom Max	See Par ID 184	100.00	%	100.00	185	
P2.5.5 [Ⓢ]	AI2 Filter Time	0.00	10.00	s	0.10	182	
P2.5.6 [Ⓢ]	AI2 Signal Invert				0	189	See Par ID 181
P2.5.7 [Ⓢ]	AI2 Joystick Hyst	0.00	20.00	%	0.00	186	
P2.5.8 [Ⓢ]	AI2 Sleep Limit	0.00	100.00	%	0.00	187	
P2.5.9 [Ⓢ]	AI2 Sleep Delay	0.00	320.00	s	0.00	188	
P2.5.10 [Ⓢ]	AI2 Joystick Offset	-50.00	50.00	%	0.00	134	

Note: [Ⓢ] Parameter value will be set to be default when changing macros.

Outputs

Table 155. Digital Output — P3.1

Code	Parameter	Min.	Max.	Unit	Default	ID	Note
P3.1.1 ②	DO1 Function				1	151	0 = Not Used 1 = Ready 2 = Run 3 = Fault 4 = Fault Invert 5 = Warning 6 = Reversed 7 = At Speed 8 = Zero Frequency 9 = Freq Limit 1 Superv 10 = Freq Limit 2 Superv 11 = PID1 Superv 12 = PID2 Superv 13 = OverHeat Fault 14 = OverCurrent Regular 15 = OverVoltage Regular 16 = UnderVoltage Regular 17 = 4mA Ref Fault/Warning 20 = Torq Limit Superv 21 = Ref Limit Superv 22 = Control from I/O 23 = Un-Requested Rotation Direction 24 = Thermistor Fault Output 25 = Fire Mode 26 = In Bypass Mode 27 = Ext Fault/Warning 28 = Auto Control 29 = Jog Speed Select 30 = Motor Therm Protection 31 = FB Digital Input 1 32 = FB Digital Input 2 33 = FB Digital Input 3 34 = FB Digital Input 4 35 = Damper Control 36 = TC1 Status 37 = TC2 Status 38 = TC3 Status 40 = Power Limit Superv 41 = Temp Limit Superv 42 = Analog Input Superv 43 = Motor 1 Control 48 = Logic Fulfilled 49 = PID1 Sleep 50 = PID2 Sleep 51 = Motor Current 1 Supv 52 = Motor Current 2 Supv 53 = Second AI Limit Supv 54 = DC Charge Switch Close 55 = Preheat Active 56 = Cold Weather Active 58 = 2th Stage Ramp Frequency Active 59 = STO Fault Output 60 = Run Bypass/Drive 61 = Bypass Overload 62 = Bypass Run

Note: ② Parameter value will be set to be default when changing macros.

Table 155. Digital Output — P3.1, continued

Code	Parameter	Min.	Max.	Unit	Default	ID	Note
P3.1.2 [Ⓢ]	RO1 Function				62	152	See Par ID 151
P3.1.3 [Ⓢ]	RO1 On Delay	0.0	320.0	s	0.0	2112	
P3.1.4 [Ⓢ]	RO1 Off Delay	0.0	320.0	s	0.0	2113	
P3.1.5 [Ⓢ]	RO2 Function				2	153	See Par ID 151
P3.1.6 [Ⓢ]	RO2 On Delay	0.0	320.0	s	0.0	2114	
P3.1.7 [Ⓢ]	RO2 Off Delay	0.0	320.0	s	0.0	2115	
P3.1.8 [Ⓢ]	RO3 Function				3	538	See Par ID 151
P3.1.9 [Ⓢ]	RO3 On Delay	0.0	320.0	s	0.0	2116	
P3.1.10 [Ⓢ]	RO3 Off Delay	0.0	320.0	s	0.0	2117	
P3.1.11 [Ⓢ]	RO3 Reverse				0	2118	0 = No 1 = Yes
P3.1.12 [Ⓢ]	Virtual RO1 Function				0	2463	See Par ID 151
P3.1.13 [Ⓢ]	Virtual RO2 Function				0	2464	See Par ID 151

Table 156. Supervisions — P3.2

Code	Parameter	Min.	Max.	Unit	Default	ID	Note
P3.2.1 [Ⓢ]	Freq Limit 1 Supv				0	154	0 = No Limit 1 = Low Limit Superv 2 = High Limit Superv
P3.2.2 [Ⓢ]	Freq Limit 1 Supv Val	0.00	See Par ID 102	Hz	0.00	155	
P3.2.3 [Ⓢ]	Freq Limit 1 Supv Hyst	0.10	1.00	Hz	0.10	2200	
P3.2.4 [Ⓢ]	Freq Limit 2 Supv				0	157	See Par ID 154
P3.2.5 [Ⓢ]	Freq Limit 2 Supv Val	0.00	See Par ID 102	Hz	0.00	158	
P3.2.6 [Ⓢ]	Freq Limit 2 Supv Hyst	0.10	1.00	Hz	0.10	2201	
P3.2.7 [Ⓢ]	Torque Limit Supv				0	159	See Par ID 154
P3.2.8 [Ⓢ]	Torque Limit Supv Val	-1000.0	1000.0	%	100.0	160	
P3.2.9 [Ⓢ]	Torque Limit Supv Hyst	1.0	5.0	%	1.0	2202	
P3.2.10 [Ⓢ]	Ref Limit Supv				0	161	See Par ID 154
P3.2.11 [Ⓢ]	Ref Limit Supv Val	0.00	See Par ID 102	Hz	0.00	162	
P3.2.12 [Ⓢ]	Ref Limit Supv Hyst	0.10	1.00	Hz	0.10	2203	
P3.2.13 [Ⓢ]	Temp Limit Supv				0	165	See Par ID 154
P3.2.14 [Ⓢ]	Temp Limit Supv Val	-10.0	75.0	°C	40.0	166	
P3.2.15 [Ⓢ]	Temp Limit Supv Hyst	1.0	10.0	°C	1.0	2204	
P3.2.16 [Ⓢ]	Power Limit Supv				0	167	See Par ID 154
P3.2.17 [Ⓢ]	Power Limit Supv Val	-200.0	200.0	%	0.0	168	
P3.2.18 [Ⓢ]	Power Limit Supv Hyst	0.1	10.0	%	0.1	2205	
P3.2.19 [Ⓢ]	AI Supv Select				0	170	0 = AI1 1 = AI2
P3.2.20 [Ⓢ]	AI Limit Supv				0	171	See Par ID 154
P3.2.21 [Ⓢ]	AI Limit Supv Val	0.00	100.00	%	0.00	172	
P3.2.22 [Ⓢ]	AI Supv Hyst	1.00	10.00	%	1.00	2198	
P3.2.23 [Ⓢ]	Motor Current 1 Supv				0	2189	See Par ID 154
P3.2.24 [Ⓢ]	Motor Current 1 Supv Value	0.0	DriveNomCurrCT*2	A	DriveNomCurrCT	2190	
P3.2.25 [Ⓢ]	Motor Current 1 Supv Hyst	0.1	1.0	A	0.1	2196	
P3.2.26 [Ⓢ]	Motor Current 2 Supv				0	2191	See Par ID 154
P3.2.27 [Ⓢ]	Motor Current 2 Supv Value	0.0	DriveNomCurrCT*2	A	DriveNomCurrCT	2192	
P3.2.28 [Ⓢ]	Motor Current 2 Supv Hyst	0.1	1.0	A	0.1	2197	
P3.2.29 [Ⓢ]	Second AI Supv Select				0	2193	See Par ID 170
P3.2.30 [Ⓢ]	Second AI Limit Supv				0	2194	See Par ID 154

Note: [Ⓢ] Parameter value will be set to be default when changing macros.

Chapter 7—Advanced application parameter

Table 156. Supervisions — P3.2, continued

Code	Parameter	Min.	Max.	Unit	Default	ID	Note
P3.2.31 [Ⓢ]	Second AI Limit Supv Val	0.00	100.00	%	0.00	2195	
P3.2.32 [Ⓢ]	Second AI Supv Hyst	1.00	10.00	%	1.00	2199	
P3.2.33 [Ⓢ]	PID1 Superv Enable				0	1346	0 = Disabled 1 = Enabled
P3.2.34 [Ⓢ]	PID1 Superv Upper Limit	See Par ID 1298	See Par ID 1300	Varies	0.00	1347	
P3.2.35 [Ⓢ]	PID1 Superv Lower Limit	See Par ID 1298	See Par ID 1300	Varies	0.00	1349	
P3.2.36 [Ⓢ]	PID1 Superv Delay	0	3000	s	0	1351	
P3.2.37 [Ⓢ]	PID2 Superv Enable				0	1408	See Par ID 1346
P3.2.38 [Ⓢ]	PID2 Superv Upper Limit	See Par ID 1360	See Par ID 1362	Varies	0.00	1409	
P3.2.39 [Ⓢ]	PID2 Superv Lower Limit	See Par ID 1360	See Par ID 1362	Varies	0.00	1411	
P3.2.40 [Ⓢ]	PID2 Superv Delay	0	3000	s	0	1413	

Table 157. Supervisions — P3.2

Code	Parameter	Min.	Max.	Unit	Default	ID	Note
P3.3.1 [Ⓢ]	AO1 Mode				0	227	See Par ID 222
P3.3.2 [Ⓢ]	AO1 Function				1	146	0 = Not Used 1 = Output Frequency 2 = Freq Reference 3 = Motor Speed (0-Nom) 4 = Motor Current (0-Nom) 5 = Motor Torque (0-Nom) 6 = Motor Power (0-Nom) 7 = Motor Voltage (0-Nom) 8 = DC-Bus Voltage 9 = PID1 Setpoint 10 = PID1 Feedback 1 11 = PID1 Feedback 2 12 = PID1 Control Error Value 13 = PID1 Control Output 14 = PID2 Setpoint 15 = PID2 Feedback 1 16 = PID2 Feedback 2 17 = PID2 Control Error Value 18 = PID2 Control Output 19 = AI1 20 = AI2 21 = Output Freq (-2-+2N) 22 = Motor Torque (-2-+2N) 23 = Motor Power (-2-+2N) 24 = PT100 Temperature 25 = FB Process Data Input 1 26 = FB Process Data Input 2 27 = FB Process Data Input 3 28 = FB Process Data Input 4 29 = FB Process Data Input 5 30 = FB Process Data Input 6 31 = FB Process Data Input 7 32 = FB Process Data Input 8 33 = SlotA PT100 Temp Channel 1 34 = SlotA PT100 Temp Channel 2 35 = SlotA PT100 Temp Channel 3 36 = SlotB PT100 Temp Channel 1 37 = SlotB PT100 Temp Channel 2 38 = SlotB PT100 Temp Channel 3 39 = User Defined Output 40 = Motor Current (-2-+2N)

Note: [Ⓢ] Parameter value will be set to be default when changing macros.

Table 157. Supervisions — P3.2, continued

Code	Parameter	Min.	Max.	Unit	Default	ID	Note
P3.3.3 [Ⓢ]	A01 Minimum				1	149	0 = 0V / 0 mA 1 = 2V / 4 mA
P3.3.4 [Ⓢ]	A01 Filter Time	0.00	0.00	s	1.00	147	
P3.3.5 [Ⓢ]	A01 Scale	10	10	%	100	150	
P3.3.6 [Ⓢ]	A01 Inversion				0	148	See Par ID 181
P3.3.7 [Ⓢ]	A01 Offset	-100.00	-100.00	%	0.00	173	

Table 158. Analog Output 2 — P3.4

Code	Parameter	Min.	Max.	Unit	Default	ID	Note
P3.4.1 [Ⓢ]	A02 Mode				0	228	See Par ID 222
P3.4.2 [Ⓢ]	A02 Function				4	229	See Par ID 146
P3.4.3 [Ⓢ]	A02 Minimum				1	232	See Par ID 149
P3.4.4 [Ⓢ]	A02 Filter Time	0.00	10.00	s	1.00	230	
P3.4.5 [Ⓢ]	A02 Scale	10	1000	%	100	233	
P3.4.6 [Ⓢ]	A02 Inversion				0	231	See Par ID 181
P3.4.7 [Ⓢ]	A02 Offset	-100.00	100.00	%	0.00	234	

Table 159. Logic Function — P3.5

Code	Parameter	Min.	Max.	Unit	Default	ID	Note
P3.5.1 [Ⓢ]	Logic Function Select				0	751	0 = AND 1 = OR 2 = XOR
P3.5.2 [Ⓢ]	Logic Operation Input A				0	752	0 = Not Used 1 = Ready 2 = Run 3 = Fault 6 = Reversed 7 = Warning 8 = Zero Frequency 9 = Control from I/O 14 = Run Bypass/Drive 16 = In Bypass Mode 17 = At Speed 18 = Auto Control 19 = Freq Limit 1 Superv 20 = Freq Limit 2 Superv 22 = PID1 Superv 23 = PID2 Superv 24 = OverHeat Fault 28 = 4mA Ref Fault/ Warning 29 = OverCurrent Regular 30 = OverVoltage Regular 31 = UnderVoltage Regular 32 = Torq Limit Superv 33 = Ref Limit Superv 34 = Un-Requested Rotation Direction 35 = Thermal Fault/ Warning

Note: [Ⓢ] Parameter value will be set to be default when changing macros.

Chapter 7—Advanced application parameter

Table 159. Logic Function — P3.5, continued

Code	Parameter	Min.	Max.	Unit	Default	ID	Note
P3.5.2 ②	Logic Operation Input A				0	752	36 = Bypass Enable 37 = Jog Speed Select 38 = Motor Therm Protection 39 = FB Digital Input 1 40 = FB Digital Input 2 41 = FB Digital Input 3 42 = FB Digital Input 4 43 = Damper Control 44 = TC1 Status 45 = TC2 Status 46 = TC3 Status 48 = Power Limit Superv 49 = Temp Limit Superv 50 = Analog Input Superv 56 = Logic Fulfilled
P3.5.3 ②	Logic Operation Input B				0	753	See Par ID 752

Drive Control

Table 160. Basic Setting — P4.1

Code	Parameter	Min.	Max.	Unit	Default	ID	Note
P4.1.1 ②	Keypad Reference	See Par ID 101	See Par ID 102	Hz	0.00	141	
P4.1.2 ②	Keypad Direction				0	116	0 = Forward 1 = Reverse
P4.1.3 ②	Keypad Stop				1	114	0 = Enabled-Keypad Operation 1 = Always Enabled
P4.1.4 ②	Hand Key Enable				0	1724	0 = Enabled 1 = Disabled
P4.1.5 ②	Reverse Enable				1	1679	See Par ID 1346
P4.1.6	Change PhaseSequence Motor				0	2515	0 = Change Disable 1 = Change Enable
P4.1.7 ②	Power Up HOA Select				0	1685	0 = Hold Last 1 = Hand Control 2 = Auto control 3 = Off
P4.1.8 ②	Bumpless Enable				0	2462	See Par ID 1346
P4.1.9 ②	Run Delay Time	0	32500	s	0	2423	
P4.1.10 ②	Start Mode				0	252	0 = Ramp 1 = Flying Start
P4.1.11 ②	Stop Mode				0	253	0 = Coasting 1 = Ramp
P4.1.12 ②	Ramp 1 Shape	0.0	10.0	s	0.0	247	
P4.1.13 ②	Ramp 2 Shape	0.0	10.0	s	0.0	248	
P4.1.14 ②	Accel Time 2	0.1	3000.0	s	10.0	249	
P4.1.15 ②	Decel Time 2	0.1	3000.0	s	10.0	250	
P4.1.16 ②	Power Loss Function				0	267	See Par ID 1346
P4.1.17 ②	Power Loss Time	0.3	5.0	s	2.0	268	
P4.1.18 ②③	2nd Stage Ramp Frequency	See Par ID 101	See Par ID 102	Hz	30.00	2444	

Note: ① Parameter value can only be changed after the drive has stopped.

② Parameter value will be set to be default when changing macros.

Table 161. Brake — P4.2

Code	Parameter	Min.	Max.	Unit	Default	ID	Note
P4.2.1 ①②	DC-Brake Current	DriveNomCurrCT *15/100	DriveNomCurrCT *15/10	A	DriveNomCurrCT *1/2	254	
P4.2.2 ①②	Start DC-Brake Time	0.00	600.00	s	0.00	263	
P4.2.3 ①②	Stop DC-Brake Frequency	0.10	10.00	Hz	1.50	262	
P4.2.4 ①②	Stop DC-Brake Time	0.00	600.00	s	0.00	255	
P4.2.5 ①②	Brake Chopper Define				0	251	0 = Disabled 1 = B(Run) T(Rdy) 2 = External 3 = B(Rdy) T(Rdy) 4 = B(Run) T(No)
P4.2.6 ①②	Flux Brake					266	0 = Off 1 = On
P4.2.7 ①②	Flux Brake Current	ActiveMotorNomCurr *1/10	See Par ID 107	A	ActiveMotorNomCurr *1/2	265	

Table 162. Skip Frequency — P4.3

Code	Parameter	Min.	Max.	Unit	Default	ID	Note
P4.3.1 ②	Skip Range Ramp Factor	0.1	10.0		1.0	264	
P4.3.2 ②	Skip F1 Low Limit	0.00	See Par ID 257	Hz	0.00	256	
P4.3.3 ②	Skip F1 High Limit	See Par ID 256	400.00	Hz	0.00	257	
P4.3.4 ②	Skip F2 Low Limit	0.00	See Par ID 259	Hz	0.00	258	
P4.3.5 ②	Skip F2 High Limit	See Par ID 258	400.00	Hz	0.00	259	
P4.3.6 ②	Skip F3 Low Limit	0.00	See Par ID 261	Hz	0.00	260	
P4.3.7 ②	Skip F3 High Limit	See Par ID 260	400.00	Hz	0.00	261	

Table 163. Energy Savings Calc — P4.4

Code	Parameter	Min.	Max.	Unit	Default	ID	Note
P4.4.1 ②	Currency				0	2122	0 = \$ 1 = £ 2 = € 3 = ¥ 4 = Rs 5 = R\$ 6 = Fr 7 = kr
P4.4.2 ②	Energy Cost			Varies	0	2123	
P4.4.3 ②	Data Type				0	2124	0 = Cumulative 1 = Daily Avg 2 = Weekly Avg 3 = Monthly Avg 4 = Yearly Avg
P4.4.4	Energy Savings Reset					2125	0 = Not Reset 1 = Reset

Motor Control

Table 164. Basic Setting — P5.1

Code	Parameter	Min.	Max.	Unit	Default	ID	Note
P5.1.1 ①②	Motor Control Mode				0	287	0 = Freq Control 1 = Speed Control
P5.1.2 ②	Current Limit	DriveNomCurrCT *1/10	DriveNomCurrCT *2	A	DriveNomCurrCT *2	107	

Note: ① Parameter value can only be changed after the drive has stopped.

② Parameter value will be set to be default when changing macros.

Chapter 7—Advanced application parameter

Table 164. Basic Setting — P5.1, continued

Code	Parameter	Min.	Max.	Unit	Default	ID	Note
P5.1.3 ①②	V/Hz Optimization				0	109	See Par ID 1346
P5.1.4 ①②	V/Hz Ratio				3	108	0 = Linear 1 = Squared 2 = Programmable 3 = Linear + Flux Optimization
P5.1.5 ①②	Field Weakening Point	8.00	400.00	Hz	Varies	289	
P5.1.6 ①②	Voltage at FWP	10.00	200.00	%	100.00	290	
P5.1.7 ①②	V/Hz Mid Frequency	0.00	See Par ID 289	Hz	Varies	291	
P5.1.8 ①②	V/Hz Mid Voltage	0.00	100.00	%	100.00	292	
P5.1.9 ①②	Zero Frequency Voltage	0.00	40.00	%	0.00	293	
P5.1.10 ②	Switching Frequency	MinSwitchFreq	MaxSwitchFreq	kHz	DefaultSwitchFreqCT	288	
P5.1.11 ④	Sine Filter Enable				0	1665	See Par ID 1346
P5.1.12 ①②	OverVoltage Control				1	294	See Par ID 1346
P5.1.13 ④	Load Drooping	0.00	100.00	%	0.00	298	
P5.1.14 ④	Droop Control Filter Time Constant	0	3000	ms	0	1630	

Table 165. Second Motor Parameter — P5.2

Code	Parameter	Min.	Max.	Unit	Default	ID	Note
P5.2.1 ④	Motor Nom Current 2	DriveNomCurrCT*1/10	DriveNomCurrCT*2	A	DriveNomCurrCT	577	
P5.2.2 ④	Motor Nom Speed 2	300	20000	rpm	Varies	578	
P5.2.3 ④	Motor PF 2	0.30	1.00		0.85	579	
P5.2.4 ④	Motor Nom Volt 2	180	690	V	Varies	580	
P5.2.5 ④	Motor Nom Freq 2	8.00	400.00	Hz	Varies	581	

Protections

Table 166. Motor — P6.1

Code	Parameter	Min.	Max.	Unit	Default	ID	Note
P6.1.1 ①②	Output Phase Fault				2	308	0 = No Action 1 = Warning 2 = Fault 3 = Fault, Coast
P6.1.2 ①②	Ground Fault				2	309	See Par ID 308
P6.1.3 ②	Ground Fault Limit	0	30	%	15	2158	
P6.1.4 ①②	Motor Thermal Protection				2	310	See Par ID 308
P6.1.5 ②	Motor Thermal FO Current	0.0	150.0	%	40.0	311	
P6.1.6 ②	Motor Thermal Time	1	200	min	12	312	
P6.1.7 ①②	Stall Protection				0	313	See Par ID 308
P6.1.8 ②	Stall Current Limit	0.1	ActiveMotorNomCurr*2	A	ActiveMotorNomCurr*13/10	314	
P6.1.9 ②	Stall Time Limit	1.0	120.0	s	15.0	315	
P6.1.10 ②	Stall Frequency Limit	1.00	See Par ID 102	Hz	25.00	316	
P6.1.11 ①②	Underload Protection				0	317	See Par ID 308
P6.1.12 ②	Underload Fnom Torque	10.0	150.0	%	50.0	318	
P6.1.13 ②	Underload FO Torque	5.0	150.0	%	10.0	319	
P6.1.14 ②	Underload Time Limit	2.00	600.00	s	20.00	320	
P6.1.15 ①②	Thermistor Fault Response				2	333	See Par ID 308
P6.1.16 ①②	PT100 Fault Response				2	337	See Par ID 308
P6.1.17 ②	Preheat Mode				0	2159	See Par ID 1346

Note: ① Parameter value can only be changed after the drive has stopped.

② Parameter value will be set to be default when changing macros.

Table 166. Motor — P6.1, continued

Code	Parameter	Min.	Max.	Unit	Default	ID	Note
P6.1.18 [Ⓢ]	Preheat Control Source				31	2160	0 = DigIN:NormallyOpen 1 = DigIN:NormallyClose 2 = DigIN: 1 3 = DigIN: 2 4 = DigIN: 3 5 = DigIN: 4 6 = DigIN: 5 7 = DigIN: 6 8 = DigIN: 7 9 = DigIN: 8 10 = DigIN: A: IO1: 1 11 = DigIN: A: IO1: 2 12 = DigIN: A: IO1: 3 13 = DigIN: A: IO5: 1 14 = DigIN: A: IO5: 2 15 = DigIN: A: IO5: 3 16 = DigIN: A: IO5: 4 17 = DigIN: A: IO5: 5 18 = DigIN: A: IO5: 6 19 = DigIN: B: IO1: 1 20 = DigIN: B: IO1: 2 21 = DigIN: B: IO1: 3 22 = DigIN: B: IO5: 1 23 = DigIN: B: IO5: 2 24 = DigIN: B: IO5: 3 25 = DigIN: B: IO5: 4 26 = DigIN: B: IO5: 5 27 = DigIN: B: IO5: 6 28 = Time Channel 1 29 = Time Channel 2 30 = Time Channel 3 31 = Drive Temperature 32 = SlotA PT100 Temp Channel 1 33 = SlotA PT100 Temp Channel 2 34 = SlotA PT100 Temp Channel 3 35 = SlotA Max PT100 Temp 36 = SlotB PT100 Temp Channel 1 37 = SlotB PT100 Temp Channel 2 38 = SlotB PT100 Temp Channel 3 39 = SlotB Max PT100 Temp 40 = SlotA and SlotB Max PT100 Temp

Note: [Ⓢ] Parameter value can only be changed after the drive has stopped.

[Ⓣ] Parameter value will be set to be default when changing macros.

Chapter 7—Advanced application parameter

Table 166. Motor — P6.1, continued

Code	Parameter	Min.	Max.	Unit	Default	ID	Note
P6.1.19 ②	Preheat Enter Temp	0.0	19.9	°C	10.0	2161	
P6.1.20 ②	Preheat Quit Temp	20.0	40.0	°C	20.0	2162	
P6.1.21 ②	Preheat Output Volt	0.0	20.0	%	2.0	2163	

Table 167. Drive — P6.2

Code	Parameter	Min.	Max.	Unit	Default	ID	Note
P6.2.1 ②	Line Start Lockout				2	750	0 = Disabled, No Change 1 = Enable, No Change 2 = Disabled, Changed 3 = Enable, Changed
P6.2.2 ②	Fault Reset Start				0	2483	0 = Start/Stop After Fault Reset 1 = Restart After Fault Reset
P6.2.3 ①②	4mA Input Fault				0	306	0 = No Action 1 = Warning 2 = Warning: Previous Freq 3 = Warning: Preset Freq 4 = Fault 5 = Fault, Coast
P6.2.4 ①②	4mA Fault Frequency	0.00	See Par ID 102	Hz	0.00	331	
P6.2.5 ①②	External Fault				2	307	See Par ID 308
P6.2.6 ①②	Input Phase Fault				2	332	See Par ID 308
P6.2.7 ①②	Uvolt Fault Response				2	330	See Par ID 308
P6.2.8 ①②	Unit Under Temp Prot				2	1564	See Par ID 308
P6.2.9 ①②	RTC Fault				1	955	See Par ID 308
P6.2.10 ①②	Replace Battery Fault Response				1	1256	See Par ID 308
P6.2.11 ①②	Replace Fan Fault Response				1	1257	See Par ID 308
P6.2.12 ②	Cold Weather Mode				0	2126	See Par ID 1346
P6.2.13 ②	Cold Weather Volt. Level	0.0	20.0	%	2.0	2127	
P6.2.14 ②	Cold Weather Time Out	0	10	min	3	2128	
P6.2.15	Cold Weather Password					2129	
P6.2.16	Under Temp Fault Override					2130	See Par ID 2118
P6.2.17 ②	STO Fault Response				2	2427	0 = No Action 1 = Warning 2 = Fault

Table 168. Communication — P6.3

Code	Parameter	Min.	Max.	Unit	Default	ID	Note
P6.3.1 ①②	Fieldbus Fault Response				2	334	0 = No Action 1 = Warning 2 = Fault 3 = Fault, Coast 4 = Warning, Coast
P6.3.2 ①②	OPTCard Fault Response				2	335	See Par ID 308
P6.3.3 ①②	IP Address Confliction Resp				1	1678	See Par ID 308
P6.3.4 ①②	Keypad Comm Fault Response				2	2157	See Par ID 308

Table 169. Auto Restart — P6.4

Code	Parameter	Min.	Max.	Unit	Default	ID	Note
P6.4.1 ②	AR Wait Time	1.00	300.00	s	1.00	321	
P6.4.2 ②	AR Trail Time	0.00	600.00	s	30.00	322	
P6.4.3 ②	AR Start Function				0	323	0 = Flying Start 1 = Ramp

Note: ① Parameter value can only be changed after the drive has stopped.
② Parameter value will be set to be default when changing macros.

Table 169. Auto Restart — P6.4, continued

Code	Parameter	Min.	Max.	Unit	Default	ID	Note
P6.4.4 ②	Undervoltage Attempts	0	10		1	324	
P6.4.5 ②	OverVoltage Attempts	0	10		1	325	
P6.4.6 ②	OverCurrent Attempts	0	3		1	326	
P6.4.7 ②	4mA Fault Attempts	0	10		1	327	
P6.4.8 ②	Motor Temp Fault Attempts	0	10		1	329	
P6.4.9 ②	External Fault Attempts	0	10		0	328	
P6.4.10 ②	Underload Attempts	0	10		1	336	

PID Controller 1

Table 170. Basic Setting — P7.1

Code	Parameter	Min.	Max.	Unit	Default	ID	Note
P7.1.1 ②	PID1 Control Gain	0.00	200.00	%	100.00	1294	
P7.1.2 ②	PID1 Control ITime	0.00	600.00	s	1.00	1295	
P7.1.3 ②	PID1 Control DTime	0.00	100.00	s	0.00	1296	
P7.1.4 ①②	PID1 Process Unit				0	1297	0 = % 1 = 1/min 2 = rpm 3 = ppm 4 = pps 5 = l/s 6 = l/min 7 = l/h 8 = kg/s 9 = kg/min 10 = kg/h 11 = m3/s 12 = m3/min 13 = m3/h 14 = m/s 15 = mbar 16 = bar 17 = Pa 18 = kPa 19 = mVS 20 = kW 21 = °C 22 = GPM 23 = gal/s 24 = gal/min 25 = gal/h 26 = lb/s 27 = lb/min 28 = lb/h 29 = CFM 30 = ft3/s 31 = ft3/min 32 = ft3/h 33 = ft/s 34 = in wg 35 = ft wg 36 = PSI 37 = lb/in2 38 = HP 39 = °F 40 = PA 41 = WC 42 = HG 43 = ft 44 = m

Note: ① Parameter value can only be changed after the drive has stopped.

② Parameter value will be set to be default when changing macros.

Table 170. Basic Setting — P7.1, continued

Code	Parameter	Min.	Max.	Unit	Default	ID	Note
P7.1.5 [ⓐ]	PID1 Process Unit Min	-99999.99	See Par ID 1300	Varies	0.00	1298	
P7.1.6 [ⓐ]	PID1 Process Unit Max	See Par ID 1298	99999.99	Varies	100.00	1300	
P7.1.7 [ⓐ]	PID1 Process Unit Decimal	0	4		2	1302	
P7.1.8 ^{ⓐⓑ}	PID1 Error Inversion				0	1303	See Par ID 181
P7.1.9 [ⓐ]	PID1 Dead Band	0.00	99999.99	Varies	0.00	1304	
P7.1.10 [ⓐ]	PID1 Dead Band Delay	0.00	320.00	s	0.00	1306	
P7.1.11 [ⓐ]	PID1 Ramp Time	0.00	300.00	s	0.00	1311	

Table 171. Monitor — P7.2

Code	Parameter	Min.	Max.	Unit	Default	ID	Note
P7.2.1	FB PID1 Set Point 1	See Par ID 1298	See Par ID 1300	Varies		2542	
P7.2.2	FB PID1 Set Point 2	See Par ID 1298	See Par ID 1300	Varies		2544	
P7.2.3	FB PID1 Feedback 1			%		2550	
P7.2.4	FB PID1 Feedback 2			%		2551	
P7.2.5	FB PID1 Feedforward 1			%		2554	
P7.2.6	FB PID1 Feedforward 2			%		2555	

Setpoint

Table 172. Basic — P7.3.1

Code	Parameter	Min.	Max.	Unit	Default	ID	Note
P7.3.1.1 [ⓐ]	PID1 Keypad Set Point 1	See Par ID 1298	See Par ID 1300	Varies	0.00	1307	
P7.3.1.2 [ⓐ]	PID1 Keypad Set Point 2	See Par ID 1298	See Par ID 1300	Varies	0.00	1309	
P7.3.1.3 [ⓐ]	PID1 Wake Up Action				0	2466	0 = Below Wake Up Level 1 = Above Wake Up Level 2 = Below Wake Up Level(PID ref.) Wake up when below wakeup level % set in Para ID 1318 or 1327 from PID Setpoint. 3 = Above Wake Up Level (PID ref.) Wake up when above wakeup level % set in Para ID 1318 or 1327 from PID Setpoint.

Note: [ⓐ] Parameter value can only be changed after the drive has stopped.
[ⓑ] Parameter value will be set to be default when changing macros.

Table 173. Setpoint 1 — P7.3.2

Code	Parameter	Min.	Max.	Unit	Default	ID	Note
P7.3.2.1 ①②	PID1 Set Point 1 Source				1	1312	0 = Not Used 1 = PID1 Keypad Set Point 1 2 = PID1 Keypad Set Point 2 3 = AI1 4 = AI2 5 = Slot A: AI1 6 = Slot B: AI1 7 = FB Process Data Input 1 8 = FB Process Data Input 2 9 = FB Process Data Input 3 10 = FB Process Data Input 4 11 = FB Process Data Input 5 12 = FB Process Data Input 6 13 = FB Process Data Input 7 14 = FB Process Data Input 8 15 = PID2 Output 16 = FB PID1 Set Point 1 17 = FB PID1 Set Point 2
P7.3.2.2 ②	PID1 Set Point 1 Min	-200.00	200.00	%	0.00	1313	
P7.3.2.3 ②	PID1 Set Point 1 Max	-200.00	200.00	%	100.00	1314	
P7.3.2.4 ①②	PID1 Set Point 1 Sleep Enable				0	1315	See Par ID 1346
P7.3.2.5 ①②	PID1 Set Point 1 Sleep Unit Sel				0	2396	0 = Output Frequency 1 = Motor Speed 2 = Motor Current 3 = PID1 Feedback
P7.3.2.6 ②	PID1 Set Point 1 Sleep Level			Varies	0.00	2450	
P7.3.2.7 ②	PID1 Set Point 1 Sleep Delay	0	3000	s	0	1317	
P7.3.2.8 ②	PID1 Set Point 1 Wake Up Level	-99999.99	99999.99	Varies	0.00	1318	
P7.3.2.9 ②	PID1 Set Point 1 Boost	-2.0	2.0		1.0	1320	
P7.3.2.10 ②	PID1 Set Point 1 Comp Enable				0	1352	See Par ID 1346
P7.3.2.11 ②	PID1 Set Point 1 Comp Max	-200.00	200.00	%	0.00	1353	

Table 174. Setpoint 2 — P7.3.3

Code	Parameter	Min.	Max.	Unit	Default	ID	Note
P7.3.3.1 ①②	PID1 Set Point 2 Source				2	1321	See Par ID 1312
P7.3.3.2 ②	PID1 Set Point 2 Min	-200.00	200.00	%	0.00	1322	
P7.3.3.3 ②	PID1 Set Point 2 Max	-200.00	200.00	%	100.00	1323	
P7.3.3.4 ①②	PID1 Set Point 2 Sleep Enable				0	1324	See Par ID 1346
P7.3.3.5 ①②	PID1 Set Point 2 Sleep Unit Sel				0	2397	See Par ID 2396
P7.3.3.6 ②	PID1 Set Point 2 Sleep Level			Varies	0.00	2452	
P7.3.3.7 ②	PID1 Set Point 2 Sleep Delay	0	3000	s	0	1326	
P7.3.3.8 ②	PID1 Set Point 2 Wake Up Level	-99999.99	99999.99	Varies	0.00	1327	
P7.3.3.9 ②	PID1 Set Point 2 Boost	-2.0	2.0		1.0	1329	
P7.3.3.10 ②	PID1 Set Point 2 Comp Enable				0	1354	See Par ID 1346
P7.3.3.11 ②	PID1 Set Point 2 Comp Max	-200.00	200.00	%	0.00	1355	

Note: ① Parameter value can only be changed after the drive has stopped.

② Parameter value will be set to be default when changing macros.

Feedback

Table 175. Basic — P7.4.1

Code	Parameter	Min.	Max.	Unit	Default	ID	Note
P7.4.1.1 ①②	PID1 Feedback Function				0	1330	0 = Source 1 1 = SQRT(Source 1) 2 = SQRT(Source 1 - Source 2) 3 = SQRT(Source 1) + SQRT(Source 2) 4 = Source 1 + Source 2 5 = Source 1 - Source 2 6 = MIN(Source 1,Source 2) 7 = MAX(Source 1,Source 2) 8 = MEAN(Source1,Source2)
P7.4.1.2 ②	PID1 Feedback Gain	-1000.0	1000.0	%	100.0	1331	

Table 176. Feedback 1 — P7.4.2

Code	Parameter	Min.	Max.	Unit	Default	ID	Note
P7.4.2.1 ①②	PID1 Feedback 1 Source				2	1332	0 = Not Used 1 = AI1 2 = AI2 3 = Slot A: AI1 4 = Slot B: AI1 5 = FB Process Data Input 1 6 = FB Process Data Input 2 7 = FB Process Data Input 3 8 = FB Process Data Input 4 9 = FB Process Data Input 5 10 = FB Process Data Input 6 11 = FB Process Data Input 7 12 = FB Process Data Input 8 13 = PT100 Temperature 14 = PID2 Output 15 = SlotA PT100 Temp Channel 1 16 = SlotA PT100 Temp Channel 2 17 = SlotA PT100 Temp Channel 3 18 = SlotB PT100 Temp Channel 1 19 = SlotB PT100 Temp Channel 2 20 = SlotB PT100 Temp Channel 3 21 = FB PID1 Feedback 1 22 = FB PID1 Feedback 2
P7.4.2.2 ②	PID1 Feedback 1 Min	-200.00	200.00	%	0.00	1333	
P7.4.2.3 ②	PID1 Feedback 1 Max	-200.00	200.00	%	100.00	1334	

Table 177. Feedback 2 — P7.4.3

Code	Parameter	Min.	Max.	Unit	Default	ID	Note
P7.4.3.1 ①②	PID1 Feedback 2 Source				0	1335	See Par ID 1332
P7.4.3.2 ②	PID1 Feedback 2 Min	-200.00	200.00	%	0.00	1336	
P7.4.3.3 ②	PID1 Feedback 2 Max	-200.00	200.00	%	100.00	1337	

Feedforward

Table 178. Basic — P7.5.1

Code	Parameter	Min.	Max.	Unit	Default	ID	Note
P7.5.1.1 ①②	PID1 Feedforward Func				0	1338	See Par ID 1330
P7.5.1.2 ②	PID1 Feedforward Gain	-1000.0	1000.0	%	100.0	1339	

Note: ① Parameter value can only be changed after the drive has stopped.
② Parameter value will be set to be default when changing macros.

Table 179. Feedforward 1 — P7.5.2

Code	Parameter	Min.	Max.	Unit	Default	ID	Note
P7.5.2.1 ①②	PID1 Feedforward 1 Source				0	1340	0 = Not Used 1 = AI1 2 = AI2 3 = Slot A: AI1 4 = Slot B: AI1 5 = FB Process Data Input 1 6 = FB Process Data Input 2 7 = FB Process Data Input 3 8 = FB Process Data Input 4 9 = FB Process Data Input 5 10 = FB Process Data Input 6 11 = FB Process Data Input 7 12 = FB Process Data Input 8 13 = PT100 Temperature 14 = PID2 Output 15 = SlotA PT100 Temp Channel 1 16 = SlotA PT100 Temp Channel 2 17 = SlotA PT100 Temp Channel 3 18 = SlotB PT100 Temp Channel 1 19 = SlotB PT100 Temp Channel 2 20 = SlotB PT100 Temp Channel 3 21 = FB PID1 Feedforward 1 22 = FB PID1 Feedforward 2
P7.5.2.2 ②	PID1 Feedforward 1 Min	-200.00	200.00	%	0.00	1341	
P7.5.2.3 ②	PID1 Feedforward 1 Max	-200.00	200.00	%	100.00	1342	

Table 180. Feedforward 2 — P7.5.3

Code	Parameter	Min.	Max.	Unit	Default	ID	Note
P7.5.3.1 ①②	PID1 Feedforward 2 Source				0	1343	See Par ID 1340
P7.5.3.2 ②	PID1 Feedforward 2 Min	-200.00	200.00	%	0.00	1344	
P7.5.3.3 ②	PID1 Feedforward 2 Max	-200.00	200.00	%	100.00	1345	

PID Controller 2

Table 181. Basic Setting — P8.1

Code	Parameter	Min.	Max.	Unit	Default	ID	Note
P8.1.1 ②	PID2 Control Gain	0.00	200.00	%	100.00	1356	
P8.1.2 ②	PID2 Control I Time	0.00	600.00	s	1.00	1357	
P8.1.3 ②	PID2 Control D Time	0.00	100.00	s	0.00	1358	
P8.1.4 ①②	PID2 Process Unit				0	1359	See Par ID 1297
P8.1.5 ②	PID2 Process Unit Min	-99999.99	See Par ID 1362	Varies	0.00	1360	
P8.1.6 ②	PID2 Process Unit Max	See Par ID 1360	99999.99	Varies	100.00	1362	
P8.1.7 ②	PID2 Process Unit Decimal	0	4		2	1364	
P8.1.8 ①②	PID2 Error Inversion				0	1365	See Par ID 181
P8.1.9 ②	PID2 Dead Band	0.00	99999.99	Varies	0.00	1366	
P8.1.10 ②	PID2 Dead Band Delay	0.00	320.00	s	0.00	1368	
P8.1.11 ②	PID2 Ramp Time	0.00	300.00	s	0.00	1373	

Note: ① Parameter value can only be changed after the drive has stopped.

② Parameter value will be set to be default when changing macros.

Chapter 7—Advanced application parameter

Table 182. Monitor — P8.2

Code	Parameter	Min.	Max.	Unit	Default	ID	Note
P8.2.1 ②	PID2 Wake Up Action				0	2467	See Par ID 2466
P8.2.2	FB PID2 Set Point 1	See Par ID 1298	See Par ID 1300	Varies		2546	
P8.2.3	FB PID2 Set Point 2	See Par ID 1298	See Par ID 1300	Varies		2548	
P8.2.4	FB PID2 Feedback 1			%		2552	
P8.2.5	FB PID2 Feedback 2			%		2553	
P8.2.6	FB PID2 Feedforward 1			%		2556	
P8.2.7	FB PID2 Feedforward 2			%		2557	

Setpoint

Table 183. Basic — P8.3.1

Code	Parameter	Min.	Max.	Unit	Default	ID	Note
P8.3.1.1 ②	PID2 Keypad Set Point 1	See Par ID 1360	See Par ID 1362	Varies	0.00	1369	
P8.3.1.2 ②	PID2 Keypad Set Point 2	See Par ID 1360	See Par ID 1362	Varies	0.00	1371	
P8.3.1.3 ②	PID2 Wake Up Action				0	2467	See Par ID 2466

Table 184. Setpoint 1 — P8.3.2

Code	Parameter	Min.	Max.	Unit	Default	ID	Note
P8.3.2.1 ①②	PID2 Set Point 1 Source				1	1374	0 = Not Used 1 = PID2 Keypad Set Point 1 2 = PID2 Keypad Set Point 2 3 = AI1 4 = AI2 5 = Slot A: AI1 6 = Slot B: AI1 7 = FB Process Data Input 1 8 = FB Process Data Input 2 9 = FB Process Data Input 3 10 = FB Process Data Input 4 11 = FB Process Data Input 5 12 = FB Process Data Input 6 13 = FB Process Data Input 7 14 = FB Process Data Input 8 15 = PID1 Output 16 = FB PID2 Set Point 1 17 = FB PID2 Set Point 2
P8.3.2.2 ②	PID2 Set Point 1 Min	-200.00	200.00	%	0.00	1375	
P8.3.2.3 ②	PID2 Set Point 1 Max	-200.00	200.00	%	100.00	1376	
P8.3.2.4 ①②	PID2 Set Point 1 Sleep Enable				0	1377	See Par ID 1346
P8.3.2.5 ①②	PID2 Set Point 1 Sleep Unit Sel				0	2398	0 = Output Frequency 1 = Motor Speed 2 = Motor Current 3 = PID2 Feedback
P8.3.2.6 ②	PID2 Set Point 1 Sleep Level			Varies	0.00	2454	
P8.3.2.7 ②	PID2 Set Point 1 Sleep Delay	0	3000	s	0	1379	
P8.3.2.8 ②	PID2 Set Point 1 WakeUp Level	-99999.99	99999.99	Varies	0.00	1380	
P8.3.2.9 ②	PID2 Set Point 1 Boost	-2.0	2.0		1.0	1382	
P8.3.2.10 ②	PID2 Set Point1 Comp Enable				0	1414	See Par ID 1346
P8.3.2.11 ②	PID2 Set Point1 Comp Max	-200.00	200.00	%	0.00	1415	
P8.3.2.12	FB PID2 Set Point 1	See Par ID 1298	See Par ID 1300	Varies		2546	

Note: ① Parameter value can only be changed after the drive has stopped.

② Parameter value will be set to be default when changing macros.

Table 185. Setpoint 2 — P8.3.3

Code	Parameter	Min.	Max.	Unit	Default	ID	Note
P8.3.3.1 ①②	PID2 Set Point 2 Source				2	1383	See Par ID 1374
P8.3.3.2 ②	PID2 Set Point 2 Min	-200.00	200.00	%	0.00	1384	
P8.3.3.3 ②	PID2 Set Point 2 Max	-200.00	200.00	%	100.00	1385	
P8.3.3.4 ①②	PID2 Set Point 2 Sleep Enable				0	1386	See Par ID 1346
P8.3.3.5 ①②	PID2 Set Point 2 Sleep Unit Sel				0	2399	See Par ID 2398
P8.3.3.6 ②	PID2 Set Point 2 Sleep Level			Varies	0.00	2456	
P8.3.3.7 ②	PID2 Set Point 2 Sleep Delay	0	3000	s	0	1388	
P8.3.3.8 ②	PID2 Set Point 2 WakeUp Level	-99999.99	99999.99	Varies	0.00	1389	
P8.3.3.9 ②	PID2 Set Point 2 Boost	-2.0	2.0		1.0	1391	
P8.3.3.10 ②	PID2 Set Point 2 Comp Enable				0	1416	See Par ID 1346
P8.3.3.11 ②	PID2 Set Point 2 Comp Max	-200.00	200.00	%	0.00	1417	
P8.3.3.12	FB PID2 Set Point 2	See Par ID 1298	See Par ID 1300	Varies		2548	

Feedback

Table 186. Basic — P8.4.1

Code	Parameter	Min.	Max.	Unit	Default	ID	Note
P8.4.1.1 ①②	PID2 Feedback Func				0	1392	See Par ID 1330
P8.4.1.2 ②	PID2 Feedback Gain	-1000.0	1000.0	%	100.0	1393	

Table 187. Feedback 1 — P8.4.2

Code	Parameter	Min.	Max.	Unit	Default	ID	Note
P8.4.2.1 ①②	PID2 Feedback 1 Source				2	1394	0 = Not Used 1 = AI1 2 = AI2 3 = Slot A: AI1 4 = Slot B: AI1 5 = FB Process Data Input 1 6 = FB Process Data Input 2 7 = FB Process Data Input 3 8 = FB Process Data Input 4 9 = FB Process Data Input 5 10 = FB Process Data Input 6 11 = FB Process Data Input 7 12 = FB Process Data Input 8 13 = PT100 Temperature 14 = PID1 Output 15 = SlotA PT100 Temp Channel 1 16 = SlotA PT100 Temp Channel 2 17 = SlotA PT100 Temp Channel 3 18 = SlotB PT100 Temp Channel 1 19 = SlotB PT100 Temp Channel 2 20 = SlotB PT100 Temp Channel 3 21 = FB PID2 Feedback 1 22 = FB PID2 Feedback 2
P8.4.2.2 ②	PID2 Feedback 1 Min	-200.00	200.00	%	0.00	1395	
P8.4.2.3 ②	PID2 Feedback 1 Max	-200.00	200.00	%	100.00	1396	
P8.4.2.4	FB PID2 Feedback 1			%		2552	

Table 188. Feedback 2 — P8.4.3

Code	Parameter	Min.	Max.	Unit	Default	ID	Note
P8.4.3.1 ①②	PID2 Feedback 2 Source				0	1397	See Par ID 1394
P8.4.3.2 ②	PID2 Feedback 2 Min	-200.00	200.00	%	0.00	1398	
P8.4.3.3 ②	PID2 Feedback 2 Max	-200.00	200.00	%	100.00	1399	
P8.4.3.4	FB PID2 Feedback 2			%		2553	

Note: ① Parameter value can only be changed after the drive has stopped.

② Parameter value will be set to be default when changing macros.

Feedforward

Table 189. Basic — P8.5.1

Code	Parameter	Min.	Max.	Unit	Default	ID	Note
P8.5.1.1 ①②	PID2 Feedforward Func				0	1400	See Par ID 1330
P8.5.1.2 ②	PID2 Feedforward Gain	-1000.0	1000.0	%	100.0	1401	

Table 190. Feedforward 1 — P8.5.2

Code	Parameter	Min.	Max.	Unit	Default	ID	Note
P8.5.2.1 ①②	PID2 Feedforward 1 Source				0	1402	0 = Not Used 1 = AI1 2 = AI2 3 = Slot A: AI1 4 = Slot B: AI1 5 = FB Process Data Input 1 6 = FB Process Data Input 2 7 = FB Process Data Input 3 8 = FB Process Data Input 4 9 = FB Process Data Input 5 10 = FB Process Data Input 6 11 = FB Process Data Input 7 12 = FB Process Data Input 8 13 = PT100 Temperature 14 = PID1 Output 15 = SlotA PT100 Temp Channel 1 16 = SlotA PT100 Temp Channel 2 17 = SlotA PT100 Temp Channel 3 18 = SlotB PT100 Temp Channel 1 19 = SlotB PT100 Temp Channel 2 20 = SlotB PT100 Temp Channel 3 21 = FB PID2 Feedforward 1 22 = FB PID2 Feedforward 2
P8.5.2.2 ②	PID2 Feedforward 1 Min	-200.00	200.00	%	0.00	1403	
P8.5.2.3 ②	PID2 Feedforward 1 Max	-200.00	200.00	%	100.00	1404	
P8.5.2.4	FB PID2 Feedforward 1			%		2556	

Table 191. Feedforward 2 — P8.5.3

Code	Parameter	Min.	Max.	Unit	Default	ID	Note
P8.5.3.1 ①②	PID2 Feedforward 2 Source				0	1405	See Par ID 1402
P8.5.3.2 ②	PID2 Feedforward 2 Min	-200.00	200.00	%	0.00	1406	
P8.5.3.3 ②	PID2 Feedforward 2 Max	-200.00	200.00	%	100.00	1407	
P8.5.3.4	FB PID2 Feedforward 2			%		2557	

Table 192. Fire Mode — P9

Code	Parameter	Min.	Max.	Unit	Default	ID	Note
P9.1 ①②	Fire Mode Function				0	535	0 = Closing Contact 1 = Opening Contact
P9.2 ①②	Fire Mode Ref Select Function				0	536	0 = Fire Mode Min Frequency 1 = Fire Mode Ref 2 = Fieldbus Ref 3 = AI1 4 = AI2 5 = AI1 + AI2 6 = PID1 Control Output 7 = PID2 Control Output
P9.3 ②	Fire Mode Min Frequency	See Par ID 101	See Par ID 102	Hz	15.00	537	
P9.4 ②	Fire Mode Freq Ref 1	0.0	100.0	%	75.0	565	
P9.5 ②	Fire Mode Freq Ref 2	0.0	100.0	%	100.0	564	
P9.6	Fire Mode Test Enable					2443	See Par ID 1346
P9.7 ①②	Smoke Purge Frequency	0.0	100.0	%	50.0	554	

Note: ① Parameter value can only be changed after the drive has stopped.

② Parameter value will be set to be default when changing macros.

Bypass

Table 193. Basic Setting — P10.1

Code	Parameter	Min.	Max.	Unit	Default	ID	Note
P10.1.1 ①②	Bypass Enable				1	1418	See Par ID 1346
P10.1.2 ①②	Bypass Start Delay	1	32765	s	1	544	
P10.1.3 ①②	Auto Bypass				1	542	See Par ID 1346
P10.1.4 ①②	Auto Bypass Delay	0	32765	s	10	543	
P10.1.5 ①②	OverCurrent Bypass Enable				1	547	See Par ID 1346
P10.1.6 ①②	IGBT Fault Bypass Enable				1	546	See Par ID 1346
P10.1.7 ①②	4mA Fault Bypass Enable				1	548	See Par ID 1346
P10.1.8 ①②	UnderVoltage Bypass Enable				1	545	See Par ID 1346
P10.1.9 ①②	OverVoltage Bypass Enable				1	549	See Par ID 1346
P10.1.10 ①②	Motor OverTemp Bypass Enable				1	1698	See Par ID 1346
P10.1.11 ①②	UnderLoad Bypass Enable				1	1699	See Par ID 1346
P10.1.12 ①②	External Bypass Enable				1	1700	See Par ID 1346
P10.1.13 ①②	Charge Switch Fault Bypass Enable				1	1701	See Par ID 1346
P10.1.14 ①②	Saturation Trip Fault Bypass Enable				1	1702	See Par ID 1346
P10.1.15 ①②	Under Temp Fault Bypass Enable				1	1703	See Par ID 1346
P10.1.16 ①②	EEPROM Fault Bypass Enable				1	1704	See Par ID 1346
P10.1.17 ①②	FRAM Fault Bypass Enable				1	1705	See Par ID 1346
P10.1.18 ①②	Watchdog Fault Bypass Enable				1	1706	See Par ID 1346
P10.1.19 ①②	Fan Cooling Fault Bypass Enable				1	1707	See Par ID 1346
P10.1.20 ①②	Keypad Com Fault Bypass Enable				1	1708	See Par ID 1346
P10.1.21 ①②	Option Card Fault Bypass Enable				1	1709	See Par ID 1346
P10.1.22 ①②	RTC Clock Fault Bypass Enable				1	1710	See Par ID 1346
P10.1.23 ①②	Ctrl Board OverTemp Fault Bypass Enable				1	1711	See Par ID 1346
P10.1.24 ①②	Speed Search Start Fault Bypass Enable				1	1712	See Par ID 1346
P10.1.25 ①②	Fieldbus Fault Bypass Enable				1	1713	See Par ID 1346

Table 194. Redundant Drive — P10.2

Code	Parameter	Min.	Max.	Unit	Default	ID	Note
P10.2.1 ①②	Redundant Drive Enable				0	2476	See Par ID 1346
P10.2.2 ①②	Drive ID	0	5		0	2278	
P10.2.3 ②	Redundant Run Time Enable				0	2477	See Par ID 1346
P10.2.4	Redundant Run Time Reset					2478	See Par ID 2125
P10.2.5 ②	Redundant RunTime Limit	0.0	300000.0	h	0.0	2479	

Real Time Clock

Table 195. Interval 1 — P11.1

Code	Parameter	Min.	Max.	Unit	Default	ID	Note
P11.1.1 ②	Interval 1 Setting				0	2487	0 = Weekly 1 = Daily
P11.1.2 ②	Interval 1 On Time				0	491	
P11.1.3 ②	Interval 1 Off Time				0	493	

Note: ① Parameter value can only be changed after the drive has stopped.

② Parameter value will be set to be default when changing macros.

Table 195. Interval 1 — P11.1, continued

Code	Parameter	Min.	Max.	Unit	Default	ID	Note
P11.1.4 [ⓐ]	Interval 1 From Day				0	517	0 = Sunday 1 = Monday 2 = Tuesday 3 = Wednesday 4 = Thursday 5 = Friday 6 = Saturday
P11.1.5 [ⓐ]	Interval 1 To Day				0	518	See Par ID 517
P11.1.6 [ⓐ]	Interval 1 Channel				0	519	0 = Not Used 1 = Time Channel 1 2 = Time Channel 2 3 = Time Channel 3

Table 196. Interval 2 — P11.2

Code	Parameter	Min.	Max.	Unit	Default	ID	Note
P11.2.1 [ⓐ]	Interval 2 Setting				0	2488	See Par ID 2487
P11.2.2 [ⓐ]	Interval 2 On Time				0	495	
P11.2.3 [ⓐ]	Interval 2 Off Time				0	497	
P11.2.4 [ⓐ]	Interval 2 From Day				0	520	See Par ID 517
P11.2.5 [ⓐ]	Interval 2 To Day				0	521	See Par ID 517
P11.2.6 [ⓐ]	Interval 2 Channel				0	522	See Par ID 519

Table 197. Interval 3 — P11.3

Code	Parameter	Min.	Max.	Unit	Default	ID	Note
P11.3.1 [ⓐ]	Interval 3 Setting				0	2489	See Par ID 2487
P11.3.2 [ⓐ]	Interval 3 On Time				0	499	
P11.3.3 [ⓐ]	Interval 3 Off Time				0	501	
P11.3.4 [ⓐ]	Interval 3 From Day				0	523	See Par ID 517
P11.3.5 [ⓐ]	Interval 3 To Day				0	524	See Par ID 517
P11.3.6 [ⓐ]	Interval 3 Channel				0	525	See Par ID 519

Table 198. Interval 4 — P11.4

Code	Parameter	Min.	Max.	Unit	Default	ID	Note
P11.4.1 [ⓐ]	Interval 4 Setting				0	2490	See Par ID 2487
P11.4.2 [ⓐ]	Interval 4 On Time				0	503	
P11.4.3 [ⓐ]	Interval 4 Off Time				0	505	
P11.4.4 [ⓐ]	Interval 4 From Day				0	526	See Par ID 517
P11.4.5 [ⓐ]	Interval 4 To Day				0	527	See Par ID 517
P11.4.6 [ⓐ]	Interval 4 Channel				0	528	See Par ID 519

Table 199. Interval 5 — P11.5

Code	Parameter	Min.	Max.	Unit	Default	ID	Note
P11.5.1 [ⓐ]	Interval 5 Setting				0	2491	See Par ID 2487
P11.5.2 [ⓐ]	Interval 5 On Time				0	507	
P11.5.3 [ⓐ]	Interval 5 Off Time				0	509	
P11.5.4 [ⓐ]	Interval 5 From Day				0	529	See Par ID 517
P11.5.5 [ⓐ]	Interval 5 To Day				0	530	See Par ID 517
P11.5.6 [ⓐ]	Interval 5 Channel				0	531	See Par ID 519

Note: [ⓐ] Parameter value can only be changed after the drive has stopped.
[ⓑ] Parameter value will be set to be default when changing macros.

Table 200. Timer — P11.6

Code	Parameter	Min.	Max.	Unit	Default	ID	Note
P11.6.1 [Ⓢ]	Timer 1 Duration	0	72000	s	0	511	
P11.6.2 [Ⓢ]	Timer 1 Channel				0	532	See Par ID 519
P11.6.3 [Ⓢ]	Timer 2 Duration	0	72000	s	0	513	
P11.6.4 [Ⓢ]	Timer 2 Channel				0	533	See Par ID 519
P11.6.5 [Ⓢ]	Timer 3 Duration	0	72000	s	0	515	
P11.6.6 [Ⓢ]	Timer 3 Channel				0	534	See Par ID 519

Communication

Table 201. FB Process Data Input Sel — P12.1

Code	Parameter	Min.	Max.	Unit	Default	ID	Note
P12.1.1 [Ⓢ]	FB Process Data Input 1 Sel	0	2560		0	2533	
P12.1.2 [Ⓢ]	FB Process Data Input 2 Sel	0	2560		2542	2534	
P12.1.3 [Ⓢ]	FB Process Data Input 3 Sel	0	2560		2550	2535	
P12.1.4 [Ⓢ]	FB Process Data Input 4 Sel	0	2560		103	2536	
P12.1.5 [Ⓢ]	FB Process Data Input 5 Sel	0	2560		104	2537	
P12.1.6 [Ⓢ]	FB Process Data Input 6 Sel	0	2560		107	2538	
P12.1.7 [Ⓢ]	FB Process Data Input 7 Sel	0	2560		0	2539	
P12.1.8 [Ⓢ]	FB Process Data Input 8 Sel	0	2560		0	2540	

Table 202. FB Process Data Output Sel — P12.2

Code	Parameter	Min.	Max.	Unit	Default	ID	Note
P12.2.1 [Ⓢ]	FB Process Data Output 1 Sel				1	1556	
P12.2.2 [Ⓢ]	FB Process Data Output 2 Sel				2	1557	
P12.2.3 [Ⓢ]	FB Process Data Output 3 Sel				3	1558	
P12.2.4 [Ⓢ]	FB Process Data Output 4 Sel				4	1559	
P12.2.5 [Ⓢ]	FB Process Data Output 5 Sel				5	1560	
P12.2.6 [Ⓢ]	FB Process Data Output 6 Sel				6	1561	
P12.2.7 [Ⓢ]	FB Process Data Output 7 Sel				7	1562	
P12.2.8 [Ⓢ]	FB Process Data Output 8 Sel				28	1563	
P12.2.9 [Ⓢ]	Standard Status Word Bit0 Function Select				1	2415	0 = Not Used 1 = Ready 2 = Run 3 = Fault 4 = Fault Invert 5 = Warning 6 = Reversed 7 = At Speed 8 = Zero Frequency 9 = Freq Limit 1 Superv 10 = Freq Limit 2 Superv 11 = PID1 Superv 12 = PID2 Superv 13 = OverHeat Fault 14 = OverCurrent Regular 15 = OverVoltage Regular 16 = UnderVoltage Regular 17 = 4mA Ref Fault/Warning 20 = Torq Limit Superv 21 = Ref Limit Superv 22 = Control from I/O 23 = Un-Requested Rotation Direction 24 = Thermistor Fault Output 25 = Fire Mode

Note: [Ⓢ] Parameter value can only be changed after the drive has stopped.

[Ⓢ] Parameter value will be set to be default when changing macros.

Table 202. FB Process Data Output Sel — P12.2, continued

Code	Parameter	Min.	Max.	Unit	Default	ID	Note
P12.2.9 ②	Standard Status Word Bit0 Function Select (cont.)				1	2415	26 = In Bypass Mode 27 = Ext Fault/Warning 28 = Auto Control 29 = Jog Speed Select 30 = Motor Therm Protection 31 = FB Digital Input 1 32 = FB Digital Input 2 33 = FB Digital Input 3 34 = FB Digital Input 4 35 = Damper Control 36 = TC1 Status 37 = TC2 Status 38 = TC3 Status 40 = Power Limit Superv 41 = Temp Limit Superv 42 = Analog Input Superv 43 = Motor 1 Control 48 = Logic Fulfilled 49 = PID1 Sleep 50 = PID2 Sleep 51 = Motor Current 1 Supv 52 = Motor Current 2 Supv 53 = Second AI Limit Supv 54 = DC Charge Switch Close 55 = Preheat Active 56 = Cold Weather Active 58 = 2th Stage Ramp Frequency Active 59 = STO Fault Output 60 = Run Bypass/Drive 61 = Bypass Overload 62 = Bypass Run
P12.2.10 ②	Standard Status Word Bit1 Function Select				2	2416	See Par ID 2415
P12.2.11 ②	Standard Status Word Bit2 Function Select				3	2417	See Par ID 2415
P12.2.12 ②	Standard Status Word Bit3 Function Select				4	2418	See Par ID 2415
P12.2.13 ②	Standard Status Word Bit4 Function Select				5	2419	See Par ID 2415
P12.2.14 ②	Standard Status Word Bit5 Function Select				6	2420	See Par ID 2415
P12.2.15 ②	Standard Status Word Bit6 Function Select				7	2421	See Par ID 2415
P12.2.16 ②	Standard Status Word Bit7 Function Select				8	2422	See Par ID 2415

RS485 Bus

Table 203. Basic Setting — P12.3.1

Code	Parameter	Min.	Max.	Unit	Default	ID	Note
P12.3.1.1 ①	RS485 Comm Set				0	586	0 = Modbus RTU 1 = BACnet MS/TP 2 = SA Bus

Table 204. Modbus RTU — P12.3.2

Code	Parameter	Min.	Max.	Unit	Default	ID	Note
P12.3.2.1 ①	Slave Address	1	247		1	587	
P12.3.2.2 ①	Baud Rate				1	584	0 = 9600 1 = 19200 2 = 38400 3 = 57600 4 = 115200

Note: ① Parameter value can only be changed after the drive has stopped.

② Parameter value will be set to be default when changing macros.

Table 204. Modbus RTU — P12.3.2, continued

Code	Parameter	Min.	Max.	Unit	Default	ID	Note
P12.3.2.3 ④	Parity Type				2	585	0 = None 1 = Odd 2 = Even
P12.3.2.4	Modbus RTU Protocol Status					588	0 = Initial 1 = Stopped 2 = Operational 3 = Faulted
P12.3.2.5	Comm Timeout Modbus RTU	0	60000	ms	10000	593	
P12.3.2.6	Modbus RTU Fault Response				0	2516	0 = in Fieldbus Control 1 = in all Control

Table 205. BACnet MS/TP — P12.3.3

Code	Parameter	Min.	Max.	Unit	Default	ID	Note
P12.3.3.1 ①	MSTP Baud Rate				2	594	0 = 9600 1 = 19200 2 = 38400 3 = 76800 4 = 115200
P12.3.3.2 ①	MSTP Device Address	0	127		1	595	
P12.3.3.3 ①	MSTP Instance Number	0	4194302		Varies	596	
P12.3.3.4	MSTP Comm Timeout	0	60000	ms	10000	598	
P12.3.3.5	MSTP Protocol Status					599	0 = Stopped 1 = Operational 2 = Faulted
P12.3.3.6	MSTP Fault Code					600	0 = None 1 = Sole Master
P12.3.3.7 ②	MSTP Fault Response				0	2526	See Par ID 2516
P12.3.3.8 ①	MSTP Max Master				127	1537	

Table 206. SA Bus — P12.3.4

Code	Parameter	Min.	Max.	Unit	Default	ID	Note
P12.3.4.1 ①②	SA Bus Baud Rate				2	1727	See Par ID 584
P12.3.4.2 ①②	SA Bus Device Address	204	254		204	1726	
P12.3.4.3 ①②	SA Bus Instance Number	0	4194302		0	1728	
P12.3.4.4 ①	SA Bus Comm Timeout	0	60000		10000	1730	
P12.3.4.5	SA Bus Protocol Status					1731	See Par ID 599
P12.3.4.6 ①	SA Bus Fault Response				0	1732	See Par ID 2516

EtherNet Bus

Table 207. Basic Setting — P12.4.1

Code	Parameter	Min.	Max.	Unit	Default	ID	Note
P12.4.1.1 ①	IP Address Mode				1	1500	0 = Static IP 1 = DHCP with AutoIP
P12.4.1.2	Active IP Address					1507	
P12.4.1.3	Active Subnet Mask					1509	
P12.4.1.4	Active Default Gateway					1511	
P12.4.1.5	MAC Address					1513	
P12.4.1.6 ①	Static IP Address				192.168.1.254	1501	
P12.4.1.7 ①	Static Subnet Mask				255.255.255.0	1503	
P12.4.1.8 ①	Static Default Gateway				192.168.1.1	1505	
P12.4.1.9 ①	Enable BACnetIP				0	1725	See Par ID 1346

Note: ① Parameter value can only be changed after the drive has stopped.

② Parameter value will be set to be default when changing macros.

Chapter 7—Advanced application parameter

Table 208. Modbus TCP — P12.4.2

Code	Parameter	Min.	Max.	Unit	Default	ID	Note
P12.4.2.1	Connection Limit				5	609	
P12.4.2.2	Modbus TCP Unit ID				1	610	
P12.4.2.3	Comm Timeout Modbus TCP	0	60000	ms	10000	611	
P12.4.2.4	Modbus TCP Protocol Status					612	See Par ID 599
P12.4.2.5	Modbus TCP Fault Response				0	2517	See Par ID 2516

Table 209. BACnet IP — P12.4.3

Code	Parameter	Min.	Max.	Unit	Default	ID	Note
P12.4.3.1 ①②	BACnet IP UDP port number				47808	1733	47808 = BAC0 47809 = BAC1 47810 = BAC2 47811 = BAC3 47812 = BAC4 47813 = BAC5 47814 = BAC6 47815 = BAC7 47816 = BAC8 47817 = BAC9 47818 = BACA 47819 = BACB 47820 = BACC 47821 = BACD 47822 = BACE 47823 = BACF
P12.4.3.2 ②	BACnet IP Foreign Device				0	1734	See Par ID 1346
P12.4.3.3 ②	BACnet IP BBMD IP				0.0.0.0	1735	
P12.4.3.4 ②	BACnet IP BBMD Port				47808	1737	See Par ID 1733
P12.4.3.5 ②	BACnet IP Registration Interval	0	65535		10	1738	
P12.4.3.6 ②	BACnet IP Comm Timeout	0	60000		0	1739	
P12.4.3.7	BACnet IP Protocol Status					1740	See Par ID 599
P12.4.3.8 ②	BACnet IP Fault Behavior				0	1741	See Par ID 2516
P12.4.3.9 ②	BACnetIP Instance Number	0	4194302		Varies	1742	

Note: ① Parameter value can only be changed after the drive has stopped.

② Parameter value will be set to be default when changing macros.

System

Table 210. Basic Setting — P13.1

Code	Parameter	Min.	Max.	Unit	Default	ID	Note
P13.1.1	Language				0	340	0 = English 1 = 中文 2 = Deutsch
P13.1.2 ①	Application					142	0 = Basic 1 = PID 2 = Advanced
P13.1.3 ①	Parameter Sets					619	0 = No 1 = Reload Defaults 2 = Reload Set 1 3 = Reload Set 2 4 = Store Set 1 5 = Store Set 2 6 = Reset 7 = Reload Defaults VM
P13.1.4	Up To Keypad					620	See Par ID 2118
P13.1.5 ①	Down From Keypad					621	0 = No 1 = All Parameters 2 = All, No Motor 3 = App Parameters
P13.1.6	Parameter Comparison					623	0 = No 1 = Compare with Keypad 2 = Compare with Default 3 = Compare with Set 1 4 = Compare with Set 2
P13.1.7	Password	0	9999		0	624	
P13.1.8	Parameter Lock				0	625	0 = Change Enable 1 = Change Disable
P13.1.9	Multimonitor Set				0	627	See Par ID 625
P13.1.10	Default Page				0	628	0 = None 1 = Main Menu 2 = Multi-Monitor 3 = Favorite Menu 4 = Keypad Reference
P13.1.11	Timeout Time	0	65535	s	30	629	
P13.1.12	Contrast Adjust	5	18		12	630	
P13.1.13	Backlight Time	1	65535	min	10	631	
P13.1.14	Fan Control				2	632	0 = Continuous 1 = Temperature 2 = Run Follow 3 = Calculate IGBT Temp
P13.1.15	Keypad ACK Timeout	200	5000	ms	200	633	
P13.1.16	Keypad Retry Number	1	10		5	634	
P13.1.17	Startup Wizard				0	626	0 = Yes 1 = No
P13.1.18 ②	Jog Softkey Hidden				0	2412	See Par ID 1346
P13.1.19 ②	Reverse Softkey Hidden				0	2413	See Par ID 1346

Note: ① Parameter value can only be changed after the drive has stopped.

② Parameter value will be set to be default when changing macros.

Table 210 Basic Setting — P13.1, continued

Code	Parameter	Min.	Max.	Unit	Default	ID	Note
P13.1.20 ②	Output Display Unit				45	2424	0 = % 1 = 1/min 2 = rpm 3 = ppm 4 = pps 5 = l/s 6 = l/min 7 = l/h 8 = kg/s 9 = kg/min 10 = kg/h 11 = m3/s 12 = m3/min 13 = m3/h 14 = m/s 15 = mbar 16 = bar 17 = Pa 18 = kPa 19 = mVS 20 = kW 21 = °C 22 = GPM 23 = gal/s 24 = gal/min 25 = gal/h 26 = lb/s 27 = lb/min 28 = lb/h 29 = CFM 30 = ft3/s 31 = ft3/min 32 = ft3/h 33 = ft/s 34 = in wg 35 = ft wg 36 = PSI 37 = lb/in2 38 = HP 39 = ∅ 40 = PA 41 = WC 42 = HG 43 = ft 44 = m 45 = Hz 46 = strokes/min
P13.1.21 ②	Output Display Unit Min	-60000.00	See Par ID 2425	Varies	0.00	2460	
P13.1.22 ②	Output Display Unit Max	See Par ID 2460	60000.00	Varies	Varies	2425	

Table 211. Version Info — P13.2

Code	Parameter	Min.	Max.	Unit	Default	ID	Note
P13.2.1	Keypad Software Version					640	
P13.2.2	Motor Control Software Version					642	
P13.2.3	Application Software Version					644	
P13.2.4	Software Bundle Version					1714	

- Note:**
- ① Parameter value can only be changed after the drive has stopped.
 - ② Parameter value will be set to be default when changing macros.
 - ③ Input function is level sensed.
 - ④ Input function is edge sensed.
 - ⑤ Input function is edge sensed when using StartP/StopP start logic.

Table 212. Application Info — P13.3

Code	Parameter	Min.	Max.	Unit	Default	ID	Note
P13.3.1	Brake Chopper					646	See Par ID 2118
P13.3.2	Brake Resistor Status					647	See Par ID 2118
P13.3.3	Serial Number					648	

Table 213. User Info — P13.4

Code	Parameter	Min.	Max.	Unit	Default	ID	Note
P13.4.1	Real Time Clock				0.0.0.1:1:13	566	
P13.4.2	Daylight Saving				0	582	0 = Off 1 = EU 2 = US
P13.4.3	Total MWh Count			Mwh		601	
P13.4.4	Total Power Day Count					603	
P13.4.5	Total Power Hr Count					606	
P13.4.6	Trip MWh Count			Mwh		604	
P13.4.7	Clear Trip MWh Count					635	See Par ID 2125
P13.4.8	Trip Power Day Count					636	
P13.4.9	Trip Power Hr Count					637	
P13.4.10	Clear Trip Power Count					639	See Par ID 2125

Table 214. Operate Mode - O

Code	Parameter	Min.	Max.	Unit	Default	ID	Note
O1	Output Frequency			Hz		1	
O2	Freq Reference			Hz		24	
O3	Motor Speed			rpm		2	
O4	Motor Current			A		3	
O5	Motor Torque			%		4	
O6	Motor Power			%		5	
O7	Motor Voltage			V		6	
O8	DC-link Voltage			V		7	
O9	Unit Temperature			°C		8	
O10	Motor Temperature			%		9	
R11 ②	Keypad Reference	See Par ID 101	See Par ID 102	Hz	0.00	141	
R12 ②	PID1 Keypad Set Point 1	See Par ID 1298	See Par ID 1300	Varies	0.00	1307	
R13 ②	PID1 Keypad Set Point 2	See Par ID 1298	See Par ID 1300	Varies	0.00	1309	

- Note:**
- ① Parameter value can only be changed after the drive has stopped.
 - ② Parameter value will be set to be default when changing macros.
 - ③ Input function is level sensed.
 - ④ Input function is edge sensed.
 - ⑤ Input function is edge sensed when using StartP/StopP start logic.

Appendix A—Description of parameters

On the following pages you will find the parameter descriptions arranged according to the parameter number.

Some parameter names are followed by a number code indicating the applications in which the parameter is included. See the list of applications below. The parameter numbers under which the parameter appears in different applications are also given.

Application level

- 1 Basic
- 2 PID
- 3 Advanced

Code	Modbus ID	Parameter	Application	RO/RW
P1.1	101	Min Frequency Sets the lower limit for the frequency of the motor. This will limit other frequency parameter settings; Preset Speeds, Jog Speed, 4mA Fault preset speed, Fire Mode speed, and brake speed settings.	1,2,3	RW
P1.2	102	Max Frequency Sets the upper limit for the frequency of the motor. This will limit other frequency parameter settings; Preset Speeds, Jog Speed, 4mA Fault preset speed, Fire Mode speed, and brake speed settings.	1,2,3	RW
P1.3	103	Accel Time 1 Use this parameter to set the acceleration ramp time 1 in seconds.	1,2,3	RW
P1.4	104	Decel Time 1 Use this parameter to set the deceleration ramp time 1 in seconds.	1,2,3	RW

Figure 28. Acceleration and deceleration time

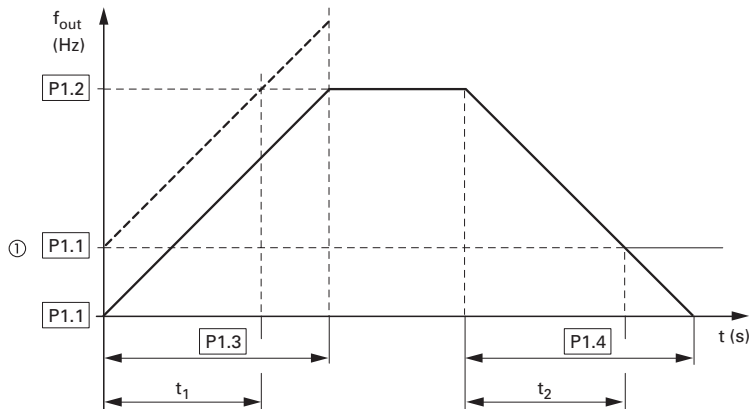

The values for the acceleration time t_1 and the deceleration time t_2 are calculated as follows:

$$t_1 = \frac{(P1.2 - P1.1) \times P1.3}{P1.2} \quad t_2 = \frac{(P1.2 - P1.1) \times P1.4}{P1.2}$$

The defined acceleration (ID103) and deceleration times ID104 apply for all changes to the frequency setpoint value.

If the start-release (FWD, REV) is switched off, the output frequency (f_{out}) is immediately set to zero. The motor runs down uncontrolled.

If a controlled run-down is requested (with value from ID104), stop mode should be set to ramp.

① When setting a minimum output frequency (ID104 greater than 0 Hz), the acceleration and deceleration time of the drive is reduced to t_1 or t_2 .

Code	Modbus ID	Parameter	Application	RO/RW
P1.5		Motor Nom Current	1,2,3	RW

Use this parameter to set the Motor rated current.

Figure 29. Motor parameters from ratings plate

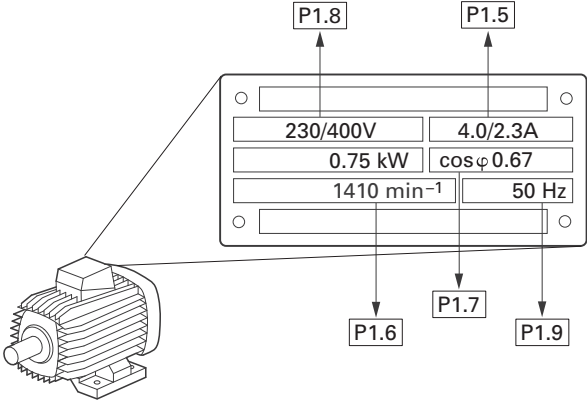

P1.6	489	Motor Nom Speed	1,2,3	RW
Use this parameter to set the Motor Rated Speed.				
P1.7	490	Motor PF	1,2,3	RW
Use this parameter to set the Power factor cos phi of the motor.				
P1.8	487	Motor Nom Voltage	1,2,3	RW
Use this parameter to set the motor rated voltage.				
P1.9	488	Motor Nom Frequency	1,2,3	RW
The rated frequency of the motor. This is the frequency at which "Motor Nom Voltage" is applied to the motor. Below this frequency, the applied motor voltage will be reduced. Above this frequency the voltage remains limited to "Motor Nom Voltage"				
P1.10	2465	HOA Source	1,2,3	RW
Use this parameter to enables the HOA control function. If enabled it selects the desired location for switching between Hand, Off, and Auto control locations.				
0 - I/O terminal/Keypad/Fieldbus - Controlled by either control terminals, keypad or fieldbus location.				
1 - Keypad - Drive is looking for control source location from the keypad Hand/OFF/AUTO buttons only.				
2 -I/O Terminal - Drive is looking at the control terminals only for the control place selection.				
3 - Fieldbus - Drive is looking at the Feildbus control selection only for the control place selection.				
P1.11	1695	Hand Control Place	1,2,3	RW
Selects where the drive will look for the start command in the "Hand" location.				
<ul style="list-style-type: none"> • I/O terminal Start 1 and 2 would be from the Digital hardwired inputs assigned via the input group • Fieldbus would be from a communication bus. • Keypad would be from the Start/Stop buttons on the keypad. 				

Appendix A—Description of parameters

Code	Modbus ID	Parameter	Application	RO/RW
P1.12	136	<p>Hand Reference</p> <p>This parameter determines the reference for "Hand" control mode.</p> <p>0 = AI1 - Control Terminals 2 and 3, defined as a voltage or current signal input based on S1 DIP switch setting. Parameter settings done in Analog input group.</p> <p>1 = AI2 - Control Terminals 4 and 5, defined as a current or voltage signal input based on S2 and S3 DIP switch setting. Parameter settings done in Analog input group.</p> <p>2 = Slot A: AI1 - Comes from the slot A DXG-EXT-1AI2AO board, defined as a voltage or current signal based off on board DIP switch. See Option card Manual for more details.</p> <p>3 = Slot B: AI1 - Comes from the slot B DXG-EXT-1AI2AO board, defined as a voltage or current signal based off on board DIP switch. See Option card Manual for more details.</p> <p>4 = AI1 Joystick - Control Terminals 2 and 3, defined as a voltage or current signal input based on S1 DIP switch setting. Parameter settings done in Analog input group.</p> <p>5 = AI2 Joystick - Control Terminals 4 and 5, defined as a current or voltage signal input based on S2 and S3 DIP switch setting. Parameter settings done in Analog input group.</p> <p>6 = Keypad - Keypad Up and down buttons change keypad reference parameter Para ID 141.</p> <p>7 = Fieldbus Ref - Speed reference word used to define speed. Check Communication Manual for more details.</p> <p>9 = Max Frequency - Run at the Para ID 102 Max Frequency level.</p> <p>10 = AI1 + AI2 - Sum of the AI1 and AI2 signals. See Option 0 and 1 for input details.</p> <p>11 = AI1 - AI2 - AI1 signal value minus AI2 signal value. See Option 0 and 1 for input details.</p> <p>12 = AI2 - AI1 - AI2 signal value minus AI1 signal value. See Option 0 and 1 for input details.</p> <p>13 = AI1 * AI2 - AI1 signal value multiplied by AI2 signal value. See Option 0 and 1 for input details.</p> <p>14 = AI1 or AI2 - AI1 signal value or AI2 signal value. See Digital input group to assign select input signal. See Option 0 and 1 for input details.</p> <p>15 = Min(AI1,AI2) - Minimum of AI1 signal value or AI2 signal value. See Option 0 and 1 for input details.</p> <p>16 = Max(AI1,AI2) - Maximum of AI1 signal value or AI2 signal value. See Option 0 and 1 for input details.</p> <p>17 = PID1 Control Output - PID controller 1 output , see PID group for setup.</p> <p>18 = PID2 Control Output - PID controller 2 output. see PID group for setup.</p>	1,2,3	RW
P1.13	135	<p>Auto 1 Control Place</p> <p>Selects where the drive will look for the start command in the "Auto 1" location.</p> <ul style="list-style-type: none"> • I/O terminal Start 1 and 2 would be from the Digital hardwired inputs assigned via the input group • Fieldbus would be from a communication bus. • Keypad would be from the Start/Stop buttons on the keypad. 	1,2,3	RW
P1.14	137	<p>Auto 1 Reference</p> <p>This parameter determines the reference for "Auto 1" control mode.</p> <p>0 = AI1 - Control Terminals 2 and 3, defined as a voltage or current signal input based on S1 DIP switch setting. Parameter settings done in Analog input group.</p> <p>1 = AI2 - Control Terminals 4 and 5, defined as a current or voltage signal input based on S2 and S3 DIP switch setting. Parameter settings done in Analog input group.</p> <p>2 = Slot A: AI1 - Comes from the slot A DXG-EXT-1AI2AO board, defined as a voltage or current signal based off on board DIP switch. See Option card Manual for more details.</p> <p>3 = Slot B: AI1 - Comes from the slot B DXG-EXT-1AI2AO board, defined as a voltage or current signal based off on board DIP switch. See Option card Manual for more details.</p> <p>4 = AI1 Joystick - Control Terminals 2 and 3, defined as a voltage or current signal input based on S1 DIP switch setting. Parameter settings done in Analog input group.</p> <p>5 = AI2 Joystick - Control Terminals 4 and 5, defined as a current or voltage signal input based on S2 and S3 DIP switch setting. Parameter settings done in Analog input group.</p> <p>6 = Keypad - Keypad Up and down buttons change keypad reference parameter Para ID 141.</p> <p>7 = Fieldbus Ref - Speed reference word used to define speed. Check Communication Manual for more details.</p> <p>9 = Max Frequency - Run at the Para ID 102 Max Frequency level.</p> <p>10 = AI1 + AI2 - Sum of the AI1 and AI2 signals. See Option 0 and 1 for input details.</p> <p>11 = AI1 - AI2 - AI1 signal value minus AI2 signal value. See Option 0 and 1 for input details.</p> <p>12 = AI2 - AI1 - AI2 signal value minus AI1 signal value. See Option 0 and 1 for input details.</p> <p>13 = AI1 * AI2 - AI1 signal value multiplied by AI2 signal value. See Option 0 and 1 for input details.</p> <p>14 = AI1 or AI2 - AI1 signal value or AI2 signal value. See Digital input group to assign select input signal. See Option 0 and 1 for input details.</p> <p>15 = Min(AI1,AI2) - Minimum of AI1 signal value or AI2 signal value. See Option 0 and 1 for input details.</p> <p>16 = Max(AI1,AI2) - Maximum of AI1 signal value or AI2 signal value. See Option 0 and 1 for input details.</p> <p>17 = PID1 Control Output - PID controller 1 output , see PID group for setup.</p> <p>18 = PID2 Control Output - PID controller 2 output. see PID group for setup.</p>	1,2,3	RW
P1.15	138	<p>Auto 2 Control Place</p> <p>Selects where the drive will look for the start command in the "Auto 2" location. Using the Remote 1/2 select digital input will select between control place 1 and 2.</p> <ul style="list-style-type: none"> • I/O terminal Start 1 and 2 would be from the Digital hardwired inputs assigned via the input group • Fieldbus would be from a communication bus. • Keypad would be from the Start/Stop buttons on the keypad. 	1,2,3	RW

Code	Modbus ID	Parameter	Application	RO/RW
P1.16	139	<p>Auto 2 Reference</p> <p>Use this parameter to select what frequency reference source to look at when in the “Auto 2” control mode.</p> <p>0 = AI1 - Control Terminals 2 and 3, defined as a voltage or current signal input based on S1 DIP switch setting. Parameter settings done in Analog input group.</p> <p>1 = AI2 - Control Terminals 4 and 5, defined as a current or voltage signal input based on S2 and S3 DIP switch setting. Parameter settings done in Analog input group.</p> <p>2 = Slot A: AI1 - Comes from the slot A DXG-EXT-1AI2AO board, defined as a voltage or current signal based off on board DIP switch. See Option card Manual for more details.</p> <p>3 = Slot B: AI1 - Comes from the slot B DXG-EXT-1AI2AO board, defined as a voltage or current signal based off on board DIP switch. See Option card Manual for more details.</p> <p>4 = AI1 Joystick - Control Terminals 2 and 3, defined as a voltage or current signal input based on S1 DIP switch setting. Parameter settings done in Analog input group.</p> <p>5 = AI2 Joystick - Control Terminals 4 and 5, defined as a current or voltage signal input based on S2 and S3 DIP switch setting. Parameter settings done in Analog input group.</p> <p>6 = Keypad - Keypad Up and down buttons change keypad reference parameter Para ID 141.</p> <p>7 = Fieldbus Ref - Speed reference word used to define speed. Check Communication Manual for more details.</p> <p>9 = Max Frequency - Run at the Para ID 102 Max Frequency level.</p> <p>10 = AI1 + AI2 - Sum of the AI1 and AI2 signals. See Option 0 and 1 for input details.</p> <p>11 = AI1 - AI2 - AI1 signal value minus AI2 signal value. See Option 0 and 1 for input details.</p> <p>12 = AI2 - AI1 - AI2 signal value minus AI1 signal value. See Option 0 and 1 for input details.</p> <p>13 = AI1 * AI2 - AI1 signal value multiplied by AI2 signal value. See Option 0 and 1 for input details.</p> <p>14 = AI1 or AI2 - AI1 signal value or AI2 signal value. See Digital input group to assign select input signal. See Option 0 and 1 for input details.</p> <p>15 = Min(AI1,AI2) - Minimum of AI1 signal value or AI2 signal value. See Option 0 and 1 for input details.</p> <p>16 = Max(AI1,AI2) - Maximum of AI1 signal value or AI2 signal value. See Option 0 and 1 for input details.</p> <p>17 = PID1 Control Output - PID controller 1 output , see PID group for setup.</p> <p>18 = PID2 Control Output - PID controller 2 output. see PID group for setup.</p>	1,2,3	RW
P2.1.1	483	<p>Damper Start</p> <p>Use this parameter to set the start mode condition to include an external damper circuit.</p> <p>0 = Start—standard start</p> <p>1 = Interlocked Start—To use this, a relay output, R01–R03, needs to be programmed for selections 35 “Damper Control,” and a digital input DIN must be programmed for selection “RunEn/INTLK.” The relay output is used to energize an element of the driven system, such as a damper, seal water solenoid, or a pre-lube pump. Upon a return acknowledgement contact closure to the programmed digital input, the frequency converter will start.</p> <p>2 = Interlock Time Start—This functions the same as the Interlocked Start, except that if the return acknowledgement contact is not received within the Interlock Timeout, a “prevent-up start” fault is displayed in keypad and the start sequence will need to be restarted.</p> <p>3 = Delay Start—This start is similar to the Interlocked Start, except that a return contact is not used. After the “Delay Time” following the relay output closure, the frequency converter starts.</p>	2,3	RW
P2.1.2	484	<p>Damper Time Out</p> <p>Use this parameter to set the timeout time used for an Interlocked Time Start, if the time is expired before getting a feedback, the start sequence must be restarted if no acknowledgment contact is received.</p>	2,3	RW
P2.1.3	485	<p>Damper Delay</p> <p>Use this parameter to set the delay time following a the Delay Start start mode selection, once the time has expired the drive will being to ramp the output.</p>	2,3	RW
P2.1.4	144	<p>AI Ref Scale Min Value</p> <p>Min Frequency when min of Analog References is applied. With values set at 0 scaling will follow the minimum frequency value parameter Para ID 101.</p>	1,2,3	RW

Appendix A—Description of parameters

Code	Modbus ID	Parameter	Application	RO/RW
P2.1.5	145	AI Ref Scale Max Value	1,2,3	RW

Max Frequency when max of Analog Reference is applied. With values set at 0 scaling will follow the maximum frequency value parameter Para ID 102.

Figure 30. With and without reference scaling

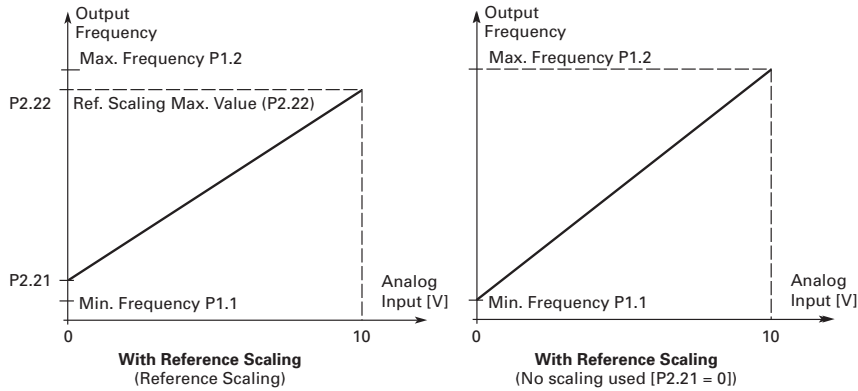

P2.2.1	143	I0 Terminal 1 Start Stop Logic	1,2,3	RW
--------	-----	---------------------------------------	-------	----

This parameter defines the start and stop of the drive with the digital signals.

0 = Para ID 190: DI closed contact = start forward Para ID 191: DI closed contact = start reverse - This would be considered 2 wire control with either a contact used on the Start FWD or Start REV commands. Contacts Open the motor stops.

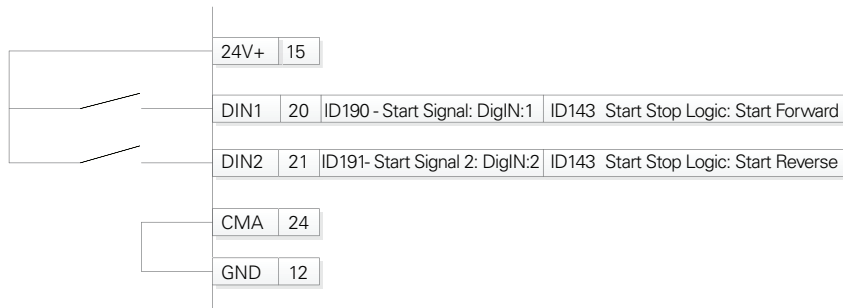
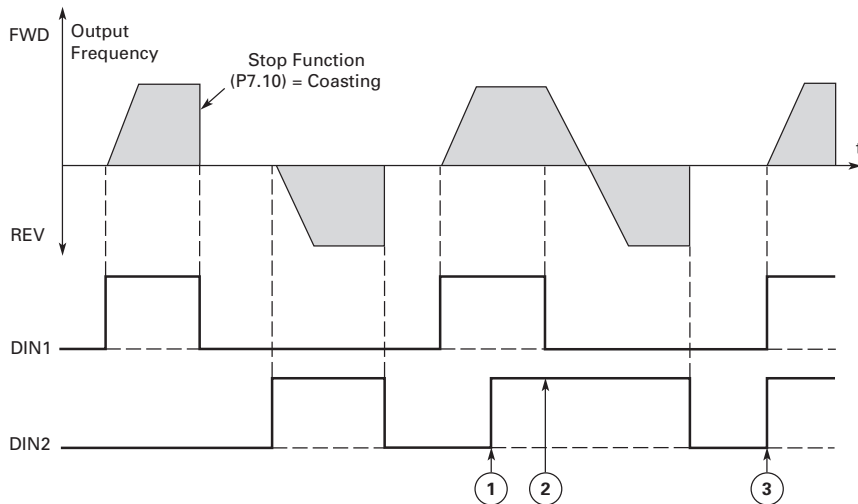

Figure 31. Start forward/start reverse



Code	Modbus ID	Parameter	Application	RO/RW
P2.2.1	143	1 = Para ID 190: DI closed contact = start / open contact = stop Para ID 191: DI closed contact = reverse / open contact = forward - This would be considered 2 wire control with a contact on start/stop, contact open it stops and direction on 2nd start signal.	1,2,3	RW

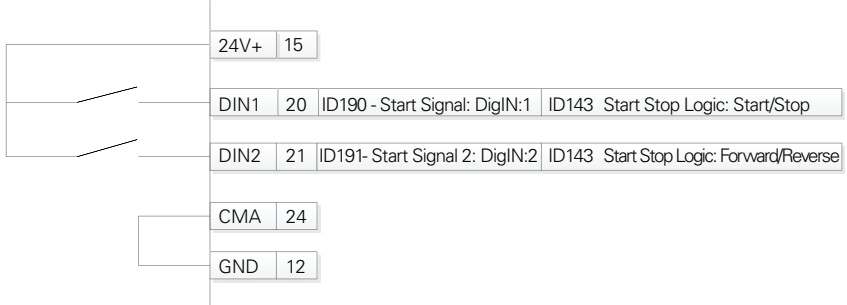
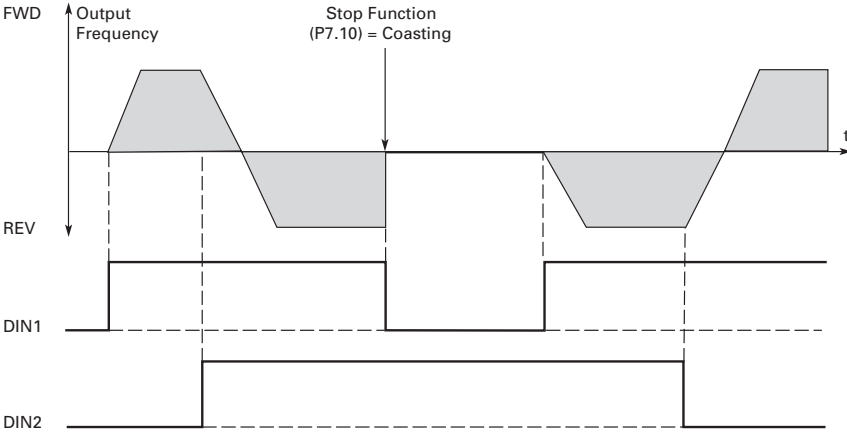
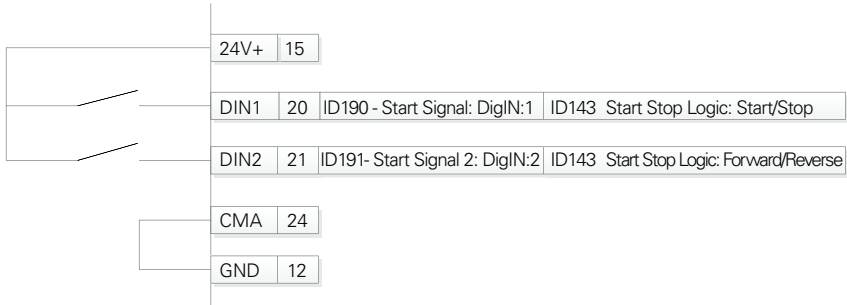

Figure 32. Start, stop and reverse



- Notes:**
- ▣ The first selected direction has the highest priority.
 - ▣ When the DIN1 contact opens the direction of rotation starts to change.
 - ▣ If Start forward (DIN1) and Start reverse (DIN2) signals are active simultaneously the Start forward signal (DIN1) has priority.

2 = Para ID 190: DI closed contact = start / open contact = stop Para ID 191: DI closed contact = start enabled / open contact = start disabled and drive stopped if running Motor direction keeps forward - This would be considered 3 wire control with Start signal 2 required to be closed to enable Start on Start signal 1.



Appendix A—Description of parameters

Code	Modbus ID	Parameter	Application	RO/RW
P2.2.1	143	3 = Three-wire connection (pulse control): Para ID 190: DI changes from open to closed = start pulse Para ID 191: DI changes from closed to open = stop pulse Para ID 198: DI closed contact = reverse/ open contact = forward - This would be considered 3 wire control with Start Signal 1 being the Start Pulse and Start Signal 2 being the NC Stop.	1,2,3	RW

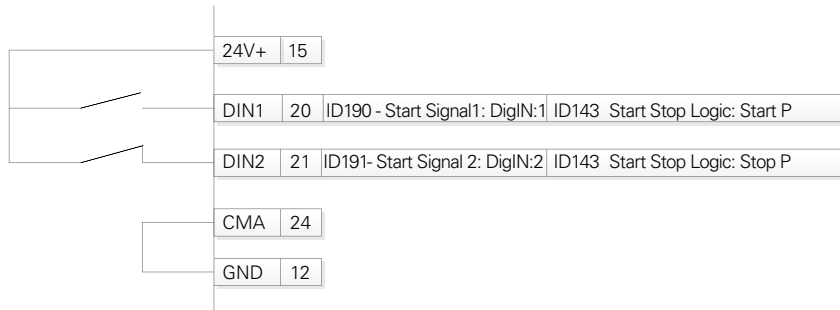
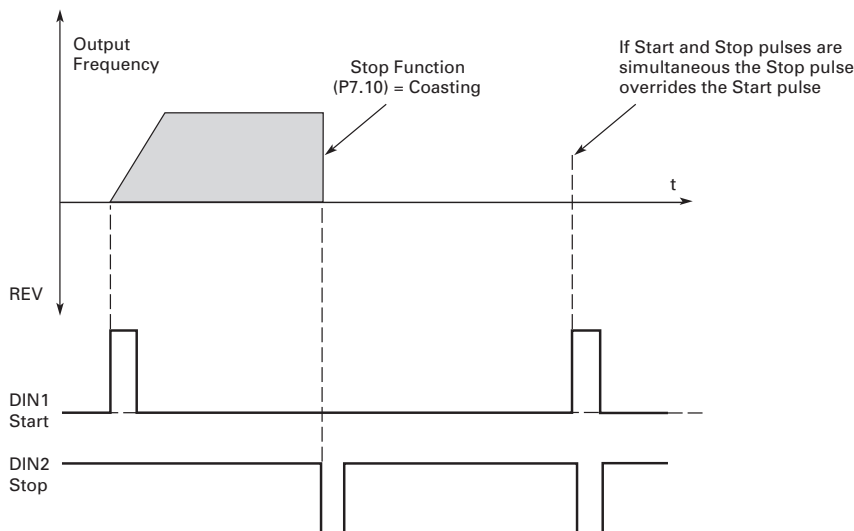

Figure 33. Start pulse/stop pulse



P2.2.2	190	IO Terminal 1 Start Signal 1 Signal selection 1 for the start/stop logic listed in parameter Para ID 143. This parameter would correspond to the function listed for DIN1. When the parameter is set to DigIN: 1 it references DIN1 on the control board, selecting different DIGIN values will assign it to a different input on the control board or option card. When set to Normally Open this function would be always tied low or 0 when using I/O terminal 1 as the control place. When value is set to Normally Closed this will cause the function to be always on and activate the output if I/O Terminal 1 is the current control place. Can be set to DigilN:X indicates on board terminal inputs, DigilN:A:IOX:X indicates optional board inputs in A slot, DigilN:B:IOX:X indicates optional board inputs in B slot, or Timer Channel X	1,2,3	RW
P2.2.3	191	IO Terminal 1 Start Signal 2 Signal selection 2 for the start/stop logic listed in parameter Para ID 143. This parameter would correspond to the function listed for DIN2. When the parameter is set to DigIN: 2 it references DIN2 on the control board, selecting different DIGIN values will assign it to a different input on the control board or option card. When set to Normally Open this function would be always tied low or 0 when using I/O terminal 1 as the control place. When value is set to Normally Closed this will cause the function to be always on and activate the output if I/O Terminal 1 is the current control place. Can be set to DigilN:X indicates on board terminal inputs, DigilN:A:IOX:X indicates optional board inputs in A slot, DigilN:B:IOX:X indicates optional board inputs in B slot, or Timer Channel X	1,2,3	RW

Code	Modbus ID	Parameter	Application	RO/RW
P2.2.4	2206	IO Terminal 2 Start Stop Logic	1,2,3	RW

This parameter defines the start and stop of the drive with the digital signals.
 0 = Para ID 2207: DI closed contact = start forward Para ID 2208: DI closed contact = start reverse -
 This would be considered 2 wire control with either a contact used on the Start FWD or Start REV commands. Contacts Open the motor stops.

Figure 34. Start forward/start reverse

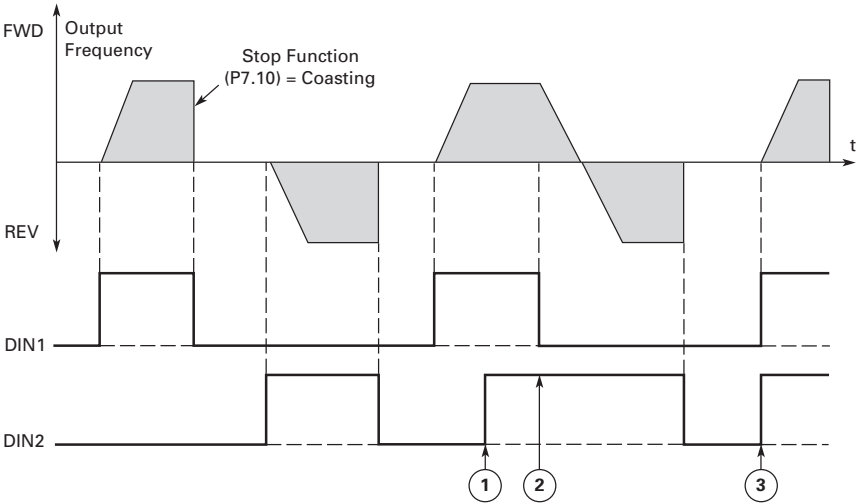

1 = Para ID 2207: DI closed contact = start /open contact = stop Para ID 2208: DI closed contact = reverse / open contact = forward - This would be considered 2 wire control with a contact on start/stop, contact open it stops and direction on 2nd start signal.

Figure 53. Start, stop and reverse

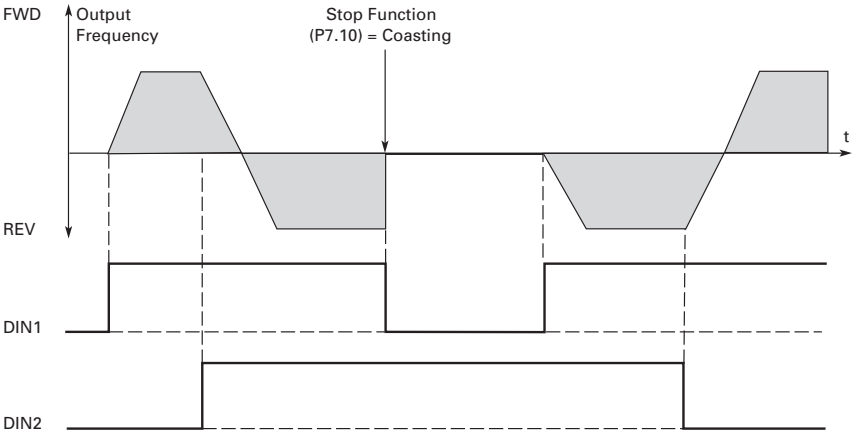

- Notes:
- ① The first selected direction has the highest priority.
 - ② When the DIN1 contact opens the direction of rotation starts to change.
 - ③ If Start forward (DIN1) and Start reverse (DIN2) signals are active simultaneously the Start forward signal (DIN1) has priority.

Appendix A—Description of parameters

Code	Modbus ID	Parameter	Application	RO/RW
P2.2.4	2206	<p>2 = Para ID 2207: DI closed contact = start / open contact = stop Para ID 2208: DI closed contact = start enabled / open contact = start disabled and drive stopped if running Motor direction keeps forward - This would be considered 3 wire control with Start signal 2 required to be closed to enable Start on Start signal 1.</p> <p>3 = Three-wire connection (pulse control): Para ID 2207: DI changes from open to closed = start pulse Para ID 2208: DI changes from closed to open = stop pulse Para ID 198: DI closed contact = reverse / open contact = forward - This would be considered 3 wire control with Start Signal 1 being the Start Pulse and Start Signal 2 being the NC Stop.</p>	1,2,3	RW

Figure 35. Start pulse/stop pulse

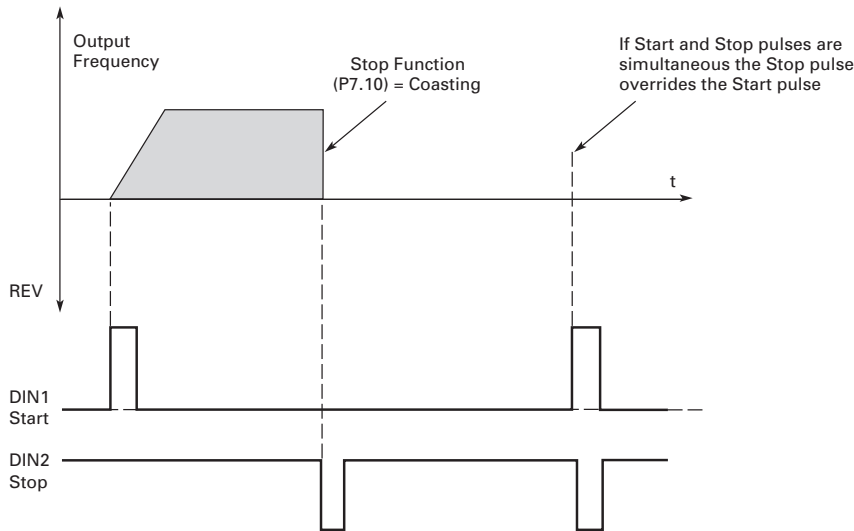

P2.2.5	2207	<p>IO Terminal 2 Start Signal 1</p> <p>The 2nd Signal selection 1 for the start/stop logic listed in parameter Para ID 2206. When the parameter is set to DigiN: 1 it references DIN1 on the control board, selecting different DigiN values will assign it to a different input on the control board or option card. When set to Normally Open this function would be always tied low or 0 when using I/O terminal 1 as the control place. When value is set to Normally Closed this will cause the function to be always on and activate the output if I/O Terminal 1 is the current control place. Can be set to DigiN:X indicates on board terminal inputs, DigiN:A:IOX:X indicates optional board inputs in A slot, DigiN:B:IOX:X indicates optional board inputs in B slot, or Timer Channel X</p>	1,2,3	RW
P2.2.6	2208	<p>IO Terminal 2 Start Signal 2</p> <p>The 2nd Signal selection 2 for the start/stop logic listed in parameter Para ID 2206. When the parameter is set to DigiN: 2 it references DIN2 on the control board, selecting different DigiN values will assign it to a different input on the control board or option card. When set to Normally Open this function would be always tied low or 0 when using I/O terminal 1 as the control place. When value is set to Normally Closed this will cause the function to be always on and activate the output if I/O Terminal 1 is the current control place. Can be set to DigiN:X indicates on board terminal inputs, DigiN:A:IOX:X indicates optional board inputs in A slot, DigiN:B:IOX:X indicates optional board inputs in B slot, or Timer Channel X</p>	1,2,3	RW
P2.2.7	881	<p>Thermistor Input Select</p> <p>This parameter defines DIN7, and DIN8 is digital input or thermistor input. When this parameter is enabled it switches DIN7 and DIN8 to a thermistor input that triggers at 4.7k ohm.</p>	1,2,3	RW
P2.2.8	198	<p>Reverse</p> <p>Use this parameter for switching the direction of the motor to reverse when using 3 wire start/stop logic parameter in Para ID 143 = 3. Can be set to DigiN:X indicates on board terminal inputs, DigiN:A:IOX:X indicates optional board inputs in A slot, DigiN:B:IOX:X indicates optional board inputs in B slot, or Timer Channel X Contact Open = Forward direction. Contact Close = Reverse direction.</p>	1,2,3	RW

Code	Modbus ID	Parameter	Application	RO/RW
P2.2.9	192	Ext. Fault 1 NO Use this parameter for setting external input causing drive to fault. This function is defined as NO so the function activates on a closed contact. If this function is assigned to Normally Open - the function is always off so the drive will not fault, when set to Normally Closed the function will be active and fault all the time. The additional settings allow assigning them to an input to control the function. Different Settings DigiIN:X indicates on board terminal inputs, DigiIN:A:IOX:X indicates optional board inputs in A slot, DigiIN:B:IOX:X indicates optional board inputs in B slot, or Timer Channel X. The description on the fault can be changed in parameter Para ID 2297. RO X Function allows for having an input turn on without having to hard wire it to the physical relay output. Closed contact = external fault. Open contact = no external fault.	1,2,3	RW
P2.2.10	193	Ext. Fault 1 NC Use this parameter for setting external input causing drive to fault. This function is defined as NC so the function activates on a open contact. If this function is assigned to Normally Closed - the function is always on so the drive will not fault, when set to Normally Open the function will be active and fault all the time. The additional settings allow assigning them to an input to control the function. Different Settings DigiIN:X indicates on board terminal inputs, DigiIN:A:IOX:X indicates optional board inputs in A slot, DigiIN:B:IOX:X indicates optional board inputs in B slot, or Timer Channel X. The description on the fault can be changed in parameter Para ID 2297. RO X Function allows for having an input turn on without having to hard wire it to the physical relay output. Closed contact = no external fault. Open contact = external fault.	1,2,3	RW
P2.2.11	2297	Ext. Fault 1 Text This parameter allows for the text to be changed when using external Fault 1 NO or NC. 0 = External Fault 1 = Vibration Cut Out 2 = High Motor Temp 3 = Low Pressure 4 = High Pressure 5 = Low Water 6 = Damper Interlock 7 = Run Enable 8 = Freeze Stat Trip 9 = Smoke Detect 10 = Seal Leakage 11 = Rod Breakage	1,2,3	RW
P2.2.12	2293	Ext. Fault 2 NO Use this parameter for setting external input causing drive to fault. This function is defined as NO so the function activates on a closed contact. If this function is assigned to Normally Open - the function is always off so the drive will not fault, when set to Normally Closed the function will be active and fault all the time. The additional settings allow assigning them to an input to control the function. Can be set to DigiIN:X indicates on board terminal inputs, DigiIN:A:IOX:X indicates optional board inputs in A slot, DigiIN:B:IOX:X indicates optional board inputs in B slot, or Timer Channel X. RO X Function allows for having an input turn on without having to hard wire it to the physical relay output. The description on the fault can be changed in parameter Para ID 2298. Closed contact = external fault. Open contact = no external fault.	1,2,3	RW
P2.2.13	2294	Ext. Fault 2 NC Use this parameter for setting external input causing drive to fault. This function is defined as NC so the function activates on a open contact. If this function is assigned to Normally Closed - the function is always on so the drive will not fault, when set to Normally Open the function will be active and fault all the time. The additional settings allow assigning them to an input to control the function. Can be set to DigiIN:X indicates on board terminal inputs, DigiIN:A:IOX:X indicates optional board inputs in A slot, DigiIN:B:IOX:X indicates optional board inputs in B slot, or Timer Channel X. RO X Function allows for having an input turn on without having to hard wire it to the physical relay output. The description on the fault can be changed in parameter Para ID 2298. Closed contact = no external fault. Open contact = external fault.	1,2,3	RW

Appendix A—Description of parameters

Code	Modbus ID	Parameter	Application	RO/RW
P2.2.14	2298	Ext. Fault 2 Text This parameter allows for the text to be changed when using external Fault 1 NO or NC. 0 = External Fault 1 = Vibration Cut Out 2 = High Motor Temp 3 = Low Pressure 4 = High Pressure 5 = Low Water 6 = Damper Interlock 7 = Run Enable 8 = Freeze Stat Trip 9 = Smoke Detect 10 = Seal Leakage 11 = Rod Breakage	1,2,3	RW
P2.2.15	2295	Ext. Fault 3 NO Use this parameter for setting external input causing drive to fault. This function is defined as NO so the function activates on a closed contact. If this function is assigned to Normally Open - the function is always off so the drive will not fault, when set to Normally Closed the function will be active and fault all the time. The additional settings allow assigning them to an input to control the function. Can be set to DigilN:X indicates on board terminal inputs, DigilN:A:IOX:X indicates optional board inputs in A slot, DigilN:B:IOX:X indicates optional board inputs in B slot, or Timer Channel X. RO X Function allows for having an input turn on without having to hard wire it to the physical relay output. The description on the fault can be changed in parameter Para ID 2299. Closed contact = external fault. Open contact = no external fault.	1,2,3	RW
P2.2.16	2296	Ext. Fault 3 NC Use this parameter for setting external input causing drive to fault. This function is defined as NC so the function activates on an open contact. If this function is assigned to Normally Closed - the function is always on so the drive will not fault, when set to Normally Open the function will be active and fault all the time. The additional settings allow assigning them to an input to control the function. Can be set to DigilN:X indicates on board terminal inputs, DigilN:A:IOX:X indicates optional board inputs in A slot, DigilN:B:IOX:X indicates optional board inputs in B slot, or Timer Channel X. RO X Function allows for having an input turn on without having to hard wire it to the physical relay output. The description on the fault can be changed in parameter Para ID 2299. Closed contact = no external fault. Open contact = external fault.	1,2,3	RW
P2.2.17	2299	Ext. Fault 3 Text This parameter allows for the text to be changed when using external Fault 1 NO or NC. 0 = External Fault 1 = Vibration Cut Out 2 = High Motor Temp 3 = Low Pressure 4 = High Pressure 5 = Low Water 6 = Damper Interlock 7 = Run Enable 8 = Freeze Stat Trip 9 = Smoke Detect 10 = Seal Leakage 11 = Rod Breakage	1,2,3	RW
P2.2.18	200	Fault Reset Use this parameter for setting external fault reset input. This function is looking for a rising edge to reset a fault. If this function is set for Normally Open, the drive will not do a reset via the control terminals. When set for Normally Closed, the fault condition will always be trying to reset on the rising edge. When it is tied to an input on the control board or option card the function would be set to DIGIN: and the input desired. Can be set to DigilN:X indicates on board terminal inputs, DigilN:A:IOX:X indicates optional board inputs in A slot, DigilN:B:IOX:X indicates optional board inputs in B slot, or Timer Channel X. RO X Function allows for having an input turn on without having to hard wire it to the physical relay output. DI change from open contact to closed contact: reset fault.	1,2,3	RW

Code	Modbus ID	Parameter	Application	RO/RW
P2.2.19	194	Run Enable Use this parameter for setting external safety start input that is required along with start command for frequency converter to turn on output. When using this command if the function is set for Normally Open, the drive will see this as a open input and not allow the drive to run due to no Ready. The default state being Normally Closed indicates that the drive is in a Ready condition and will accept the start command. When assigned to one of the DIGIN or Time channels it requires the input to be high to activate output. Can be set to DigiIN:X indicates on board terminal inputs, DigiIN:A:IOX:X indicates optional board inputs in A slot, DigiIN:B:IOX:X indicates optional board inputs in B slot, or Timer Channel X. RO X Function allows for having an input turn on without having to hard wire it to the physical relay output. Closed contact = Start of motor enabled Open contact = Start of motor disabled	1,2,3	RW
P2.2.20	205	Preset Speed B0 Use this parameter selecting the of the digital input for an external speed setpoint desired. Validating 3 digital inputs will allow for 7 preset speeds to be obtained. When switching between inputs it will follow the acceleration and deceleration time. When all the inputs are set to Normally Open none of the preset speeds will be enabled and the output will follow the control place reference command. If the function is set for Normally Closed the drive will follow the preset speed assigned to the inputs enabled. When assigned to one of the DIGIN on the control board or an installed option card it is looking for a high input to enable that preset. Can be set to DigiIN:X indicates on board terminal inputs, DigiIN:A:IOX:X indicates optional board inputs in A slot, DigiIN:B:IOX:X indicates optional board inputs in B slot, or Timer Channel X. RO X Function allows for having an input turn on without having to hard wire it to the physical relay output.	1,2,3	RW
P2.2.21	206	Preset Speed B1 Use this parameter selecting the of the digital input for an external speed setpoint desired. Validating 3 digital inputs will allow for 7 preset speeds to be obtained. When switching between inputs it will follow the acceleration and deceleration time. When all the inputs are set to Normally Open none of the preset speeds will be enabled and the output will follow the control place reference command. If the function is set for Normally Closed the drive will follow the preset speed assigned to the inputs enabled. When assigned to one of the DIGIN on the control board or an installed option card it is looking for a high input to enable that preset. Can be set to DigiIN:X indicates on board terminal inputs, DigiIN:A:IOX:X indicates optional board inputs in A slot, DigiIN:B:IOX:X indicates optional board inputs in B slot, or Timer Channel X. RO X Function allows for having an input turn on without having to hard wire it to the physical relay output.	1,2,3	RW

Appendix A—Description of parameters

Code	Modbus ID	Parameter	Application	RO/RW
P2.2.22	207	Preset Speed B2	1,2,3	RW

Use this parameter selecting the of the digital input for an external speed setpoint desired. Validating 3 digital inputs will allow for 7 preset speeds to be obtained. When switching between inputs it will follow the acceleration and deceleration time. When all the inputs are set to Normally Open none of the preset speeds will be enabled and the output will follow the control place reference command. If the function is set for Normally Closed the drive will follow the preset speed assigned to the inputs enabled. When assigned to one of the DIGIN on the control board or an installed option card it is looking for a high input to enable that preset. Can be set to DigiIN:X indicates on board terminal inputs, DigiIN:A:IOX:X indicates optional board inputs in A slot, DigiIN:B:IOX:X indicates optional board inputs in B slot, or Timer Channel X. RO X Function allows for having an input turn on without having to hard wire it to the physical relay output.

Figure 36. Activation of fixed frequencies

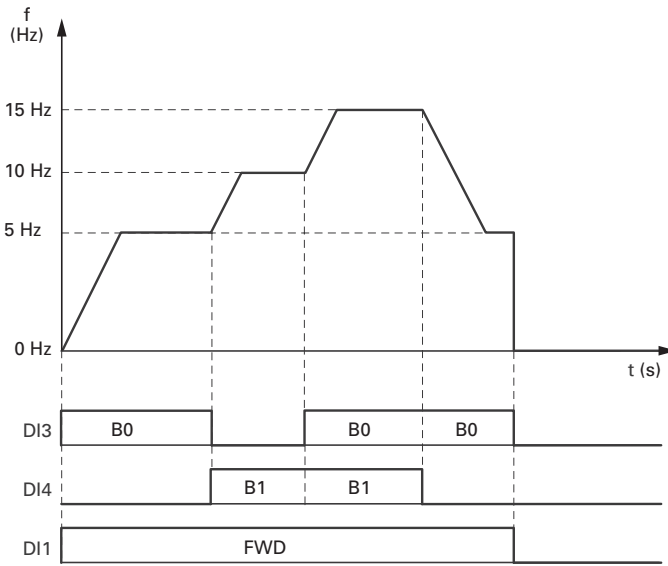

P2.2.23	199	Jog Enable	1,2,3	RW
---------	-----	-------------------	-------	----

Use this parameter for selecting an external input for enabling the jog frequency reference and starts the drive to slowly advance the system. When this function is set for Normally Open the drive will not follow the jog enable speed. If the function is set for Normally Close then the output will be activated and run at the Jog Frequency. Can be set to DigiIN:X indicates on board terminal inputs, DigiIN:A:IOX:X indicates optional board inputs in A slot, DigiIN:B:IOX:X indicates optional board inputs in B slot, or Timer Channel X. RO X Function allows for having an input turn on without having to hard wire it to the physical relay output.
Closed contact: drive is under jog mode.

P2.2.24	195	Accel/Decel Time Set	1,2,3	RW
---------	-----	-----------------------------	-------	----

Use this parameter for selecting the external digital input used to select between accel/decel time 1 and accel/decel time 2. When this function is set for Normally Open the Accel/Decel time set will follow time 1 always, when set for Normally Closed it will follow the 2nd Accel/Decel time always. Assigning it to an input will allow for the input to control this. Can be set to DigiIN:X indicates on board terminal inputs, DigiIN:A:IOX:X indicates optional board inputs in A slot, DigiIN:B:IOX:X indicates optional board inputs in B slot, or Timer Channel X. RO X Function allows for having an input turn on without having to hard wire it to the physical relay output.
Closed contact = 2nd set of acc/dec time applied.
Open contact = 1st set of acc/dec time applied.

P2.2.25	201	Accel/Decel Prohibit	1,2,3	RW
---------	-----	-----------------------------	-------	----

Use this parameter for selecting an external input used to disables the ability to change speed, even if the reference signal changes if this input is enabled the output stays at the value it was at before the input was enabled. When this functions is set for Normally Open the Accel/Decel will be allowed via the desired control source, when is set for Normally Closed the drive will prohibit changing of speed from any control source. Can be set to DigiIN:X indicates on board terminal inputs, DigiIN:A:IOX:X indicates optional board inputs in A slot, DigiIN:B:IOX:X indicates optional board inputs in B slot, or Timer Channel X. RO X Function allows for having an input turn on without having to hard wire it to the physical relay output.
Closed contact: drive output frequency cannot rise or fall, it keeps on current output.

Code	Modbus ID	Parameter	Application	RO/RW
P2.2.26	215	No Access To Param Use this parameter selecting an external input for locking out the ability to change parameters when this input is enabled, this can be used with the password protection. When this function is set for Normally Open it will allow for changing of parameters, if it is set for Normally Closed it prevents any changes to parameters. If a input is desired to control this DIGIN X can be used. Can be set to DigiIN:X indicates on board terminal inputs, DigiIN:A:IOX:X indicates optional board inputs in A slot, DigiIN:B:IOX:X indicates optional board inputs in B slot, or Timer Channel X. RO X Function allows for having an input turn on without having to hard wire it to the physical relay output. Closed contact: all writable parameters cannot be edited.	1,2,3	RW
P2.2.27	196	Auto Control Use this parameter selecting an external input for use when desiring to use the remote control location. When this function is set for Normally Open the drive will not go into the remote control unless the keypad input is pressed. When set for Normally Closed the drive will always be in the remote location no matter the keypad loc/rem is pressed. Can be set to DigiIN:X indicates on board terminal inputs, DigiIN:A:IOX:X indicates optional board inputs in A slot, DigiIN:B:IOX:X indicates optional board inputs in B slot, or Timer Channel X. RO X Function allows for having an input turn on without having to hard wire it to the physical relay output. Closed Contact: force to remote control.	1,2,3	RW
P2.2.28	197	Hand Control Use this parameter selecting an external input for use when desiring to use the local control location. When this function is set for Normally Open the drive will not go into the local control place unless the keypad Loc/Rem button is used. When it is set for Normally Closed it will always be in the local control location no matter if the keypad loc/rem button is pressed. Can be set to DigiIN:X indicates on board terminal inputs, DigiIN:A:IOX:X indicates optional board inputs in A slot, DigiIN:B:IOX:X indicates optional board inputs in B slot, or Timer Channel X. RO X Function allows for having an input turn on without having to hard wire it to the physical relay output. Closed contact: force to local control.	1,2,3	RW
P2.2.29	209	Auto 1/2 Select Use this parameter selecting an external input for use when desiring to use the remote2 control location. This switches control and reference locations. When this function is set for Normally Open the drive will not go into the Remote 2 control place and will stay in Remote 1. When it is set for Normally Closed the drive will always be in the Remote 2 Control Place. When a DIGIN is used it will allow cycling between the 2 based off high/low state. Can be set to DigiIN:X indicates on board terminal inputs, DigiIN:A:IOX:X indicates optional board inputs in A slot, DigiIN:B:IOX:X indicates optional board inputs in B slot, or Timer Channel X. RO X Function allows for having an input turn on without having to hard wire it to the physical relay output. Closed contact: remote2 is selected as control source. Open contact: remote1 is selected as control.	1,2,3	RW
P2.2.30	2395	HOA On/Off Use this parameter for setting external input for disabling any control signal when the input is the off/open position, when closed drive will follow the desired control signal. If the function is set for Normally Open this will cause the drive to operate, if the function is set for Normally Closed then the drive will be in the off location and not allow operation. Can be set to DigiIN: X indicates on board terminal inputs, DigiIN:A:IOX:X indicates option boards in A slot, DigiIN:B:IOX:X indicates optional board in B slot, or Timer Channel X. RO X function allows for having an input turn on without having to hard wire it to the physical relay output.	1,2,3	RW
P2.2.31	217	Second Motor Para Select Use this parameter selecting an external input for use of switching between motor parameter set 1(P1 Group) and set 2 (P16 Group). When this function is set for Normally pen the drive will follow the first set of motor parameters and when the input is set for Normally Closed it will used the Second Motor Parameter set. If an input is used the function will follow the logic of the input being high/low. Can be set to DigiIN:X indicates on board terminal inputs, DigiIN:A:IOX:X indicates optional board inputs in A slot, DigiIN:B:IOX:X indicates optional board inputs in B slot, or Timer Channel X. RO X Function allows for having an input turn on without having to hard wire it to the physical relay output. Closed contact: the 2nd motor parameters is applied.	2,3	RW
P2.2.32	2312	Parameter Set1/2 Sel Use this parameter for setting external input for selecting between the stored parameter set1 or set2, this requires saving parameters to the stored sets via P21.1.3. When the function is set for Normally Open the drive will use the standard Parameter Set 1 in the keypad, if the function is set for Normally Closed the drive will follow Parameter Set 2 setting when stored to the keypad. DigiIN:A:IOX:X indicates optional board inputs in A slot, DigiIN:B:IOX:X indicates optional board inputs in B slot, or Timer Channel X. RO X Function allows for having an input turn on without having to hard wire it to the physical relay output.	1,2,3	RW

Appendix A—Description of parameters

Code	Modbus ID	Parameter	Application	RO/RW
P2.2.33	208	AI Ref Source Select Use this parameter for selecting an external input for switching between AI1 and AI2 reference signals that are located on the control board. When this function is set for Normally Open the drive will follow the AI1 input. If the function is set for Normally Close the AI2 input would then be active. Can be set to DigiIN:X indicates on board terminal inputs, DigiIN:A:IOX:X indicates optional board inputs in A slot, DigiIN:B:IOX:X indicates optional board inputs in B slot, or Timer Channel X. RO X Function allows for having an input turn on without having to hard wire it to the physical relay output. Closed contact: AI2 is selected for reference source. Open contact: AI1 is selected for reference source.	1,2,3	RW
P2.2.34	218	Bypass Start Use this parameter for selecting an external input for switching between bypass and drive modes. When this input is enabled the Bypass output contactor is enabled, when disabled this relay opens and puts drive in normal mode. When the input is enabled on the rising edge the bypass output contactor function is enabled in the output functions on the drive. When this fault is set for Normally Open/Normally Closed the drive will not activate the bypass relay output function due to the drive looking for a rising edge trigger. Can be set to DigiIN:X indicates on board terminal inputs, DigiIN:A:IOX:X indicates optional board inputs in A slot, DigiIN:B:IOX:X indicates optional board inputs in B slot, or Timer Channel X. RO X Function allows for having an input turn on without having to hard wire it to the physical relay output. Closed contact: switch to bypass. Open contact: switch to drive.	1,2,3	RW
P2.2.35	1246	Bypass Overload Use this parameter for selecting an external input for faulting frequency converter when using an external overload block, the relay would be fed into this input to fault the drive. When the function is set for Normally Open the drive will not go into the fault state, if it is set for Normally Closed the drive will go into this fault state and stay even if reset is applied. Input needs to be low to allow operation. Can be set to DigiIN:X indicates on board terminal inputs, DigiIN:A:IOX:X indicates optional board inputs in A slot, DigiIN:B:IOX:X indicates optional board inputs in B slot, or Timer Channel X. RO X Function allows for having an input turn on without having to hard wire it to the physical relay output. Closed contact: motor is over load in bypass. Use TTF method to realize the above functions.	1,2,3	RW
P2.2.36	550	PID1 Control Enable Use this parameter for selecting the digital input for turn on or off the PID1 controller. If the input is not enabled when starting the drive with PID1 Controller set as the reference the drive output will not start. Can be set to DigiIN:X indicates on board terminal inputs, DigiIN:A:IOX:X indicates optional board inputs in A slot, DigiIN:B:IOX:X indicates optional board inputs in B slot, or Timer Channel X. RO X Function allows for having an input turn on without having to hard wire it to the physical relay output. Contact Close: Enables PID 1 control mode.	2,3	RW
P2.2.37	553	PID2 Control Enable Use this parameter for selecting the digital input for turn on or off the PID2 controller. If the input is not enabled when starting the drive with PID1 Controller set as the reference the drive output will not start. Can be set to DigiIN:X indicates on board terminal inputs, DigiIN:A:IOX:X indicates optional board inputs in A slot, DigiIN:B:IOX:X indicates optional board inputs in B slot, or Timer Channel X. RO X Function allows for having an input turn on without having to hard wire it to the physical relay output. Contact Close: Enables PID 2 control mode.	2,3	RW
P2.2.38	351	PID1 Set Point Select Use this parameter for selecting an external input for selecting between Set point 1 and Set point 2 when in the PID control mode, depending on the PID Controller you are using this will all for multiple set points. When this function is set for Normally Open and the drive is in PID mode, it will use the first PID Set Point Reference. When the function is set for Normally Close the 1st PID Set Point will be active. Can be set to DigiIN:X indicates on board terminal inputs, DigiIN:A:IOX:X indicates optional board inputs in A slot, DigiIN:B:IOX:X indicates optional board inputs in B slot, or Timer Channel X. RO X Function allows for having an input turn on without having to hard wire it to the physical relay output. Closed contact: setpoint2 is selected for PID1. Open contact: setpoint1 is selected for PID1.	2,3	RW
P2.2.39	352	PID2 Set Point Select Use this parameter for selecting an external input for selecting between Set point 1 and Set point 2 when in the PID control mode, depending on the PID Controller you are using this will all for multiple set points. When this function is set for Normally Open and the drive is in PID mode, it will use the first PID Set Point Reference. When the function is set for Normally Close the 2nd PID Set Point will be active. Can be set to DigiIN:X indicates on board terminal inputs, DigiIN:A:IOX:X indicates optional board inputs in A slot, DigiIN:B:IOX:X indicates optional board inputs in B slot, or Timer Channel X. RO X Function allows for having an input turn on without having to hard wire it to the physical relay output. Closed contact: setpoint2 is selected for PID2. Open contact: setpoint1 is selected for PID2.	2,3	RW

Code	Modbus ID	Parameter	Application	RO/RW
P2.2.40	202	DC Brake Active Use this parameter for selecting an external input for enabling DC brake on a closed contact. When enabled this will cause the drive inject DC voltage into the motor to assist in bring it to a stop. When this function is set for Normally Open the drive will not activate the DC brake function. When Normally Closed is used the drive will always have the DC brake function activated. Can be set to DigiIN:X indicates on board terminal inputs, DigiIN:A:IOX:X indicates optional board inputs in A slot, DigiIN:B:IOX:X indicates optional board inputs in B slot, or Timer Channel X. RO X Function allows for having an input turn on without having to hard wire it to the physical relay output. Closed contact: DC brake function is enable.	1,2,3	RW
P2.2.41	219	Smoke Mode Use this parameter for selecting an external input for enabling the smoke purge preset speed to be enabled. When this function is set for Normally Open the drive will not activate the Smoke Mode frequency. When Normally Closed is used the drive will always run at the Smoke Purge Frequency. Can be set to DigiIN:X indicates on board terminal inputs, DigiIN:A:IOX:X indicates optional board inputs in A slot, DigiIN:B:IOX:X indicates optional board inputs in B slot, or Timer Channel X. RO X Function allows for having an input turn on without having to hard wire it to the physical relay output. Closed contact: drive is in smoke purge mode.	2,3	RW
P2.2.42	220	Fire Mode Use this parameter for selecting an external input for enabling the drive fire mode feature where faults will be ignored and preset speeds are given for reference commands to the drive, the reference are selectable in the P15 Group. When this function is set for Normally Open or Normally Closed it will depend on the setting in the Fire Mode parameter group, if the function activates on an open contact and this is set for Normally Open it will always be in the Fire Mode, if Normally Closed is used then the function will always be off. Vice versa will occur if Fire Mode is active on an Closed contact. Can be set to DigiIN:X indicates on board terminal inputs, DigiIN:A:IOX:X indicates optional board inputs in A slot, DigiIN:B:IOX:X indicates optional board inputs in B slot, or Timer Channel X. RO X Function allows for having an input turn on without having to hard wire it to the physical relay output. Closed contact: drive is in fire mode. Ignores all the faults. Note: when Fire mode is enabled, this causes the drive to ignore all faults except hardware overcurrent, STO, saturation fault. Warranty will be non valid in the case this is enabled and the drive causes issues to the system.	1,2,3	RW
P2.2.43	221	Fire Mode Ref 1/2 Select Use this parameter for selecting an external input for switching between fire mode speed reference 1 and reference 2 which is set via P15.4 and P15.5. When this function is set for Normally Open and the drive is in Fire Mode it will follow Fire Mode Ref 1, if the function is set for Normally Closed it will follow Fire Mode Ref 2. Can be set to DigiIN:X indicates on board terminal inputs, DigiIN:A:IOX:X indicates optional board inputs in A slot, DigiIN:B:IOX:X indicates optional board inputs in B slot, or Timer Channel X. RO X Function allows for having an input turn on without having to hard wire it to the physical relay output. Closed contact: drive output reference frequency selection 2	1,2,3	RW
P2.2.44	2119	Fire Mode Reverse Use this parameter for selecting an external input for enabling the motor to run in reverse when in fire mode input is enabled. when the function is set for Normally Open and not in Fire mode the drive will run as normal, when the function is set for Normally Closed and the Fire Mode input is enabled the motor will spin in the counter clockwise direction. DigiIN:X indicates on-board terminal inputs, DigiIN:A:IOX:X indicates optional board inputs in A slot and DigiIN:B:IOX:X indicates optional board inputs in B slot or Timer Channel X. RO X Function allows for having an input turn on without having to hard wire it to the physical relay output.	1,2,3	RW
P2.2.45	224	Start Timer 1 Use this parameter for selecting an external input for enabling the timer functions to begin counting. When this function is set for Normally Open the drive will not start the Timer sequence. If the function is set for Normally Close the Timer function will start. When assigned to an input the input active will start the timer. Can be set to DigiIN:X indicates on board terminal inputs, DigiIN:A:IOX:X indicates optional board inputs in A slot, DigiIN:B:IOX:X indicates optional board inputs in B slot, or Timer Channel X. RO X Function allows for having an input turn on without having to hard wire it to the physical relay output. Closed contact: Timer1,Timer2 or Timer3 will be started.	2,3	RW
P2.2.46	225	Start Timer 2 Use this parameter for selecting an external input for enabling the timer functions to begin counting. When this function is set for Normally Open the drive will not start the Timer sequence. If the function is set for Normally Close the Timer function will start. When assigned to an input the input active will start the timer. Can be set to DigiIN:X indicates on board terminal inputs, DigiIN:A:IOX:X indicates optional board inputs in A slot, DigiIN:B:IOX:X indicates optional board inputs in B slot, or Timer Channel X. RO X Function allows for having an input turn on without having to hard wire it to the physical relay output. Closed contact: Timer1,Timer2 or Timer3 will be started.	2,3	RW

Appendix A—Description of parameters

Code	Modbus ID	Parameter	Application	RO/RW
P2.2.47	226	Start Timer 3 Use this parameter for selecting an external input for enabling the timer functions to begin counting. When this function is set for Normally Open the drive will not start the Timer sequence. If the function is set for Normally Close the Timer function will start. When assigned to an input the input active will start the timer. Can be set to DigiIN:X indicates on board terminal inputs, DigiIN:A:IOX:X indicates optional board inputs in A slot, DigiIN:B:IOX:X indicates optional board inputs in B slot, or Timer Channel X. RO X Function allows for having an input turn on without having to hard wire it to the physical relay output. Closed contact: Timer1,Timer2 or Timer3 will be started.	2,3	RW
P2.3.1	105	Preset Speed 1 Use this parameter to set the Preset Frequency 1.	1,2,3	RW
P2.3.2	106	Preset Speed 2 Use this parameter to set the Preset Frequency 2.	1,2,3	RW
P2.3.3	118	Preset Speed 3 Use this parameter to set the Preset Frequency 3.	1,2,3	RW
P2.3.4	119	Preset Speed 4 Use this parameter to set the Preset Frequency 4.	1,2,3	RW
P2.3.5	120	Preset Speed 5 Use this parameter to set the Preset Frequency 5.	1,2,3	RW
P2.3.6	121	Preset Speed 6 Use this parameter to set the Preset Frequency 6.	1,2,3	RW
P2.3.7	122	Preset Speed 7 Use this parameter to set the Preset Frequency 7.	1,2,3	RW
P2.3.8	117	Jog Reference Use this parameter to set the jogging speed set point, this speed is selected with the digital input programmed for Jogging speed. When enabled the drive starts and ramps to this speed, input removed drive stops. This parameter's value is automatically limited between minimum and maximum frequency.	1,2,3	RW
P2.4.1	222	AI1 Mode Defines the analog input 1 source mode for current or voltage, also need to set DIP switches on control board SW1. 0 = 0-20mA - current loop with an external supply the ground jumper is not required. 1 = 0-10V - If using the 10V supply on Terminal 1 of the drive, it will require a ground jumper from Terminal 6 to the AI- input terminal 3.	1,2,3	RW

Figure 37. AI1 2wire-current

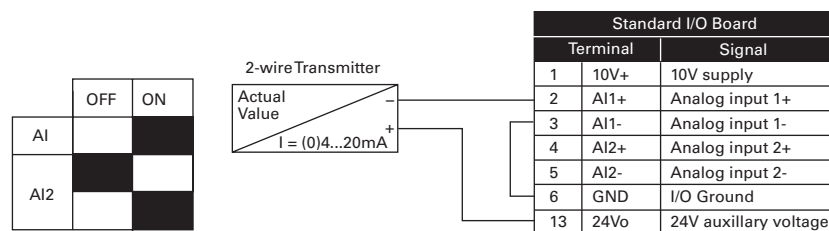
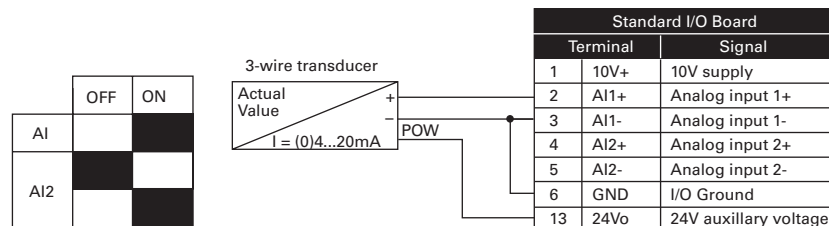

Figure 38. AI1 3wire-current



Code **Modbus ID** **Parameter** **Application** **RO/RW**

Figure 39. AI1 4wire-current

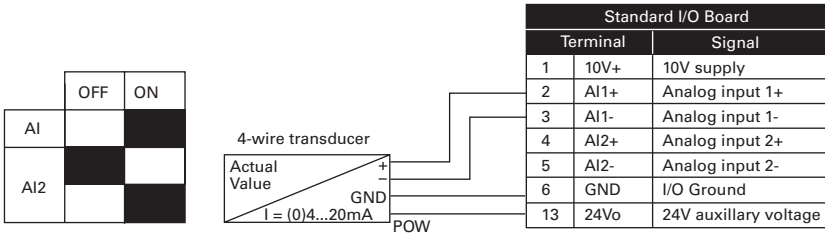
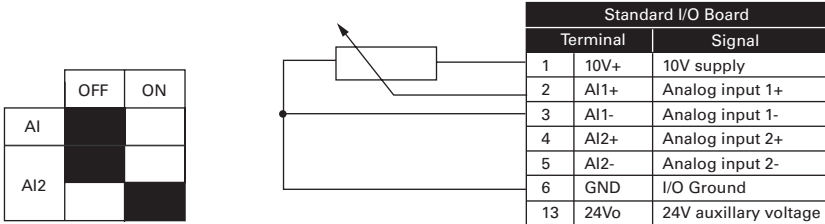

Figure 40. AI1 reference potentiometer 10V



P2.4.2 **175** **AI1 Signal Range** **1,2,3** **RW**

Configures the Analog input 1 signal source scaling.
 0 = 0-100%/0-20mA/0-10V - 0-100% is equal to 0 to 10V, 0-20mA.
 1 = 20-100%/4-20mA/2-10V - 20-100% is equal to 2 to 10V, 4-20mA.
 2 = "Customized," see parameter Para ID 176 and 177, this defines the customized signal range.

Figure 41. Analog input AI scaling

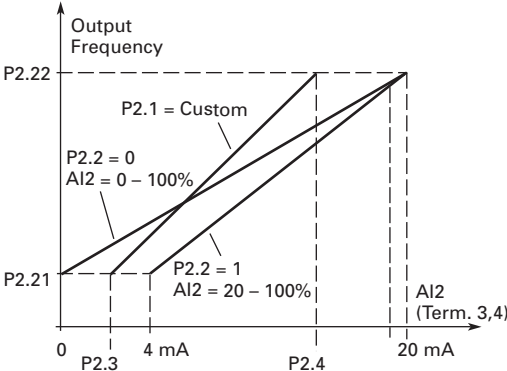

P2.4.3 **176** **AI1 Custom Min** **1,2,3** **RW**

Defines the custom minimum range of the analog input scale when the signal range is set for custom.
 AI1 Custom Min <= AI1 Custom Max.

P2.4.4 **177** **AI1 Custom Max** **1,2,3** **RW**

Defines the custom maximum range of the analog input scale when the signal range is set for custom.
 AI1 Custom Min <= AI1 Custom Max.

Appendix A—Description of parameters

Code	Modbus ID	Parameter	Application	RO/RW
P2.4.5	174	AI1 Filter Time	1,2,3	RW

When this parameter is given a value greater than 0, the function that filters out disturbances from the incoming analog signal is activated.
A long filtering time makes the regulation response slower.

Figure 42. AI1 signal filtering

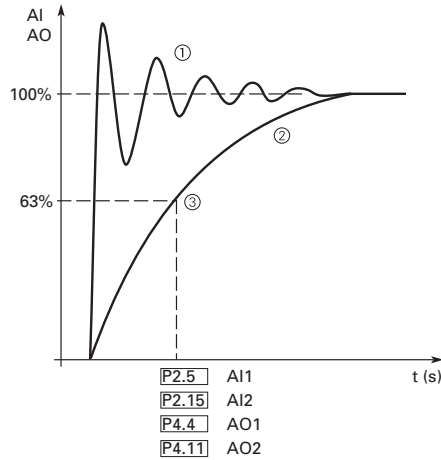

Notes:

- ☒ Analog signal with faults (unfiltered).
- ☒ Filtered analog signal.
- ☒ Filter time constant at 63% of the set value.

P2.4.6	181	AI1 Signal Invert	1,2,3	RW
--------	-----	-------------------	-------	----

This parameter is used to invert the logic of the analog input.
0 No Inversion = no inversion of analog Vin signal takes place. 0V/0(4)mA = min frequency, 10V/20mA = max frequency
1 Inverted = inversion of analog signal takes place. 0V/0(4)mA = max frequency, 10V/20mA = min frequency.

Figure 43. AI1 No signal inversion

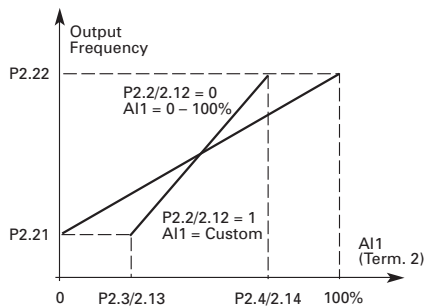
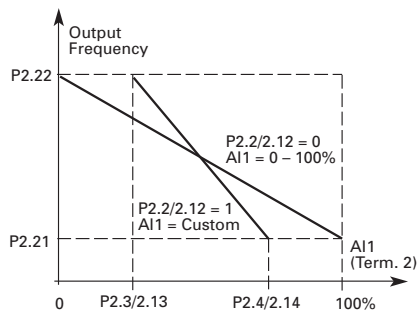

Figure 44. AI1 Signal Inversion



Maximum AI1 signal = minimum set speed.
Minimum AI1 signal = maximum set speed.

Code	Modbus ID	Parameter	Application	RO/RW
P2.4.7	178	A11 Joystick Hyst	3	RW

This parameter is used to set the analog joystick control hysteresis around the 0 speed reference. To ignore values around the 0 speed reference, set the value greater than 0%, this will cause a +/- dead band around the low analog reference. With an analog signal at 0+/- this value the reference will stay at 0Hz or min speed.

Figure 45. Example of joystick hysteresis

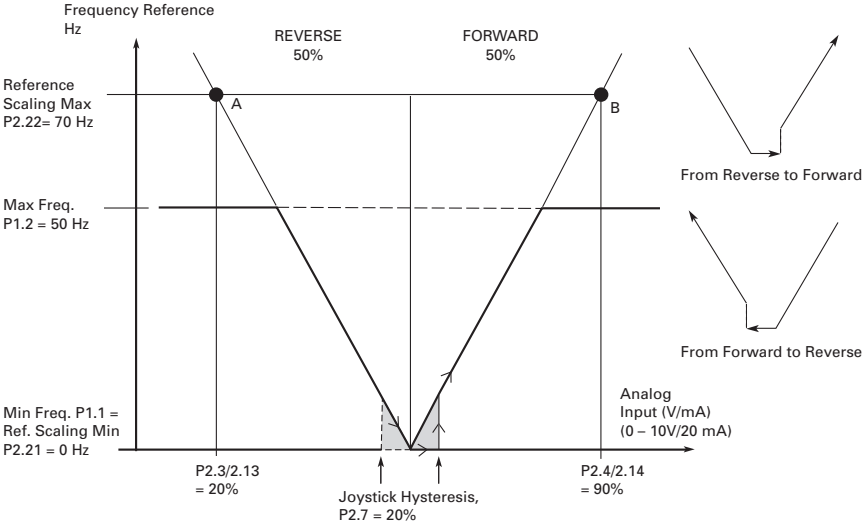

P2.4.8	179	A11 Sleep Limit	3	RW
--------	-----	-----------------	---	----

This parameter defines the sleep frequency level in the joystick control mode. The output of the drive turns off if the joystick reference stays below the sleep limit for longer than the sleep delay time parameter Para ID 180.

Figure 46. Example of sleep limit function

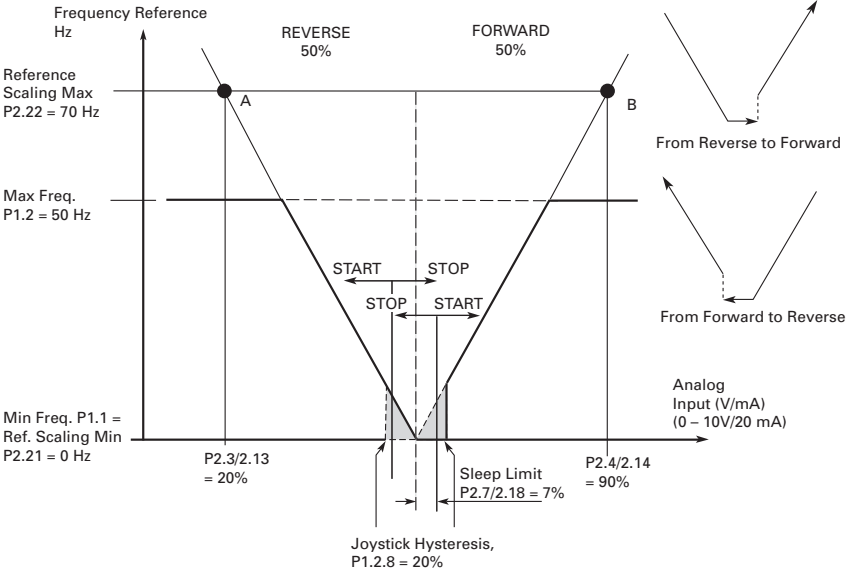

P2.4.9	180	A11 Sleep Delay	3	RW
--------	-----	-----------------	---	----

This parameter defines the joystick sleep delay time. If the joystick reference is below the sleep limit level for the time defined the output of the drive will shutoff and be in sleep mode. Sleep function is disabled when this value is set to 0.

Appendix A—Description of parameters

Code	Modbus ID	Parameter	Application	RO/RW
P2.4.10	133	AI1 Joystick Offset	3	RW

This parameter defines the mid point of the analog joystick control. By moving the offset in a positive or negative direction will cause the min frequency crossing point to be move between +/-50% of the analog input scale.

P2.5.1	223	AI2 Mode	1,2,3	RW
--------	-----	-----------------	-------	----

Defines the analog input 2 source mode for current or voltage, also need to set DIP switches on control board SW2 and 3.
 0 = 0-20mA - current loop with an external supply the ground jumper is not required.
 1 = 0-10V - If using the 10V supply on Terminal 1 of the drive, it will require a ground jumper from Terminal 6 to the AI- input terminal 3.
 2 = -10V to +10Vdc - Voltage loop with a +10 and a -10 volt differential supply.

Figure 47. AI2 2wire-current

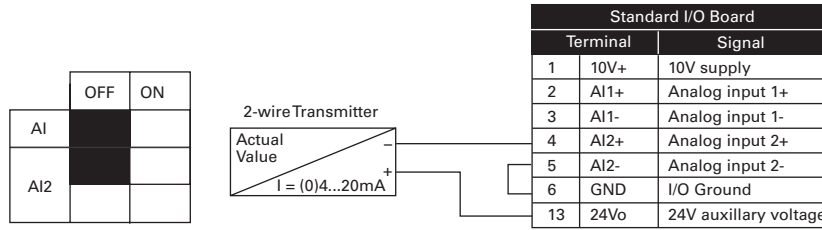

Figure 48. AI2 3wire-current

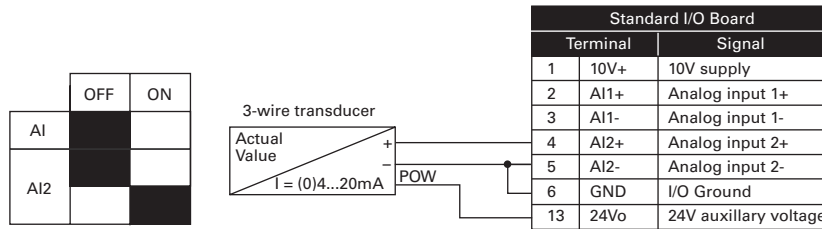

Figure 49. AI2 4wire-current

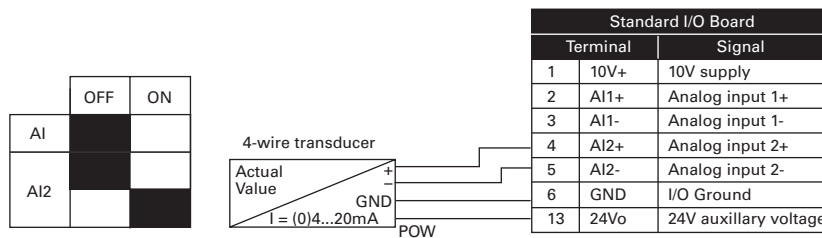
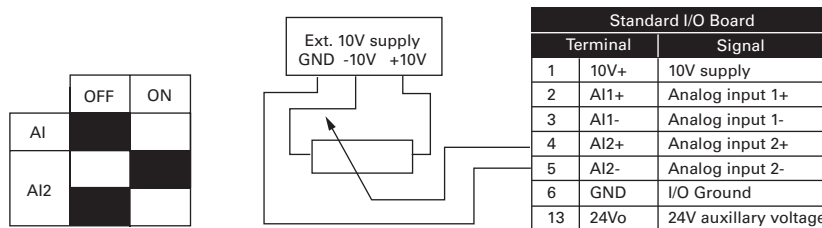
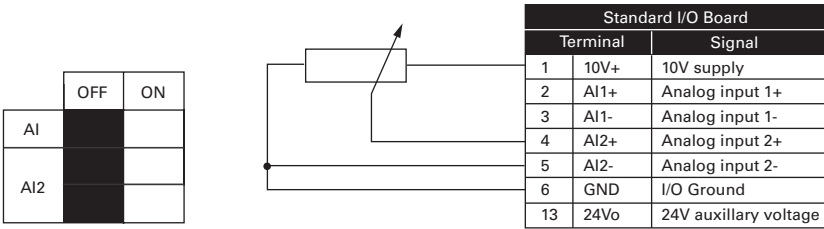

Figure 50. AI2 differential voltage



Code Modbus ID Parameter Application RO/RW

Figure 51. AI2 pot ref



P2.5.2	183	AI2 Signal Range Configures the Analog input 2 signal source scaling. 0 = 0-100%/0-20mA/0-10V - 0-100% is equal to 0 to 10V, 0-20mA 1 = 20-100%/4-20mA/2-10V - 20-100% is equal to 2 to 10V, 4-20mA. 2 = "Customized," see parameter Para ID 184 and 185, this defines the customized signal range.	1,2,3	RW
P2.5.3	184	AI2 Custom Min Defines the custom min range of the analog input scale when the signal range is set for custom. AI2Custom Min <= AI2 Custom Max.	1,2,3	RW
P2.5.4	185	AI2 Custom Max Defines the custom max range of the analog input scale when the signal range is set for custom. AI2 Custom Min <= AI2 Custom Max.	1,2,3	RW
P2.5.5	182	AI2 Filter Time When this parameter is given a value greater than 0, the function that filters out disturbances from the incoming analog signal is activated. A long filtering time makes the regulation response slower.	1,2,3	RW
P2.5.6	189	AI2 Signal Invert This parameter is used to invert the logic of the analog input. 0 No Inversion = no inversion of analog Vin signal takes place. 0V/0(4)mA = min frequency, 10V/20mA = max frequency 1 Inverted = inversion of analog signal takes place. 0V/0(4)mA = max frequency, 10V/20mA = min frequency.	1,2,3	RW
P2.5.7	186	AI2 Joystick Hyst This parameter is used to set the analog joystick control hysteresis around the 0 speed reference. To ignore values around the 0 speed reference, set the value greater than 0%, this will cause a +/- dead band around the low analog reference. With an analog signal at 0+/- this value the reference will stay at 0Hz or min speed.	3	RW
P2.5.8	187	AI2 Sleep Limit This parameter defines the sleep frequency level in the joystick control mode. The output of the drive turns off if the joystick reference stays below the sleep limit for longer than the sleep delay time parameter Para ID 188.	3	RW
P2.5.9	188	AI2 Sleep Delay This parameter defines the joystick sleep delay time. If the joystick reference is below the sleep limit level for the time defined the output of the drive will shutoff and be in sleep mode. Sleep function is disabled when this value is set to 0.	3	RW
P2.5.10	134	AI2 Joystick Offset This parameter defines the mid point of the analog joystick control. By moving the offset in a positive or negative direction will cause the min frequency crossing point to be move between +/-50% of the analog input scale.	3	RW

Appendix A—Description of parameters

Code	Modbus ID	Parameter	Application	RO/RW
P3.1.1	151	<p>D01 Function</p> <p>Use this parameter to select signal to show the digital output. Setting Value Signal Content 0 = Not Used - Out of operation 1 = Ready - Frequency converter is ready for operation 2 = Run - frequency converter is operating (motor is running) 3 = Fault - A fault trip has occurred 4 = Fault Invert - A fault trip not occurred 5 = Warning - Always if a warning exists 6 = Reverse - The reverse command has been selected 7 = At Speed - The output frequency has reached the set reference 8 = Zero Frequency - Motor output is at zero frequency 9 = Frequency limit1 Supervision - Supervision for frequency limit1 is activated 10 = Frequency limit2 Supervision - Supervision for frequency limit2 is activated 11 = PID1 Supervision - Supervision for pid1 controller is activated 12 = PID2 Supervision - Supervision for pid2 controller is activated 13 = Over Heat Warning - Drive over heat has occurred 14 = Over Current Regular - Over current regulator is enabled 15 = Over Volt Regular - Over volt regulator is enabled 16 = Under Volt Regular - Under volt regulator is enabled 17 = 4 mA Fault - 4 mA fault has occurred 20 = Torque Limit Supervision - Supervision for torque limit 21 = Reference Limit Supervision - Supervision for reference limit 22 = Control from IO - I/O is the control place 23 = Unrequired Rotation Direction - The active direction isn't the same with the reference direction 24 = Thermal Fault - Thermal fault has occurred 25 = Fire Mode - Drive is in fire mode 26 = Bypass Running - Drive is in bypass mode 27 = External Fault - External fault has occurred 28 = Remote Control - Remote is the control place 29 = Jog Speed - Drive is in jog mode 30 = Motor Thermal Protection - Motor is thermal protected 31 = Fieldbus Input1 - Controlled by FB control word, look at com manuals. 32 = Fieldbus Input2 - Controlled by FB control word, look at com manuals. 33 = Fieldbus Input3 - Controlled by FB control word, look at com manuals. 34 = Fieldbus Intpu4 - Controlled by FB control word, look at com manuals. 35 = Damper Control - Drive is in damper control 36 = Timer1 Status - The status of timer1 37 = Timer2 Status - The status of timer2 38 = Timer3 Status - The status of timer3 40 = Power Limit Supervision - Supervision for power limit 41 = Temperature Limit Supervision - Supervision for temperature limit 42 = Analog Input Supervision - Supervision for analog input 43 = Motor1 Control - Motor1 is controlled 48 = Logic Fulfilled - The status of logic function 49 = PID1 Sleep - PID1 controller is in sleep mode 50 = PID2 Sleep - PID2 controller is in sleep mode 51 = Motor Current 1 Supv - Motor current supervision value active 52 = Motor Current 2 Supv - Motor current supervision value active 53 = Second AI Limit Supv - Analog input supervision active 54 = DC Charge Switch Close - DC bus is charged (230VAC - 230VDC, 480VAC - 380VDC, 575VAC - 520VDC) fault signal is not effective by this output. 55 = Preheat Active - Preheat Control mode is activated 56 = Cold Weather Active - Cold Weather mode is activated 58 = 2th Stage Ramp Frequency Active - 2nd stage ramp frequency limit reached 59 = STO Fault Output - STO fault is active 60 = Run Bypass/Drive - Run indication for drive and bypass. 61 = Bypass Overload - Bypass Overload fault input is enabled. 62 = Bypass Run - Drive run command for bypass is given</p>	1,2,3	RW

Code	Modbus ID	Parameter	Application	RO/RW
P3.1.2	152	<p>R01 Function</p> <p>Use this parameter to select signal to show the digital output. Setting Value Signal Content 0 = Not Used - Out of operation 1 = Ready - Frequency converter is ready for operation 2 = Run - frequency converter is operating (motor is running) 3 = Fault - A fault trip has occurred 4 = Fault Invert - A fault trip not occurred 5 = Warning - Always if a warning exists 6 = Reverse - The reverse command has been selected 7 = At Speed - The output frequency has reached the set reference 8 = Zero Frequency - Motor output is at zero frequency 9 = Frequency limit1 Supervision - Supervision for frequency limit1 is activated 10 = Frequency limit2 Supervision - Supervision for frequency limit2 is activated 11 = PID1 Supervision - Supervision for pid1 controller is activated 12 = PID2 Supervision - Supervision for pid2 controller is activated 13 = Over Heat Warning - Drive over heat has occurred 14 = Over Current Regular - Over current regulator is enabled 15 = Over Volt Regular - Over volt regulator is enabled 16 = Under Volt Regular - Under volt regulator is enabled 17 = 4 mA Fault - 4 mA fault has occurred 20 = Torque Limit Supervision - Supervision for torque limit 21 = Reference Limit Supervision - Supervision for reference limit 22 = Control from IO - I/O is the control place 23 = Unrequired Rotation Direction - The active direction isn't the same with the reference direction 24 = Thermal Fault - Thermal fault has occurred 25 = Fire Mode - Drive is in fire mode 26 = Bypass Running - Drive is in bypass mode 27 = External Fault - External fault has occurred 28 = Remote Control - Remote is the control place 29 = Jog Speed - Drive is in jog mode 30 = Motor Thermal Protection - Motor is thermal protected 31 = Fieldbus Input1 - Controlled by FB control word, look at com manuals. 32 = Fieldbus Input2 - Controlled by FB control word, look at com manuals. 33 = Fieldbus Input3 - Controlled by FB control word, look at com manuals. 34 = Fieldbus Intpu4 - Controlled by FB control word, look at com manuals. 35 = Damper Control - Drive is in damper control 36 = Timer1 Status - The status of timer1 37 = Timer2 Status - The status of timer2 38 = Timer3 Status - The status of timer3 40 = Power Limit Supervision - Supervision for power limit 41 = Temperature Limit Supervision - Supervision for temperature limit 42 = Analog Input Supervision - Supervision for analog input 43 = Motor1 Control - Motor1 is controlled 48 = Logic Fulfilled - The status of logic function 49 = PID1 Sleep - PID1 controller is in sleep mode 50 = PID2 Sleep - PID2 controller is in sleep mode 51 = Motor Current 1 Supv - Motor current supervision value active 52 = Motor Current 2 Supv - Motor current supervision value active 53 = Second AI Limit Supv - Analog input supervision active 54 = DC Charge Switch Close - DC bus is charged (230VAC - 230VDC, 480VAC - 380VDC, 575VAC - 520VDC) fault signal is not effective by this output. 55 = Preheat Active - Preheat Control mode is activated 56 = Cold Weather Active - Cold Weather mode is activated 58 = 2th Stage Ramp Frequency Active - 2nd stage ramp frequency limit reached 59 = STO Fault Output - STO fault is active 60 = Run Bypass/Drive - Run indication for drive and bypass. 61 = Bypass Overload - Bypass Overload fault input is enabled. 62 = Bypass Run - Drive run command for bypass is given</p>	1,2,3	RW
P3.1.3	2112	<p>R01 On Delay</p> <p>Use this parameter to set the delay time for R01 relay to transition from logic 0 to 1 state.</p>	1,2,3	RW
P3.1.4	2113	<p>R01 Off Delay</p> <p>Use this parameter to set the delay time for R01 relay to transition from logic 1 to 0 state.</p>	1,2,3	RW

Appendix A—Description of parameters

Code	Modbus ID	Parameter	Application	RO/RW
P3.1.5	153	<p>R02 Function</p> <p>Use this parameter to select signal to show the digital output. Setting Value Signal Content</p> <p>0 = Not Used - Out of operation 1 = Ready - Frequency converter is ready for operation 2 = Run - frequency converter is operating (motor is running) 3 = Fault - A fault trip has occurred 4 = Fault Invert - A fault trip not occurred 5 = Warning - Always if a warning exists 6 = Reverse - The reverse command has been selected 7 = At Speed - The output frequency has reached the set reference 8 = Zero Frequency - Motor output is at zero frequency 9 = Frequency limit1 Supervision - Supervision for frequency limit1 is activated 10 = Frequency limit2 Supervision - Supervision for frequency limit2 is activated 11 = PID1 Supervision - Supervision for pid1 controller is activated 12 = PID2 Supervision - Supervision for pid2 controller is activated 13 = Over Heat Warning - Drive over heat has occurred 14 = Over Current Regular - Over current regulator is enabled 15 = Over Volt Regular - Over volt regulator is enabled 16 = Under Volt Regular - Under volt regulator is enabled 17 = 4 mA Fault - 4 mA fault has occurred 20 = Torque Limit Supervision - Supervision for torque limit 21 = Reference Limit Supervision - Supervision for reference limit 22 = Control from IO - I/O is the control place 23 = Unrequired Rotation Direction - The active direction isn't the same with the reference direction 24 = Thermal Fault - Thermal fault has occurred 25 = Fire Mode - Drive is in fire mode 26 = Bypass Running - Drive is in bypass mode 27 = External Fault - External fault has occurred 28 = Remote Control - Remote is the control place 29 = Jog Speed - Drive is in jog mode 30 = Motor Thermal Protection - Motor is thermal protected 31 = Fieldbus Input1 - Controlled by FB control word, look at com manuals. 32 = Fieldbus Input2 - Controlled by FB control word, look at com manuals. 33 = Fieldbus Input3 - Controlled by FB control word, look at com manuals. 34 = Fieldbus Intpu4 - Controlled by FB control word, look at com manuals. 35 = Damper Control - Drive is in damper control 36 = Timer1 Status - The status of timer1 37 = Timer2 Status - The status of timer2 38 = Timer3 Status - The status of timer3 40 = Power Limit Supervision - Supervision for power limit 41 = Temperature Limit Supervision - Supervision for temperature limit 42 = Analog Input Supervision - Supervision for analog input 43 = Motor1 Control - Motor1 is controlled 48 = Logic Fulfilled - The status of logic function 49 = PID1 Sleep - PID1 controller is in sleep mode 50 = PID2 Sleep - PID2 controller is in sleep mode 51 = Motor Current 1 Supv - Motor current supervision value active 52 = Motor Current 2 Supv - Motor current supervision value active 53 = Second AI Limit Supv - Analog input supervision active 54 = DC Charge Switch Close - DC bus is charged (230VAC - 230VDC, 480VAC - 380VDC, 575VAC - 520VDC) fault signal is not effective by this output. 55 = Preheat Active - Preheat Control mode is activated 56 = Cold Weather Active - Cold Weather mode is activated 58 = 2th Stage Ramp Frequency Active - 2nd stage ramp frequency limit reached 59 = STO Fault Output - STO fault is active 60 = Run Bypass/Drive - Run indication for drive and bypass. 61 = Bypass Overload - Bypass Overload fault input is enabled. 62 = Bypass Run - Drive run command for bypass is given</p>	1,2,3	RW
P3.1.6	2114	<p>R02 On Delay</p> <p>Use this parameter to set the delay time for R02 relay to transition from logic 0 to 1 state.</p>	1,2,3	RW
P3.1.7	2115	<p>R02 Off Delay</p> <p>Use this parameter to set the delay time for R02 relay to transition from logic 1 to 0 state.</p>	1,2,3	RW

Code	Modbus ID	Parameter	Application	RO/RW
P3.1.8	538	<p>R03 Function</p> <p>Use this parameter to select signal to show the digital output. Setting Value Signal Content</p> <p>0 = Not Used - Out of operation 1 = Ready - Frequency converter is ready for operation 2 = Run - frequency converter is operating (motor is running) 3 = Fault - A fault trip has occurred 4 = Fault Invert - A fault trip not occurred 5 = Warning - Always if a warning exists 6 = Reverse - The reverse command has been selected 7 = At Speed - The output frequency has reached the set reference 8 = Zero Frequency - Motor output is at zero frequency 9 = Frequency limit1 Supervision - Supervision for frequency limit1 is activated 10 = Frequency limit2 Supervision - Supervision for frequency limit2 is activated 11 = PID1 Supervision - Supervision for pid1 controller is activated 12 = PID2 Supervision - Supervision for pid2 controller is activated 13 = Over Heat Warning - Drive over heat has occurred 14 = Over Current Regular - Over current regulator is enabled 15 = Over Volt Regular - Over volt regulator is enabled 16 = Under Volt Regular - Under volt regulator is enabled 17 = 4 mA Fault - 4 mA fault has occurred 20 = Torque Limit Supervision - Supervision for torque limit 21 = Reference Limit Supervision - Supervision for reference limit 22 = Control from IO - I/O is the control place 23 = Unrequired Rotation Direction - The active direction isn't the same with the reference direction 24 = Thermal Fault - Thermal fault has occurred 25 = Fire Mode - Drive is in fire mode 26 = Bypass Running - Drive is in bypass mode 27 = External Fault - External fault has occurred 28 = Remote Control - Remote is the control place 29 = Jog Speed - Drive is in jog mode 30 = Motor Thermal Protection - Motor is thermal protected 31 = Fieldbus Input1 - Controlled by FB control word, look at com manuals. 32 = Fieldbus Input2 - Controlled by FB control word, look at com manuals. 33 = Fieldbus Input3 - Controlled by FB control word, look at com manuals. 34 = Fieldbus Intpu4 - Controlled by FB control word, look at com manuals. 35 = Damper Control - Drive is in damper control 36 = Timer1 Status - The status of timer1 37 = Timer2 Status - The status of timer2 38 = Timer3 Status - The status of timer3 40 = Power Limit Supervision - Supervision for power limit 41 = Temperature Limit Supervision - Supervision for temperature limit 42 = Analog Input Supervision - Supervision for analog input 43 = Motor1 Control - Motor1 is controlled 48 = Logic Fulfilled - The status of logic function 49 = PID1 Sleep - PID1 controller is in sleep mode 50 = PID2 Sleep - PID2 controller is in sleep mode 51 = Motor Current 1 Supv - Motor current supervision value active 52 = Motor Current 2 Supv - Motor current supervision value active 53 = Second AI Limit Supv - Analog input supervision active 54 = DC Charge Switch Close - DC bus is charged (230VAC - 230VDC, 480VAC - 380VDC, 575VAC - 520VDC) fault signal is not effective by this output. 55 = Preheat Active - Preheat Control mode is activated 56 = Cold Weather Active - Cold Weather mode is activated 58 = 2th Stage Ramp Frequency Active - 2nd stage ramp frequency limit reached 59 = STO Fault Output - STO fault is active 60 = Run Bypass/Drive - Run indication for drive and bypass. 61 = Bypass Overload - Bypass Overload fault input is enabled. 62 = Bypass Run - Drive run command for bypass is given</p>	1,2,3	RW
P3.1.9	2116	<p>R03 On Delay</p> <p>Use this parameter to set the delay time for R03 relay to transition from logic 0 to 1 state.</p>	1,2,3	RW
P3.1.10	2117	<p>R03 Off Delay</p> <p>Use this parameter to set the delay time for R03 relay to transition from logic 1 to 0 state.</p>	1,2,3	RW
P3.1.11	2118	<p>R03 Reverse</p> <p>Use this parameter to invert the output logic of R03 to be normally closed. Instead of normally open. Power off state of relay will be Normally Open.</p> <p>1 = Not Inverted 2 = Inverted</p>	1,2,3	RW

Appendix A—Description of parameters

Code	Modbus ID	Parameter	Application	RO/RW
P3.1.12	2463	<p>Virtual R01 Function</p> <p>Use this parameter to select the function of output relay VO1. This relay is a internal relay that can be used to tie to internal functions in the drive. The functions are the same with the standard hardware relays.</p> <p>Setting Value Signal Content</p> <p>0 = not used - Out of operation 1 = ready - Frequency converter is ready for operation 2 = run F - frequency converter is operating (motor is running) 3 = fault - A fault trip has occurred 4 = fault invert - A fault trip not occurred 5 = warning - Always if a warning exists 6 = reverse - The reverse command has been selected 7 = at speed - The output frequency has reached the set reference 8 = zero frequency - Motor output is at zero frequency 9 = frequency limit1 supervision - Supervision for frequency limit1 is activated 10 = frequency limit2 supervision - Supervision for frequency limit2 is activated 11 = pid1 supervision - Supervision for pid1 controller is activated 12 = pid2 supervision - Supervision for pid2 controller is activated 13 = over heat warning - Drive over heat has occurred 14 = over current regular - Over current regulator is enabled 15 = over volt regular - Over volt regulator is enabled 16 = under volt regular - Under volt regulator is enabled 17 = 4 mA fault - 4 mA fault has occurred 20 = torque limit supervision - Supervision for torque limit 21 = reference limit supervision - Supervision for reference limit 22 = control from IO - I/O is the control place 23 = unrequired rotation direction - The active direction isn't the same with the reference direction 24 = thermal fault - Thermal fault has occurred 25 = fire mode - Drive is in fire mode 26 = bypass running - Drive is in bypass mode 27 = external fault - External fault has occurred 28 = remote control - Remote is the control place 29 = jog speed - Drive is in jog mode 30 = motor thermal protection - Motor is thermal protected 31 = fieldbus input1 - Controlled by FB control word, look at com manuals. 32 = fieldbus input2 - Controlled by FB control word, look at com manuals. 33 = fieldbus input3 - Controlled by FB control word, look at com manuals. 34 = fieldbus intpu4 - Controlled by FB control word, look at com manuals. 35 = damper control - Drive is in damper control 36 = timer1 status - The status of timer1 37 = timer2 status - The status of timer2 38 = timer3 status - The status of timer3 40 = power limit supervision - Supervision for power limit 41 = temperature limit supervision - Supervision for temperature limit 42 = analog input supervision - Supervision for analog input 43 = motor1 control - Motor1 is controlled 48 = logic fulfilled - The status of logic function 49 = pid1 sleep - PID1 controller is in sleep mode 50 = pid2 sleep - PID2 controller is in sleep mode 51 = Motor Current 1 Supv - Motor current supervision value active 52 = Motor Current 2 Supv - Motor current supervision value active 53 = Second AI Limit Supv - Analog input supervision active 54 = DC Charge Switch Close - DC bus is charged (230VAC - 230VDC, 480VAC - 380VDC, 575VAC - 520VDC) fault signal is not effective by this output. 55 = Preheat Active - Preheat Control mode is activated 56 = Cold Weather Active - Cold Weather mode is activated 58 = 2th Stage Ramp Frequency Active - 2nd stage ramp frequency limit reached 59 = STO Fault Output - STO fault is active 60 = Run Bypass/Drive - Run indication for drive and bypass. 61 = Bypass Overload - Bypass Overload fault input is enabled. 62 = Bypass Run - Drive run command for bypass is given</p>	1,2,3	RW

Code	Modbus ID	Parameter	Application	RO/RW
P3.1.13	2464	<p>Virtual R02 Function</p> <p>Use this parameter to select the function of output relay V02. This relay is a internal relay that can be used to tie to internal functions in the drive. The functions are the same with the standard hardware relays.</p> <p>Setting Value Signal Content</p> <p>0 = not used - Out of operation</p> <p>1 = ready - Frequency converter is ready for operation</p> <p>2 = run F - frequency converter is operating (motor is running)</p> <p>3 = fault - A fault trip has occurred</p> <p>4 = fault invert - A fault trip not occurred</p> <p>5 = warning - Always if a warning exists</p> <p>6 = reverse - The reverse command has been selected</p> <p>7 = at speed - The output frequency has reached the set reference</p> <p>8 = zero frequency - Motor output is at zero frequency</p> <p>9 = frequency limit1 supervision - Supervision for frequency limit1 is activated</p> <p>10 = frequency limit2 supervision - Supervision for frequency limit2 is activated</p> <p>11 = pid1 supervision - Supervision for pid1 controller is activated</p> <p>12 = pid2 supervision - Supervision for pid2 controller is activated</p> <p>13 = over heat warning - Drive over heat has occurred</p> <p>14 = over current regular - Over current regulator is enabled</p> <p>15 = over volt regular - Over volt regulator is enabled</p> <p>16 = under volt regular - Under volt regulator is enabled</p> <p>17 = 4 mA fault - 4 mA fault has occurred</p> <p>20 = torque limit supervision - Supervision for torque limit</p> <p>21 = reference limit supervision - Supervision for reference limit</p> <p>22 = control from IO - I/O is the control place</p> <p>23 = unrequired rotation direction - The active direction isn't the same with the reference direction</p> <p>24 = thermal fault - Thermal fault has occurred</p> <p>25 = fire mode - Drive is in fire mode</p> <p>26 = bypass running - Drive is in bypass mode</p> <p>27 = external fault - External fault has occurred</p> <p>28 = remote control - Remote is the control place</p> <p>29 = jog speed - Drive is in jog mode</p> <p>30 = motor thermal protection - Motor is thermal protected</p> <p>31 = fieldbus input1 - Controlled by FB control word, look at com manuals.</p> <p>32 = fieldbus input2 - Controlled by FB control word, look at com manuals.</p> <p>33 = fieldbus input3 - Controlled by FB control word, look at com manuals.</p> <p>34 = fieldbus intpu4 - Controlled by FB control word, look at com manuals.</p> <p>35 = damper control - Drive is in damper control</p> <p>36 = timer1 status - The status of timer1</p> <p>37 = timer2 status - The status of timer2</p> <p>38 = timer3 status - The status of timer3</p> <p>40 = power limit supervision - Supervision for power limit</p> <p>41 = temperature limit supervision - Supervision for temperature limit</p> <p>42 = analog input supervision - Supervision for analog input</p> <p>43 = motor1 control - Motor1 is controlled</p> <p>48 = logic fulfilled - The status of logic function</p> <p>49 = pid1 sleep - PID1 controller is in sleep mode</p> <p>50 = pid2 sleep - PID2 controller is in sleep mode</p> <p>51 = Motor Current 1 Supv - Motor current supervision value active</p> <p>52 = Motor Current 2 Supv - Motor current supervision value active</p> <p>53 = Second AI Limit Supv - Analog input supervision active</p> <p>54 = DC Charge Switch Close - DC bus is charged (230VAC - 230VDC, 480VAC - 380VDC, 575VAC - 520VDC) fault signal is not effective by this output.</p> <p>55 = Preheat Active - Preheat Control mode is activated</p> <p>56 = Cold Weather Active - Cold Weather mode is activated</p> <p>58 = 2th Stage Ramp Frequency Active - 2nd stage ramp frequency limit reached</p> <p>59 = STO Fault Output - STO fault is active</p> <p>60 = Run Bypass/Drive - Run indication for drive and bypass.</p> <p>61 = Bypass Overload - Bypass Overload fault input is enabled.</p> <p>62 = Bypass Run - Drive run command for bypass is given</p>	1,2,3	RW
P3.2.1	154	<p>Freq Limit 1 Supv</p> <p>Use this parameter to select how the frequency converter supervision controller functions as either a high or low limit based off the set supervision value. It can also be used to enabled an external brake control relay.</p> <p>0 = No supervision</p> <p>1 = Low limit supervision</p> <p>2 = High limit supervision</p> <p>3 = Brake-on control</p>	1,2,3	RW

Appendix A—Description of parameters

Code	Modbus ID	Parameter	Application	RO/RW
P3.2.2	155	Freq Limit 1 Supv Val Use this parameter to select the frequency value supervised by Para ID 154. If the output frequency goes under/over the set limit, this function generates a warning message via the digital output DO1 or relay outputs RO1 or RO2 or RO3 .	1,2,3	RW
Figure 52. Supervision function				
P3.2.3	2200	Freq Limit 1 Supv Hyst Use this parameter to define the hysteresis value between when the Output Frequency supervision enables and disables itself. This value is in reference from distance away form the defined limit value.	1,2,3	RW
P3.2.4	157	Freq Limit 2 Supv Use this parameter to select how the frequency converter supervision controller functions as either a high or low limit based off the set supervision value. It can also be used to enabled/disabled an external brake control relay. 0 <tab> No limit 1 = Low limit supervision 2 = High limit supervision 3 = Brake-off control 4 = Brake-on/off control	1,2,3	RW
P3.2.5	158	Freq Limit 2 Supv Val Use this parameter to select the frequency value supervised by Para ID 157. If the output frequency goes under/over the set limit, this function generates a warning message via the digital output DO1 or relay outputs RO1 or RO2 or RO3.	1,2,3	RW
P3.2.6	2201	Freq Limit 2 Supv Hyst Use this parameter to define the hysteresis value between when the Output Frequency supervision enables and disables itself. This value is in reference from distance away form the defined limit value.	1,2,3	RW
P3.2.7	159	Torque Limit Supv Use this parameter to select how the frequency converter functions upon the torque limit supervision value being met as a high or low limit. It can also control a mechanical brake to disable once torque is built up with the motor (Torque proofing). 0 = No limit 1 = Low limit supervision 2 = High limit supervision 3 = Brake-off control	1,2,3	RW
P3.2.8	160	Torque Limit Supv Val Use this parameter to select the torque value to be supervised by Para ID 159. If the output frequency goes under/over the set limit, this function generates a warning message via the digital output DO1 or via the relay outputs RO1 or RO2 or RO3.	1,2,3	RW
P3.2.9	2202	Torque Limit Supv Hyst Use this parameter to define the hysteresis value between when the Torque supervision enables and disables itself. This value is in reference from distance away form the defined limit value.	1,2,3	RW

Code	Modbus ID	Parameter	Application	RO/RW
P3.2.10	161	Ref Limit Supv Use this parameter to select how the frequency converter functions upon the reference supervision value being a high or low limit. 0 = No supervision 1 = Low limit supervision 2 = High limit supervision	1,2,3	RW
P3.2.11	162	Ref Limit Supv Val Use this parameter to select the frequency value to be supervised by Para ID 161. If the output frequency goes under/over the set limit, this function generates a warning message via the digital output DO1 or via the relay outputs RO1 or RO2 or RO3.	1,2,3	RW
P3.2.12	2203	Ref Limit Supv Hyst Use this parameter to define the hysteresis value between when the Reference limit supervision enables and disables itself. This value is in reference from distance away form the defined limit value.	1,2,3	RW
P3.2.13	165	Temp Limit Supv Use this parameter to select how the frequency converter functions upon the value setting based off the Drive Temperature. 0 = No supervision 1 = Low limit supervision 2 = High limit supervision	1,2,3	RW
P3.2.14	166	Temp Limit Supv Val Use this parameter to select the temperature value to be supervised by Para ID 165. If the temperature of the frequency converter unit falls below or exceeds the set limit, this function generates a warning message via the digital output DO1 or via a relay output RO1, RO2 or RO3.	1,2,3	RW
P3.2.15	2204	Temp Limit Supv Hyst Use this parameter to define the hysteresis value between when the Temp limit supervision enables and disables itself. This value is in reference from distance away form the defined limit value.	1,2,3	RW
P3.2.16	167	Power Limit Supv Use this parameter to select how the frequency converter functions based off the power monitor upon the limit value setting 0 = No supervision 1 = Low limit supervision 2 = High limit supervision	1,2,3	RW
P3.2.17	168	Power Limit Supv Val Use this parameter to select the power value to be supervised by Para ID 167. If the calculated power value falls below or exceeds the set limit, this function generates a warning message via the digital output DO1 or via a relay output RO1, RO2 or RO3.	1,2,3	RW
P3.2.18	2205	Power Limit Supv Hyst Use this parameter to define the hysteresis value between when the Power limit supervision enables and disables itself. This value is in reference from distance away form the defined limit value.	1,2,3	RW
P3.2.19	170	AI Supv Select Use this parameter to select an analog signal to use for the analog input supervision 0 = Analog reference from AI1 (terminals 2 and 3, e.g., potentiometer) 1 = Analog reference from AI2 (terminals 4 and 5, e.g., transducer)	1,2,3	RW
P3.2.20	171	AI Limit Supv Use this parameter to select how the frequency converter functions based off the analog input limit value setting 0 = No supervision 1 = Low limit supervision 2 = High limit supervision	1,2,3	RW
P3.2.21	172	AI Limit Supv Val Use this parameter to select the analog input value to be supervised by Para ID 171. If the value of the selected analog input goes under/over the set limit, this function generates a warning message via the digital output DO1 or via a relay output RO1, RO2 or RO3.	1,2,3	RW
P3.2.22	2198	AI Supv Hyst Use this parameter to define the hysteresis value between when the AI supervision enables and disables itself. This value is in reference from distance away form the defined limit value.	1,2,3	RW

Appendix A—Description of parameters

Code	Modbus ID	Parameter	Application	RO/RW
P3.2.23	2189	Motor Current 1 Supv Use this parameter to select how the frequency converter functions based off the motor current supervision. The drive monitors the active motor current and based of this supervision will enable itself based off the supervision value. 0 = No supervision 1 = Low limit supervision 2 = High limit supervision 3 = Brake Off Control	1,2,3	RW
P3.2.24	2190	Motor Current 1 Supv Value Use this parameter to select the current level used for the supervision setting. If the value of the selected analog input goes under/over the defined value, this function generates a warning message through the digital output or the relay output.	1,2,3	RW
P3.2.25	2196	Motor Current 1 Supv Hyst Use this parameter to define the hysteresis value between when the motor current 1 supervision enables and disables itself. This value is in reference from distance away form the defined limit value.	1,2,3	RW
P3.2.26	2191	Motor Current 2 Supv Use this parameter to select how the frequency converter functions based off the motor current supervision. The drive monitors the active motor current and will enable itself based off the supervision value. 0 = No supervision 1 = Low limit supervision 2 = High limit supervision 3 = Brake Off Control	1,2,3	RW
P3.2.27	2192	Motor Current 2 Supv Value Use this parameter to select the current level used for the supervision setting. If the value of the selected analog input goes under/over the defined value, this function generates a warning message through the digital output or the relay output.	1,2,3	RW
P3.2.28	2197	Motor Current 2 Supv Hyst Use this parameter to define the hysteresis value between when the motor current 1 supervision enables and disables itself. This value is in reference from distance away form the defined limit value.	1,2,3	RW
P3.2.29	2193	Second AI Supv Select Use this parameter to select an analog signal to use for the analog input supervision 0 = Analog reference from AI1 (terminals 2 and 3, e.g., potentiometer) 1 = Analog reference from AI2 (terminals 4 and 5, e.g., transducer)	1,2,3	RW
P3.2.30	2194	Second AI Limit Supv Use this parameter to select how the frequency converter functions based off the analog input limit value setting 0 = No supervision 1 = Low limit supervision 2 = High limit supervision	1,2,3	RW
P3.2.31	2195	Second AI Limit Supv Val Use this parameter to select the analog input value to be supervised by Para ID 2194. If the value of the selected analog input goes under/over the set limit, this function generates a warning message via the digital output DO1 or via a relay output RO1, RO2 or RO3.	1,2,3	RW
P3.2.32	2199	Second AI Supv Hyst Use this parameter to define the hysteresis value between when the AI supervision enables and disables itself. This value is in reference from distance away form the defined limit value.	1,2,3	RW
P3.2.33	1346	PID1 Superv Enable Use this parameter to select enabling of the upper and lower limits around the reference are set. When the actual value goes above or below these, a counter starts counting up toward the Delay. When the actual value is within the allowed area, the same counter counts down instead. After the delay time it will turn on an relay output value.	2,3	RW
P3.2.34	1347	PID1 Superv Upper Limit Use this parameter to set the upper PID feedback supervision limit level.	2,3	RW
P3.2.35	1349	PID1 Superv Lower Limit Use this parameter to set the lower PID feedback supervision limit level.	2,3	RW

Code	Modbus ID	Parameter	Application	RO/RW
P3.2.36	1351	PID1 Superv Delay Use this parameter to set the delay time after which the PID feedback goes above or below the limit settings to provide status to relay output function.	2,3	RW
P3.2.37	1408	PID2 Superv Enable Use this parameter to select enabling of the upper and lower limits around the reference are set. When the actual value goes above or below these, a counter starts counting up toward the Delay. When the actual value is within the allowed area, the same counter counts down instead. After the delay time it will turn on an relay output value.	2,3	RW
P3.2.38	1409	PID2 Superv Upper Limit Use this parameter to set the upper PID feedback supervision limit level.	2,3	RW
P3.2.39	1411	PID2 Superv Lower Limit Use this parameter to set the lower PID feedback supervision limit level.	2,3	RW
P3.2.40	1413	PID2 Superv Delay Use this parameter to set the delay time after which the PID feedback goes above or below the limit settings to provide status to relay output function.	2,3	RW
P3.3.1	227	A01 Mode Use this parameter to select the analog output mode for AO1 to be current or voltage. There are internal relays to perform the switching of the signal between mA or V.	1,2,3	RW
P3.3.2	146	A01 Function Use this parameter to select the function or signal that is connected to the terminal AO1 terminal 22. Scaling will very based on the signal selected.	1,2,3	RW
P3.3.3	149	A01 Minimum Use this parameter to define the signal minimum range setting to be either 0 mA or 4 mA (AO1 mode = 0–20 mA); 0V or 2V (AO1 mode = 0–10V). 0 = Set minimum value to 0V/0 mA. 1 = Set minimum value to 2V/4 mA.	1,2,3	RW
P3.3.4	147	A01 Filter Time Use this parameter to define the filtering time for the analog output signal, with a higher number the more filtering time is added on the output signal. Setting this parameter value to 0.00 will deactivate filtering.	1,2,3	RW

Figure 53. Analog output filtering

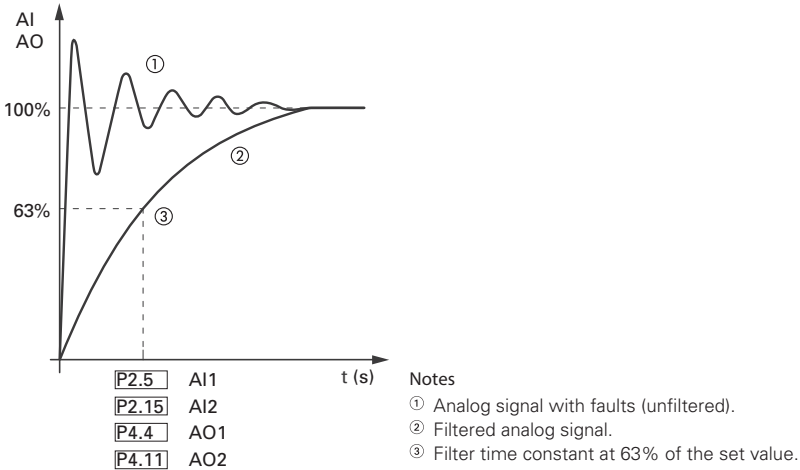

Appendix A—Description of parameters

Code	Modbus ID	Parameter	Application	RO/RW
P3.3.5	150	A01 Scale	1,2,3	RW

This parameter will scale the analog output function from 10% to 1000%, in adjusting this value it will either extend or shrink the scale on the analog signal from 0-10V/0-20mA or 2-10V/4-20mA.

Figure 54. Analog output scaling

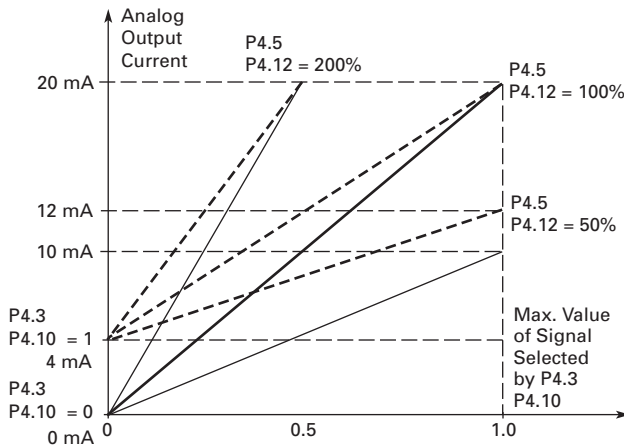

P3.3.6	148	A01 Inversion	1,2,3	RW
--------	-----	---------------	-------	----

Use this parameter to invert the analog output signal, normally 0V/0mA/2V/4mA = 0% and 10V/20mA = 100%, when inverted 0V/0mA/2V/4mA = 100% and 10V/20mA = 0%.
Maximum output signal = Minimum set value.
Minimum output signal = Maximum set value.

Figure 55. Analog output invert

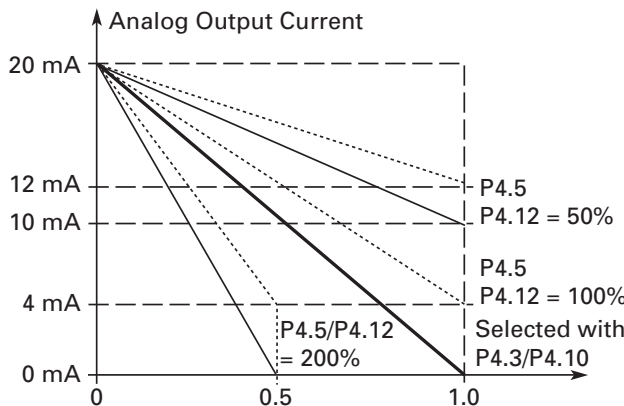

P3.3.7	173	A01 Offset	1,2,3	RW
--------	-----	------------	-------	----

This parameter is used to add a offset of -100.0 to 100.0% to the analog output minimum value to add in an additional offset scale factor.

P3.4.1	228	A02 Mode	1,2,3	RW
--------	-----	----------	-------	----

Use this parameter to select the analog output mode for A02 as current or voltage. There are internal relays to perform the switching of the signal between mA or V.

P3.4.2	229	A02 Function	1,2,3	RW
--------	-----	--------------	-------	----

Use this parameter to select the function or signal that is connected to the terminal A02 terminal 24. Scaling will vary based on the signal selected. See ID 146 for options.

P3.4.3	232	A02 Minimum	1,2,3	RW
--------	-----	-------------	-------	----

Use this parameter to define the signal minimum to be either 0 mA or 4 mA (A01 mode = 0–20 mA); 0V or 2V (A01 mode = 0–10V).
0 = Set minimum value to 0V/0 mA.
1 = Set minimum value to 2V/4 mA.

Code	Modbus ID	Parameter	Application	RO/RW
P3.4.4	230	A02 Filter Time Use this parameter to define the filtering time for the analog output signal, with a higher number the more filtering time is added on the output signal. Setting this parameter value to 0.00 will deactivate filtering.	1,2,3	RW
P3.4.5	233	A02 Scale This parameter will scale the analog output function from 10% to 1000%, in adjusting this value it will either extend or shrink the scale on the analog signal from 0-10V/0-20mA or 2-10V/4-20mA.	1,2,3	RW
P3.4.6	231	A02 Inversion Use this parameter to invert the analog output signal, normally 0V/0mA/2V/4mA = 0% and 10V/20mA = 100%, when inverted 0V/0mA/2V/4mA = 100% and 10V/20mA = 0%: Maximum output signal = Minimum set value. Minimum output signal = Maximum set value.	1,2,3	RW
P3.4.7	234	A02 Offset This parameter is used to add a offset of -100.0 to 100.0% to the analog output minimum value to add in an additional offset scale factor.	1,2,3	RW
P3.5.1	751	Logic Function Select Use this parameter to define the logical math function used with the Logic A and B input functions. The value can be And - indicating both being active then enable the logic, OR - if one or both inputs are active then it will enabled the logic, XOR - if any one of the inputs are active the logic is enabled, if both logic's are the same state it disables the logic. The result (LOG) can then be assigned to the digital outputs DO, RO1, RO2 and RO3. The type of operation is defined in parameter ID751: 0 = AND 1 = OR 2 = XOR	3	RW
P3.5.2	752	Logic Operation Input A Use this parameter to define the logic function that is assigned to the logic A input.	3	RW
P3.5.3	753	Logic Operation Input B Use this parameter to define the logic function that is assigned to the logic B input.	3	RW
P4.1.1	141	Keypad Reference Use this parameter to modify the frequency reference on the keypad.	1,2,3	RW
P4.1.2	116	Keypad Direction Use this parameter to set the rotation direction of the motor when in the keypad control place. 0 = Forward: The rotation of the motor is forward or clockwise direction . 1 = Reverse: The rotation of the motor is reversed or counter clockwise direction.	1,2,3	RW
P4.1.3	114	Keypad Stop Use this parameter to make the STOP button a "hot-spot" that always stops the drive regardless of the selected control place, set the value of this parameter to "Always Enabled". "Enable - Keypad Operation" activates the stop button only in keypad mode or the local control place.	1,2,3	RW
P4.1.4	1724	Hand Key Enable Use this parameter to enable the Hand key function tied to the Start button.	1,2,3	RW
P4.1.5	1679	Reverse Enable Use this parameter to enables or disables the reverse motor direction.	1,2,3	RW
P4.1.6	2515	Change PhaseSequence Motor Use this parameter allows for swapping the motor phase output from u, v, w to u, w, v. This does not affect the forward/reverse selection. Can be used in fan and pump applications where motor rotation was incorrect and not able to swap motor leads.	1,2,3	RW
P4.1.7	1685	Power Up HOA Select Selects the control place location on power up. By default it will hold the last state that the drive was in when power was removed. Otherwise by setting to "Local" or "Remote" it would default back to that control place when power is reapplied.	1,2,3	RW
P4.1.8	2462	Bumpless Enable Use this parameter for switching from local to remote mode, change reference only if changed in new source after switching, thus enabling use of ramps. Upon transition stopping can be performed via Keypad Stop, Enable input, ExtFault, or E-Stop.	3	RW

Appendix A—Description of parameters

Code	Modbus ID	Parameter	Application	RO/RW
P4.1.9	2423	Run Delay Time Run Delay time parameter sets the time required for the drive to wait before another run command can be received. During this time the run signal is given it is ignored until the time has expired upon which it will then start, in keypad, I/O, or fieldbus Control Modes.	1,2,3	RW
P4.1.10	252	Start Mode Use this parameter to define the start function. Ramp 0 = The frequency converter starts from 0 Hz and accelerates to the set reference frequency within the set acceleration time. (Load inertia or starting friction may cause prolonged acceleration times.) Flying start 1 = The frequency converter is able to start into a running motor by applying a small voltage to motor to search for the frequency corresponding to the speed the motor is running at. Searching starts from the maximum frequency toward the actual frequency until the correct value is detected. Thereafter, the output frequency will be increased/decreased to the set reference value according to the set acceleration/deceleration parameters. Use this mode if the motor is coasting when the start command is given, with the flying start.	1,2,3	RW
P4.1.11	253	Stop Mode Use this parameter to define the stop function. Coasting 0 = The motor coasts to a halt without any control from the frequency converter, after the Stop command, output of drive shuts off. The Motor slows based off the inertia loss. Ramp 1 = After the Stop command, the speed of the motor is decelerated according to the set deceleration parameters. If the regenerated energy is high and a faster deceleration is required, it may be necessary to use an external braking resistor for faster deceleration. Enabled Normal stop: Ramp/ Run Disable stop: coasting	1,2,3	RW
P4.1.12	247	Ramp 1 Shape Use this parameter to make the beginning and end of the acceleration and deceleration ramps can be smoother. Setting a value of 0.0 gives a linear ramp shape that causes acceleration and deceleration to react immediately to the changes in the reference signal. Setting a value from 0.1 to 10 seconds for this parameter produces an S-shaped acceleration/ deceleration at the start and stop of the slope.	1,2,3	RW
P4.1.13	248	Ramp 2 Shape The start and end of the acceleration and deceleration ramps can be smoothed with these parameters. Setting a value of 0.0 gives a linear ramp shape that causes acceleration and deceleration to react immediately to the changes in the reference signal. Setting a value from 0.1 to 10 seconds for this parameter produces an S-shaped acceleration/ deceleration at the start and stop of the slope.	1,2,3	RW

Figure 56. Acceleration/Deceleration (S-shaped)

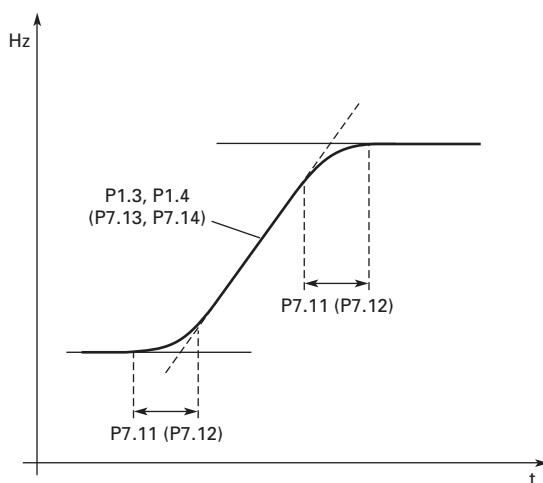

Code	Modbus ID	Parameter	Application	RO/RW
P4.1.14	249	Accel Time 2 Use this parameter to set the time required for the output frequency to accelerate from the zero frequency to the set maximum frequency. These parameters provide the possibility to set two different acceleration/deceleration time sets for one application. The active set can be selected with the programmable digital input.	1,2,3	RW
P4.1.15	250	Decel Time 2 Use this parameter to set the time required for the output frequency to accelerate from the zero frequency to the set maximum frequency. These parameters provide the possibility to set two different acceleration/deceleration time sets for one application. The active set can be selected with the programmable digital input.	1,2,3	RW
P4.1.16	267	Power Loss Function Use this parameter to enable or disable the power loss ride thru function. When enabled the drive will stop the output voltage to the motor allowing motor to coast down but PWM active to feed power back into drive to keep the drive powered up as long as it can before power is lost. The drive will accept restart and safely control the motor in the time set without cycling the run command if input voltage returns. This mode is engaged at the following levels - 230V - 156.8Vdc, 480V - 303Vdc, and 575 - 426.65Vdc. 1 = Enable power loss function 0 = Disable power loss function	1,2,3	RW
P4.1.17	268	Power Loss Time Use this parameter to set the allowable power loss max time before the drive will not auto restart when power is reestablished and run command active. If AC input voltage recovers before this time expires, drive shall continue to operate.	1,2,3	RW
P4.1.18	2444	2nd Stage Ramp Frequency Use this parameter to define the frequency level where the drive enables the 2 th Stage Ramp Frequency output function. This then can be used for other inputs or devices to signal a frequency level.	1,2,3	RW
P4.2.1	254	DC-Brake Current Use this parameter to set the amount of DC current as an amp value that is injected into the motor during DC braking.	1,2,3	RW
P4.2.2	263	Start DC-Brake Time Use this parameter to set the length of time the DC-brake is activated when the start command is given.	1,2,3	RW
P4.2.3	262	Stop DC-Brake Frequency Use this parameter to set the frequency level in hz at which DC braking starts during the deceleration phase.	1,2,3	RW

Appendix A—Description of parameters

Code	Modbus ID	Parameter	Application	RO/RW
P4.2.4	255	Stop DC-Brake Time	1,2,3	RW

Use this parameter to set the length of DC braking at stop.
 0.0 = DC-brake is not used
 >0.0 = DC-brake is in use and its function depends on the Stop function. The DC-braking time is determined with this parameter.
 Para ID 253 = 1; Stop function = Ramp:
 After the stop command, the motor coasts to a stop without control of the frequency converter.
 With DC-injection, the motor can be electrically stopped in the shortest possible time, without using an optional external braking resistor.
 The braking time is scaled according to the frequency when the DC-braking starts. If the frequency is \geq the nominal frequency of the motor, the set value of parameter ID 255 determines the braking time.
 When the frequency is $\leq 10\%$ of the nominal, the braking time is 10% of the set value of Para ID 255.
 Para ID 253 = 1; Stop function = Ramp:
 After the Stop command, the speed of the motor is reduced according to the set deceleration parameters, as fast as possible, to the speed defined with Para ID 262, where the DC-braking starts.
 The braking time is defined with Para ID 262. If high inertia exists, it is recommended to use an external braking resistor for faster deceleration.

Figure 57. DC-Braking time when stop mode = coasting

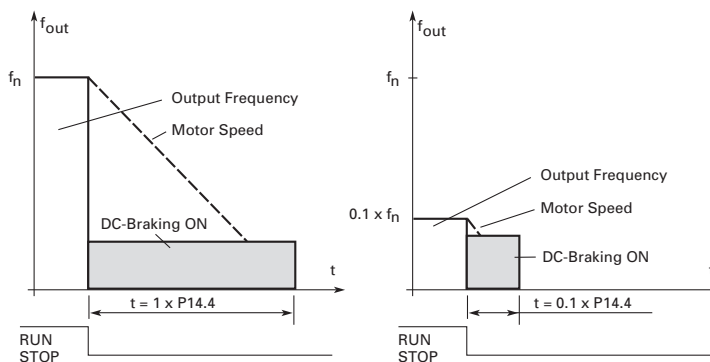
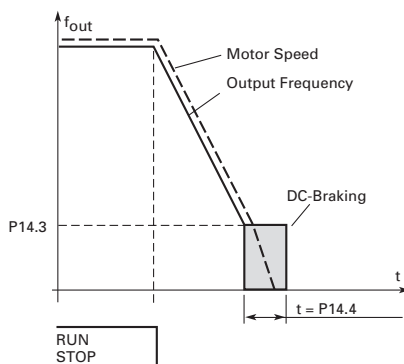

Figure 58. DC-Braking time when stop mode = ramp



P4.2.5	251	Brake Chopper Define	1,2,3	RW
--------	-----	-----------------------------	-------	----

Use this parameter to enable/disable the internal brake chopper logic if a brake chopper is installed.
 When the frequency converter is decelerating the motor, the inertia of the motor and the load is fed into an external brake resistor. This enables the frequency converter to decelerate the load with a torque equal to that of acceleration (provided that the correct brake resistor has been selected).
 0 = No brake chopper used
 1 = Brake chopper in use and tested when running. Can be tested also in READY state.
 2 = External brake chopper (no testing)
 3 = Used and tested in READY state and when running
 4 = Used when running (no testing)

Code	Modbus ID	Parameter	Application	RO/RW
P4.2.6	266	Flux Brake Use this parameter to enable the flux braking, the frequency is reduced and the flux in the motor is increased, which in turn increases the motor's capability to brake. Unlike DC braking, the motor speed remains controlled during braking. The flux braking can be set ON or OFF. 0 = Flux braking OFF 1 = Flux braking ON Note: Flux braking converts the energy into heat in the motor, and should be used intermittently to avoid motor damage.	1,2,3	RW
P4.2.7	265	Flux Brake Current Use this parameter to set the level of current In amps for the flux braking is enabled.	1,2,3	RW
P4.3.1	264	Skip Range Ramp Factor Use this parameter to set the multiplier used for acceleration/deceleration time when the output frequency is between the selected prohibit frequency range limits. The ramping speed (selected acceleration/deceleration time 1 or 2) is multiplied with this factor. e.g., value 0.1 makes the acceleration time 10 times shorter than outside the prohibit frequency range limits.	1,2,3	RW
P4.3.2	256	Skip F1 Low Limit Use this parameter to set frequency limits to prevent the drive from operating in, the frequency converter will skip the set frequencies, ramp time will be the same. In some systems it may be necessary to avoid certain frequencies because of mechanical resonance problems.	1,2,3	RW
P4.3.3	257	Skip F1 High Limit Use this parameter to set frequency limits to prevent the drive from operating in, the frequency converter will skip the set frequencies, ramp time will be the same. In some systems it may be necessary to avoid certain frequencies because of mechanical resonance problems.	1,2,3	RW
P4.3.4	258	Skip F2 Low Limit Use this parameter to set frequency limits to prevent the drive from operating in, the frequency converter will skip the set frequencies, ramp time will be the same. In some systems it may be necessary to avoid certain frequencies because of mechanical resonance problems.	1,2,3	RW
P4.3.5	259	Skip F2 High Limit Use this parameter to set frequency limits to prevent the drive from operating in, the frequency converter will skip the set frequencies, ramp time will be the same. In some systems it may be necessary to avoid certain frequencies because of mechanical resonance problems.	1,2,3	RW
P4.3.6	260	Skip F3 Low Limit Use this parameter to set frequency limits to prevent the drive from operating in, the frequency converter will skip the set frequencies, ramp time will be the same. In some systems it may be necessary to avoid certain frequencies because of mechanical resonance problems.	1,2,3	RW

Appendix A—Description of parameters

Code	Modbus ID	Parameter	Application	RO/RW
P4.3.7	261	Skip F3 High Limit	1,2,3	RW

Use this parameter to set frequency limits to prevent the drive from operating in, the frequency converter will skip the set frequencies, ramp time will be the same. In some systems it may be necessary to avoid certain frequencies because of mechanical resonance problems.

Figure 59. Example of skip frequency area setting

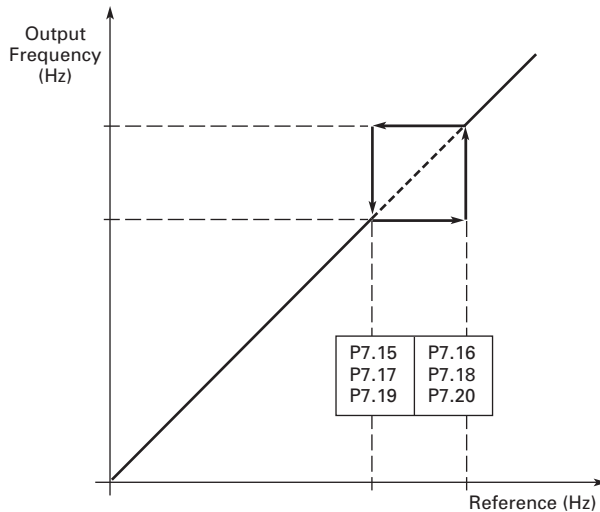

P4.4.1	2122	Currency	1,2,3	RW
--------	------	-----------------	-------	----

Use this parameter to set the local currency value for where the drive is located so it can perform the Energy Savings estimation in terms of currency saved.

- 0 = \$
- 1 = GBP
- 2 = Eur
- 3 = JPY
- 4 = Rs
- 5 = R\$
- 6 = Fr
- 7 = Kr

P4.4.2	2123	Energy Cost	1,2,3	RW
--------	------	--------------------	-------	----

Use this parameter to set the local energy cost per kW, with this value the drive will use it in the energy savings calculation.

P4.4.3	2124	Data Type	1,2,3	RW
--------	------	------------------	-------	----

Use this parameter to select the format to view Energy Savings in. The drive takes four recordings in an hour and then calculates the average based off this setting. The savings is compared to what it would cost to run across the line starter in the same load.

- 0 = Cumulative
- 1 = Daily Avg
- 2 = Weekly Avg
- 3 = Monthly Avg
- 4 = Yearly Avg

P4.4.4	2125	Energy Savings Reset	1,2,3	RW
--------	------	-----------------------------	-------	----

Use this parameter to reset the Energy Savings calculation value.

P5.1.1	287	Motor Control Mode	1,2,3	RW
--------	-----	---------------------------	-------	----

Use this parameter to set the drive control mode.

0 = Frequency control: Motor is controlled by giving a frequency reference to it. Voltage reference is calculated from scalar U/f ratio according to preprogrammed curve. (Output frequency resolution = 0.01 Hz). The frequency reference can be from I/O terminal, keypad or communication bus.

1 = Speed control: Motor is controlled by giving a frequency reference to it with slip compensation.

Voltage reference is calculated from scalar U/f ratio according to preprogrammed curve. (Output frequency resolution = 0.01 Hz). The speed reference can be from I/O terminal, keypad or communication bus (accuracy $\pm 0.5\%$).

Code	Modbus ID	Parameter	Application	RO/RW
P5.1.2	107	Current Limit This parameter determines the maximum motor current allowed from the frequency converter. When the motor current hits this level it goes into the current controller and tries to limit the output frequency to drop the current. This is not a fault trip limit.	1,2,3	RW
P5.1.3	109	V/Hz Optimization Use this parameter to enable an increase in voltage to the motor change automatically, this allows the motor to produce sufficient torque to start and run at low frequencies because of high starting torque processes. The voltage increase depends on the motor type and power. When enabled this has an effect on the linear V/hz curve. Best results can be obtained from doing a motor identification and run the programmable V/hz curve. Example: What changes are required to start the load from 0 Hz? First set the motor nominal values (Basic Parameter group). Option 1: Activate the Automatic torque boost. Option 2: Programmable V/Hz curve. To obtain the required torque, the zero point voltage and midpoint voltage/frequency (in parameter Motor Control group) need to be set, so that the motor can draw enough current at the low frequencies. First set parameter Para ID108 to Programmable V/Hz curve (value 2). Increase the zero point voltage Para ID293 to get enough current at zero speed. Then set the midpoint voltage Para ID292 to 100% and the midpoint frequency Para ID291 to value Para ID292/100%*Para ID488. Note: In high torque—low speed applications—it is likely that the motor will overheat. If the motor has to run a prolonged time under these conditions, special attention must be paid to cooling the motor. Use external cooling for the motor if the temperature tends to rise too high.	1,2,3	RW
P5.1.4	108	V/Hz Ratio Use this parameter to set the type of V/Hz curve to use between the zero frequency and the field weakening point. Linear 0 = The voltage of the motor changes linearly with the frequency in the constant flux area from 0 Hz to the field weakening point where the nominal voltage is supplied to the motor. A linear V/Hz ratio should be used in constant torque applications. This default setting should be used if there is no special need for another setting. Squared 1 = The voltage of the motor changes following a squared curve form with the frequency in the area from 0 Hz to the field weakening point where the nominal voltage is supplied to the motor. The motor runs under magnetized below the field weakening point and produces less torque and electromechanical noise. A squared V/Hz ratio can be used in applications where the torque demand of the load is proportional to the square of the speed, e.g., in centrifugal fans and pumps. Programmable V/Hz curve	1,2,3	RW

Figure 60. Linear and squared change of motor voltage

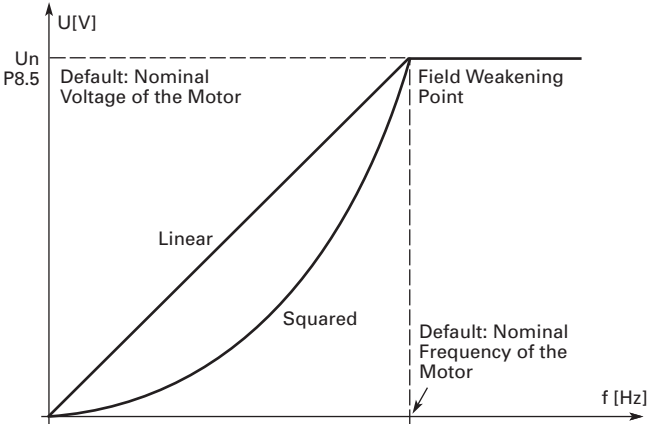

Appendix A—Description of parameters

Code	Modbus ID	Parameter	Application	RO/RW
P5.1.4	108	<p>2 = The V/Hz curve can be programmed with three different points. These points are the 0 frequency voltage, midpoint and weakening point. A programmable V/Hz curve can be used if the other settings do not satisfy the needs of the application. When running the Motor Identification this parameter gets set by default along with the values below for the V/Hz curve along with the resistance information of the motor.</p> <p>Manual Motor Tuning - in Multi-Purpose App</p> <ol style="list-style-type: none"> Setting the Motor Magnetizing current: <ul style="list-style-type: none"> Run the Motor at 2/3 of the motor nominal frequency as the frequency reference. Read the Motor current in the Monitor Menu or via the InControl PC tool. Set the current as the Motor Excitation Current(Para ID775) Set the V/Hz optimization parameter (Para ID108) to value 2 "Programmable V/Hz curve". Run the Motor with zero frequency reference and increase the motor zero point voltage (Para ID293) until the motor current is approximately same as the motor Excitation Current. If the Motor is in a low frequency area for only short periods, 65% of the motor nominal current is possible. Set the Midpoint Voltage (Para ID292) to $1.4142 * (\text{Para ID293})$ and midpoint frequency(Para ID291) to value $\text{Para ID291}/100\% * \text{Para ID488}$. If required, activate the speed control or V/Hz Optimization (Torque Boost). If required, activate the speed control and V/Hz Optimization (Torque Boost). <p>Linear with flux optimization</p>	1,2,3	RW

Figure 61. Programmable V/Hz curve

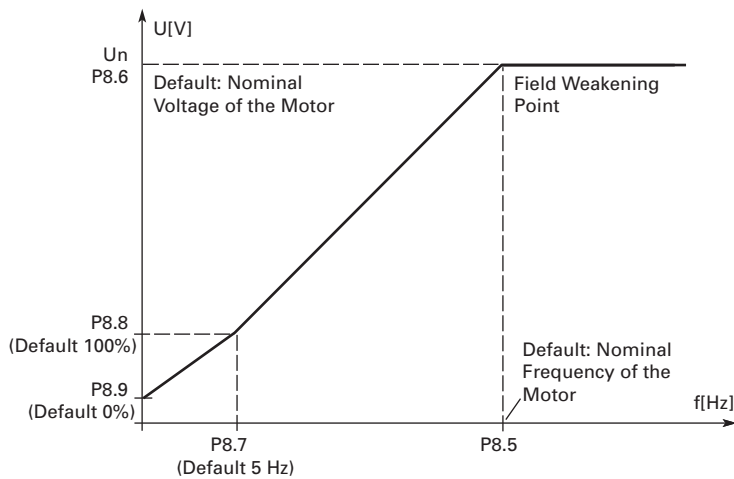

3 = The frequency converter starts to search for the minimum motor current in order to save energy, lower the disturbance level and the noise. This function can be used in applications with constant motor load, such as fans, pumps, etc.

P5.1.5	289	<p>Field Weakening Point</p> <p>Use this parameter to set the frequency at which the output voltage reaches the field weakening point. This value is usually determined by the motor nameplate value or if motor specs were supplied it can be further adjusted.</p>	1,2,3	RW
P5.1.6	290	<p>Voltage at FWP</p> <p>Use this parameter to set the voltage at the field weakening point as a percentage of the motor nominal voltage. Above the frequency at the field weakening point, the output voltage remains at the set maximum value. Below the frequency at the field weakening point, the output voltage depends on the setting of the V/Hz curve parameters.</p>	1,2,3	RW
P5.1.7	291	<p>V/Hz Mid Frequency</p> <p>Use this parameter if the programmable V/Hz curve has been selected, it defines the midpoint frequency of the curve. This value can be set anywhere between 0 and the FWP, to either have a different V/Hz ramp or if set to the FWP it will provide the max voltage all the way up the curve.</p>	1,2,3	RW
P5.1.8	292	<p>V/Hz Mid Voltage</p> <p>Use this parameter if programmable V/Hz curve has been selected, it defines the mid point voltage of the curve. This value can be set anywhere between zero frequency Volt and the FWP voltage, this can either have a different ramp above and below this point or allow for max voltage.</p>	1,2,3	RW
P5.1.9	293	<p>Zero Frequency Voltage</p> <p>Use this parameter if programmable V/Hz curve has been selected, it defines the zero frequency voltage of the curve. When putting this value above 0% additional voltage is given, in some cases by putting this value to high it can cause the motor to be oversaturated.</p>	1,2,3	RW

Code	Modbus ID	Parameter	Application	RO/RW
P5.1.10	288	Switching Frequency This parameter sets the frequency that the PWM wave rides on, higher switching frequency will be cleaner the output sine wave, lower switching frequency will be a choppy sine wave. Motor noise can be minimized using a high switching frequency but the amount of heat dissipation increases. Increasing the switching frequency reduces the capacity of the frequency converter unit. For protection against thermal overload, the switching frequency automatically is reduce in the fact that the ambient temperature is high as well as high load currents. Note: See Installation Manual for the values listed for the individual frame size switching frequency ranges. It also provides de-rating tables required for sizing.	1,2,3	RW
P5.1.11	1665	Sine Filter Enable This parameter is used when a sine filter is connected to the output motor leads, the parameter is used to lock in the thermal management controls to not decrease the Switching frequency.	1,2,3	RW
P5.1.12	294	OverVoltage Control This parameters allow the overvoltage controllers to be switched out of operation. This may be useful, for example, if the main supply voltage varies more than -15% to +10% and the application will not tolerate this overvoltage. In this case, the regulator controls the output frequency taking the supply fluctuations into account. 0 = Controller switched off 1 = Controller switched on	1,2,3	RW
P5.1.13	298	Load Drooping This parameter is used to enable speed drop as a function of the load, used to share loads between mechanically coupled motors. This parameter corresponds to the nominal torque of the motor. Example: If load drooping is set to 10% for a motor that has a nominal frequency of 50Hz and is nominally loaded (100% of torque) the output frequency is allowed to decrease 5Hz from the frequency reference. The function is used for e.g. when balanced load is needed for mechanically connected motors.	3	RW
P5.1.14	1630	Droop Control Filter Time Constant Filter time when using droop control	3	RW
P5.2.1	577	Motor Nom Current 2 Use this parameter to set the second motor set name plate Current. Selected based off of a digital input.	2,3	RW
P5.2.2	578	Motor Nom Speed 2 Use this parameter to set the second motor set name plate RPM. Selected based off of a digital input.	2,3	RW
P5.2.3	579	Motor PF 2 Use this parameter to set the second motor set name plate Power Factor. Selected based off of a digital input.	2,3	RW
P5.2.4	580	Motor Nom Volt 2 Use this parameter to set the second motor set name plate Voltage. Selected based off of a digital input.	2,3	RW
P5.2.5	581	Motor Nom Freq 2 Use this parameter to set the second motor set name plate Frequency. Selected based off of a digital input.	2,3	RW
P6.1.1	308	Output Phase Fault Use this parameter to set the device reaction to a "Phase Loss Output" condition. This failure could be device dependent. 0 = No response 1 = Warning 2 = Fault, stop mode after fault according to standard stop mode 3 = Fault, stop mode after fault always by coasting	1,2,3	RW
P6.1.2	309	Ground Fault Use this parameter to set the device reaction to a "Ground Fault U-V-W" fault condition. This failure could be device dependent. The level of fault occurs is based off the total drive current and the Para ID2158. 0 = No response 1 = Warning 2 = Fault, stop mode after fault according to standard stop mode 3 = Fault, stop mode after fault always by coasting	1,2,3	RW

Appendix A—Description of parameters

Code	Modbus ID	Parameter	Application	RO/RW
P6.1.3	2158	Ground Fault Limit This parameter sets the level of the ground fault protection, this protection is based off the amount of leakage current that is seen to ground on the output of the drive.	1,2,3	RW
P6.1.4	310	Motor Thermal Protection Use this parameter to set the device reaction to a "Overtemperature Motor" fault condition. This failure could be device dependent. Deactivating this protection, i.e., setting parameter to 0, will reset the thermal stage of the motor to 0%. 0 = No response 1 = Warning 2 = Fault, stop mode after fault according to standard stop mode 3 = Fault, stop mode after fault always by coasting	1,2,3	RW
P6.1.5	311	Motor Thermal F0 Current This parameter sets minimal current at speed zero without thermal overload. The default value is set assuming that there is no external fan cooling the motor. If an external fan is used, this parameter can be set to 90% (or even higher). Note: The value is set as a percentage of the motor nameplate data, Para ID486 (nominal current of the motor), not the drive's nominal output current. The motor's nominal current is the current that the motor can withstand in direct on-line use without being overheated. If you change the parameter Nominal current of motor, this parameter is automatically restored to the default value. Setting this parameter does not affect the maximum output current of the drive, which is determined by Param ID1679 alone.	1,2,3	RW

Figure 62. Motor thermal current it curve

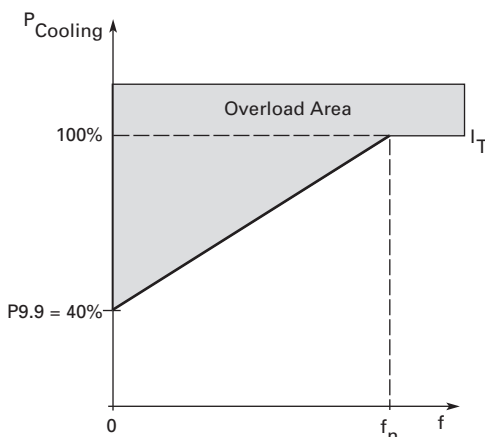

Code	Modbus ID	Parameter	Application	RO/RW
P6.1.6	312	Motor Thermal Time	1,2,3	RW

This parameter is used to set the time constant of the motor to rise to 63% of thermal load. The motor thermal time is specific to the motor design and it varies between different motor manufacturers.
 If the motor's t6-time (t6 is the time in seconds the motor can safely operate at six times the rated current) is known (given by the motor manufacturer) the time constant parameter can be set based on it. As a rule of thumb, the motor thermal time constant in minutes is equal to 2xt6. If the drive is in stop stage, the time constant is internally increased to three times the set parameter value. The cooling in the stop stage is based on convection and the time constant is increased.

Figure 63. Motor temperature calculation

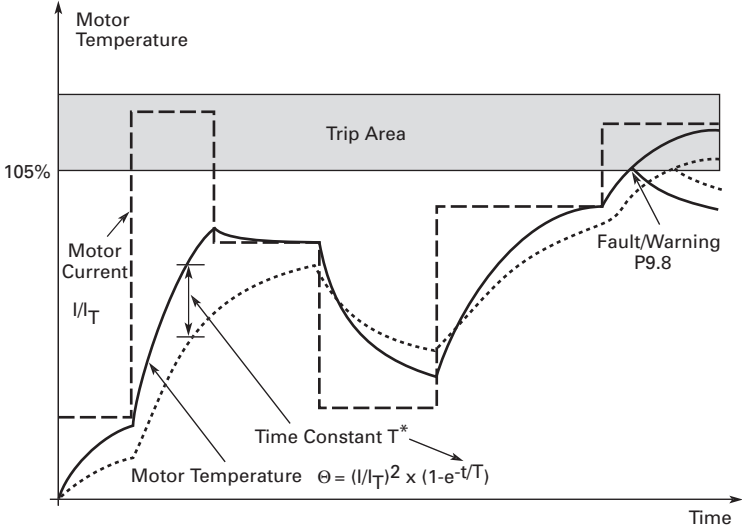

* Changes by motor size and adjusted with P9.10.

P6.1.7	313	Stall Protection	1,2,3	RW
--------	-----	-------------------------	-------	----

Use this parameter to set the device reaction after a "Motor Stalled" condition has occurred. This is customer selectable based off of current level, frequency level and time.
 0 = No Action
 1 = Warning
 2 = Fault
 3 = Fault, Coast

Appendix A—Description of parameters

Code	Modbus ID	Parameter	Application	RO/RW
P6.1.8	314	Stall Current Limit	1,2,3	RW

This parameter is used to set the current level when above the unit will stall. For a stall stage to occur, the current must have exceeded this limit. The software does not allow entering a greater value than $I_n \cdot \text{Motor} * 2$. If nominal motor current is changed, this parameter is automatically restored to the default value (IL).

Figure 64. Stall characteristics settings

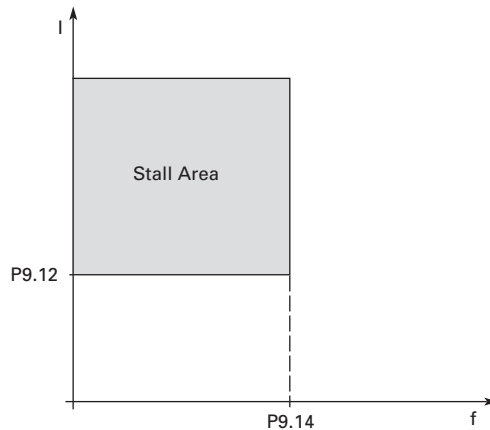

P6.1.9	315	Stall Time Limit	1,2,3	RW
--------	-----	-------------------------	-------	----

This parameter is used to set the time limit before a stall error occurs. The stall time is counted by an internal up/down counter based off the current being above the limit setting. If the stall time counter value goes above this limit the protection will cause a trip (see Para ID313).

Figure 65. Stall time count

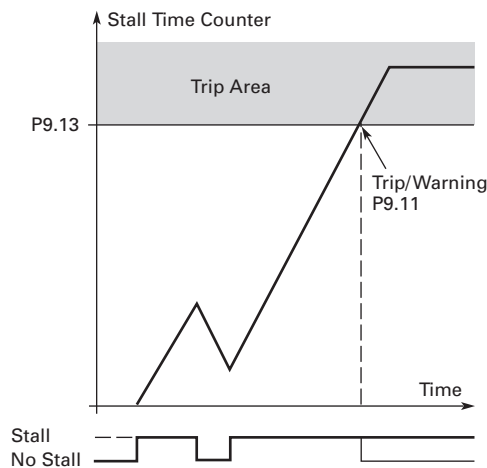

P6.1.10	316	Stall Frequency Limit	1,2,3	RW
---------	-----	------------------------------	-------	----

This parameter is used to set the frequency level where below it a stall condition and is above the current limit for the stall time to occur.

P6.1.11	317	Underload Protection	1,2,3	RW
---------	-----	-----------------------------	-------	----

This parameter is used to set the device reaction to an "UnderLoad Motor" condition. Deactivating the protection by setting the parameter to 0 will reset the underload time counter to zero.

- 0 = No response
- 1 = Warning
- 2 = Fault, stop mode after fault according to standard stop mode
- 3 = Fault, stop mode after fault always by coasting

Code	Modbus ID	Parameter	Application	RO/RW
P6.1.12	318	Underload Fnom Torque	1,2,3	RW

This parameter gives the value for the minimum torque allowed when the output frequency is at or above the field weakening point. If you change Para ID486, nominal motor current, this parameter is automatically restored to the default value.

Figure 66. Setting of minimum load

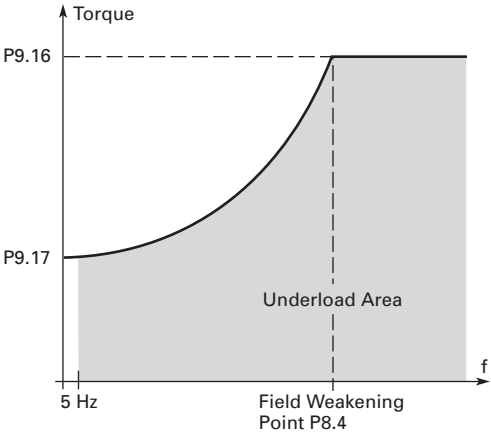

P6.1.13	319	Underload F0 Torque	1,2,3	RW
---------	-----	----------------------------	-------	----

This parameter gives value for the minimum torque allowed at zero frequency. If you change the value of Para ID486, nominal motor current, this parameter is automatically restored to the default value.

P6.1.14	320	Underload Time Limit	1,2,3	RW
---------	-----	-----------------------------	-------	----

This is the maximum time allowed in an underload condition. An internal up/down counter counts the accumulated underload time. If the underload counter value goes above this limit, the protection will cause a trip according to Para ID317. If the drive is stopped, the underload counter is reset to zero.

Figure 67. Underload time counter function

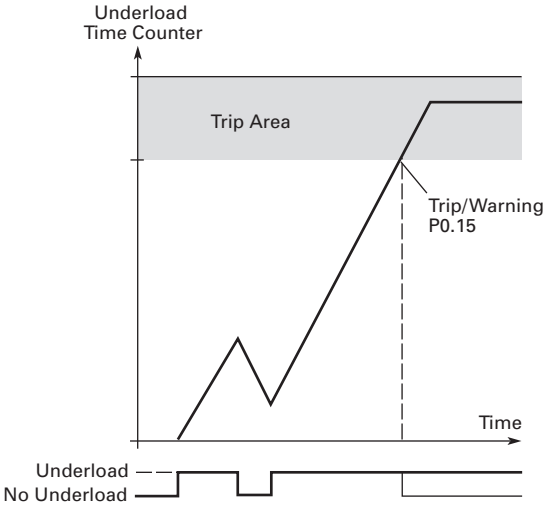

P6.1.15	333	Thermistor Fault Response	1,2,3	RW
---------	-----	----------------------------------	-------	----

This parameter is used to define the device reaction after a "Thermistor Fault Motor" condition occurs. This failure could be device dependent.
 0 = No response
 1 = Warning
 2 = Fault, stop mode after fault according to standard stop mode.
 3 = Fault, stop mode after fault always by coasting

Appendix A—Description of parameters

Code	Modbus ID	Parameter	Application	RO/RW
P6.1.16	337	PT100 Fault Response This parameter sets the device reaction after a “PT100 Fault” condition has occurred. This condition could be possible device dependent. 0 = No response 1 = Warning 2 = Fault, stop mode after fault according to standard stop mode 3 = Fault, stop mode after fault always by coasting	1,2,3	RW
P6.1.17	2159	Preheat Mode This parameter defines the location for enabling or disabling the preheat function where this is used in the case depending on where the temperature is being read from the drive will turn on the output to allow current to flow to the motor if the temperature of the drive or PT100 sensor drops, this is typically used when the motor is not running. 0 = Disable 1 = Enable	1,2,3	RW
P6.1.18	2160	Preheat Control Source This parameter selects the source of where the temperature is coming from to enable the preheat function, it can be enabled from a digital input or automatically via internal/external temperature sensors. 0 = DigIN: NormallyOpen 1 = DigIN: NormallyClosed 2 = DigIN: 1 3 = DigIN: 2 4 = DigIN: 3 5 = DigIN: 4 6 = DigIN: 5 7 = DigIN: 6 8 = DigIN: 7 9 = DigIN: 8 10 = DigIN: A: IO1: 1 11 = DigIN: A: IO1: 2 12 = DigIN: A: IO1: 3 13 = DigIN: A: IO5: 1 14 = DigIN: A: IO5: 2 15 = DigIN: A: IO5: 3 16 = DigIN: A: IO5: 4 17 = DigIN: A: IO5: 5 18 = DigIN: A: IO5: 6 19 = DigIN: B: IO1: 1 20 = DigIN: B: IO1: 2 21 = DigIN: B: IO1: 3 22 = DigIN: B: IO5: 1 23 = DigIN: B: IO5: 2 24 = DigIN: B: IO5: 3 25 = DigIN: B: IO5: 4 26 = DigIN: B: IO5: 5 27 = DigIN: B: IO5: 6 28 = Time Channel 1 29 = Time Channel 2 30 = Time Channel 3 31 = Drive Temperature 32 = SlotA PT100 Temp Channel 1 33 = Slot A PT100 Temp Channel 2 34 = SlotA PT100 Temp Channel 3 35 = SlotA Max PT100 Temp 36 = SlotB PT100 Temp Channel 1 37 = SlotB PT100 Temp Channel 2 38 = SlotB PT100 Temp Channel 3 39 = SlotB Max PT100 Temp 40 = Slot A and SlotB Max PT100 Temp	1,2,3	RW
P6.1.19	2161	Preheat Enter Temp This parameter is used to set the temperature level when the preheat is enabled if using one of the internal or external temperature mode settings in Para ID2160.	1,2,3	RW
P6.1.20	2162	Preheat Quit Temp This parameter is used to set the temperature level when the preheat is disabled if using one of the internal or external temperature mode settings in Para ID2160.	1,2,3	RW

Code	Modbus ID	Parameter	Application	RO/RW
P6.1.21	2163	Preheat Output Volt This parameter is used to set the voltage level output to the motor when the drive is in the Preheat operation mode. This is a percentage of the motor nameplate voltage.	1,2,3	RW
P6.2.1	750	Line Start Lockout This parameter determines the response of frequency converter going to a run state cycle with I/O run command is still active as the control place. 0 = Respond to I/O run command when power is applied. If in another control place and switched to I/O control do not respond. (Run Command has to be cycled) 1 = Do not respond to I/O run command when power is applied. If in another control place and switched to I/O control do not respond (Run Command has to be cycled) 2 = Respond to I/O commands when power is applied. If in another control place and switched to I/O control the drive will respond to a maintained Run Command. 3 = Do Not respond to I/O commands when power is applied. If in another control place and switched to I/O control the drive will respond to a maintained Run Command.	1,2,3	RW
P6.2.2	2483	Fault Reset Start This parameter is used to defines how the drive would start after a Fault Reset is given if the run command is still present to the device. 0 - Start/Stop After Fault Reset - run command has to be cycled to restart after fault reset. 1 - Restart After Fault Reset - run command is still active after fault the drive will restart without resending command.	1,2,3	RW
P6.2.3	306	4mA Input Fault Use this parameter to set the device reaction after occurring of “4-20mA fault”. This fault could be device dependent. The information can also be programmed into digital output DO1 or relay outputs RO1 and RO2. 0 = No response 1 = Warning 2 = Warning, the frequency from 10 seconds back is set as reference 3 = Warning, the Preset Frequency Para ID331 is set as reference 4 = Fault, stop mode after fault according to standard stop mode. 5 = Fault, stop mode after fault always by coasting	1,2,3	RW
P6.2.4	331	4mA Fault Frequency Use this parameter to set the preset frequency for the 4-20mA fault condition. See Para ID306 = 3.	1,2,3	RW
P6.2.5	307	External Fault Use this parameter to set the device reaction after occurring of “External Fault”. This failure could be device dependent. The status information can also be programmed into digital output DO1 and into relay outputs RO1 and RO2. 0 = No response 1 = Warning 2 = Fault, stop mode after fault according to standard stop mode 3 = Fault, stop mode after fault always by coasting	1,2,3	RW
P6.2.6	332	Input Phase Fault Use this parameter to set the device reaction to a “Phase Loss” fault condition. This failure could be device dependent. 0 = No response 1 = Warning 2 = Fault, stop mode after fault according to standard stop mode 3 = Fault, stop mode after fault always by coasting	1,2,3	RW
P6.2.7	330	Uvoltage Fault Response Use this parameter to set the device reaction to a “UnderVoltage Mains” fault condition. This failure could be device dependent. 0 = No response 1 = Warning 2 = Fault, stop mode after fault according to standard stop mode 3 = Fault, stop mode after fault always by coasting	1,2,3	RW
P6.2.8	1564	Unit Under Temp Prot This parameter used to set the reaction when a “Undertemperature Device” condition occurs. This failure could be device dependent. 0 = No response 1 = Warning 2 = Fault, stop mode after fault according to standard stop mode. 3 = Fault, stop mode	1,2,3	RW

Appendix A—Description of parameters

Code	Modbus ID	Parameter	Application	RO/RW
P6.2.9	955	RTC Fault This parameter sets the device reaction after a “Realtime Clock Fault” condition has occurred. This condition could be possible device dependent. 0 = No response 1 = Warning 2 = Fault, stop mode after fault according to standard stop mode 3 = Fault, stop mode after fault always by coasting	1,2,3	RW
P6.2.10	1256	Replace Battery Fault Response This parameter sets the device reaction after a “Replace Battery” condition has occurred, when the battery falls below 2V level. This condition could be possible device dependent. 0 = No response 1 = Warning 2 = Fault, stop mode after fault according to standard stop mode 3 = Fault, stop mode after fault always by coasting	1,2,3	RW
P6.2.11	1257	Replace Fan Fault Response This parameter sets the device reaction after a “Replace Device Fan” condition has occurred, when the fan run time counter expires. This condition could be possible device dependent. 0 = No response 1 = Warning 2 = Fault, stop mode after fault according to standard stop mode 3 = Fault, stop mode after fault always by coasting	1,2,3	RW
P6.2.12	2126	Cold Weather Mode This parameter allows for enabling a cold weather function that allows the frequency converter’s under temp limit to drop from –10°C to –30°C drive. This then enables a warmup feature when the frequency converter is between –30°C and –20°C. The motor, when given a run command, will turn on for the Cold Weather Timeout (See Par ID 2128) and output the Cold Weather Voltage (See Par ID 2127) at 0.5 Hz to allow the motor to warm up. If it does not warm up above –20°C, after that the time frequency converter will fault on Under temp fault. If the frequency converter does go above –20°C, output will begin to follow reference. 0 = Disable 1 = Enable	1,2,3	RW
P6.2.13	2127	Cold Weather Volt. Level This parameter allows for setting the % of the motor voltage that is output to the motor when in the cold weather warmup period.	1,2,3	RW
P6.2.14	2128	Cold Weather Time Out This parameter allows for selecting the time limit that the frequency converter will run in the warm up period.	1,2,3	RW
P6.2.15	2129	Cold Weather Password This password allows access to override the under temperature fault protection, this parameter is seen by pressing the left and right soft keys on the keypad. Password should be set to 32866, this value gets reset on cycle of power.	1,2,3	RW
P6.2.16	2130	Under Temp Fault Override With the password set to the correct value this parameter is enabled and will give the ability to override the under temp fault. This function gets reset when power is cycled.	1,2,3	RW
P6.2.17	2427	STO Fault Response This parameter is used to set the reaction of the device after a “Safe Torque Off” condition is seen. This condition could be possible device dependent. No Action = Drive will stop no indication shown, n reset required, have to cycle start command. Fault = drive will indicate fault/Require Reset to start again, Warning = drive indicate warning/if STO clears drive will run without Reset.	1,2,3	RW
P6.3.1	334	Fieldbus Fault Response This parameter used to set the reaction after a “Network COM Fault” condition occurs. This failure could be device dependent. 0 = No response 1 = Warning 2 = Fault, stop mode after fault according to standard stop mode 3 = Fault, stop mode after fault always by coasting	1,2,3	RW

Code	Modbus ID	Parameter	Application	RO/RW
P6.3.2	335	OPTCard Fault Response This parameter used to set the reaction after a “Link to Option Card” condition occurs. This failure could be device dependent. 0 = No response 1 = Warning 2 = Fault, stop mode after fault according to standard stop mode. 3 = Fault, stop mode after fault always by coasting	1,2,3	RW
P6.3.3	1678	IP Address Conflict Resp This parameter sets the device reaction after a “IP Conflict” condition has occurred, when the ip address is duplicated on the network. This condition could be possible device dependent. 0 = No response 1 = Warning 2 = Fault, stop mode after fault according to standard stop mode 3 = Fault, stop mode after fault always by coasting	1,2,3	RW
P6.3.4	2157	Keypad Comm Fault Response This parameter determines the device reaction after a “Keypad Fault” condition. This condition could be possible device dependent. 0 = No Action 1 = Warning 2 = Fault, stop mode after fault according to standard stop mode 3 = Fault, stop mode after fault always by coasting	1,2,3	RW
P6.4.1	321	AR Wait Time This parameter defines the time before the frequency converter tries to automatically restart the motor after a specific fault condition has been received. Auto Restart faults listed Para ID324 to Para ID336.	1,2,3	RW
P6.4.2	322	AR Trail Time This parameter sets the amount of time after the Wait time that the drive uses the restart tries to attempt to restart the fault, after this time has run out without resetting the alarm drive will fault. Para ID324 to Para ID336 determine the maximum number of automatic restarts during the trial time set by Para ID322. The time count starts from the first auto restart. If the number of faults occurring during the trial time exceeds the values of Para ID324 to Para ID336 the fault state becomes active. Otherwise the fault is cleared after the trial time has elapsed and the next fault starts the trial time count again. If a single fault remains during the trial time, a fault state is true.	1,2,3	RW
<p>Figure 68. Auto restart fail (try number >2.)</p> <p>Fig5. Auto restart fail (try number >2.)</p>				
P6.4.3	323	AR Start Function This parameter defines the way the device handles the start operation after a fault occurs. The parameter defines the start mode upon a auto restart condition: 0 = Start with ramp 1 = Flying start 2 = Start according to the standard start mode	1,2,3	RW
P6.4.4	324	Undervoltage Attempts This parameter determines the number of allowed restart-attempts after “DC-Undervotlag” condition has occurred. 0 = No automatic restart >0 = Number of automatic restarts after under voltage fault. The fault is reset and the drive is started automatically after the DC-link voltage has returned to the normal level.	1,2,3	RW

Appendix A—Description of parameters

Code	Modbus ID	Parameter	Application	RO/RW
P6.4.5	325	OverVoltage Attempts This parameter determines the number of allowed restart-attempts after “DC-Overvoltage” condition has occurred. 0 = No automatic restart after overvoltage fault trip >0 = Number of automatic restarts after overvoltage fault trip. The fault is reset and the drive is started automatically after the DC-link voltage has returned to the normal level.	1,2,3	RW
P6.4.6	326	OverCurrent Attempts This parameter determines the number of allowed restart-attempts after “Overcurrent” condition has occurred. Note: An IGBT temperature fault, Saturation Fault and Overcurrent Faults are included as part of this fault. 0 = No automatic restart after overcurrent fault trip >0 = Number of automatic restarts after an overcurrent trip, saturation trip or IGBT temperature fault.	1,2,3	RW
P6.4.7	327	4mA Fault Attempts This parameter determines the number of allowed restart-attempts after “4-20mA fault” condition has occurred. 0 = No automatic restart after reference fault trip >0 = Number of automatic restarts after the analog current signal (4–20 mA) has returned to the normal level (>4 mA)	1,2,3	RW
P6.4.8	329	Motor Temp Fault Attempts This parameter determines the number of allowed restart-attempts after “Thermistorfault Motor” condition has occurred. 0 = No automatic restart after Motor temperature fault trip >0 = Number of automatic restarts after the motor temperature has returned to its normal level	1,2,3	RW
P6.4.9	328	External Fault Attempts This parameter determines the number of allowed restart-attempts after “External Fault” condition has occurred. 0 = No automatic restart after External fault trip >0 = Number of automatic restarts after External fault trip	1,2,3	RW
P6.4.10	336	Underload Attempts This parameter determines the number of allowed restart-attempts after “Underload Motor” condition has occurred. 0 = No automatic restart after an Underload fault trip >0 = Number of automatic restarts after an Underload fault trip	1,2,3	RW
P7.1.1	1294	PID1 Control Gain This parameter is used to defines the proportional gain of the PID Controller. It adjust the slope of the speed increase according to the initial of the load. If this value is set to 100% a change of 10% in the error value causes the controller output to change 10%.	2,3	RW
P7.1.2	1295	PID1 Control ITime This parameter is used to defines the integration time constant of the PID Controller. Over the time the integral time contributes to the deviation between the reference and the feedback signal. If this value is set to 1.00 sec, a change of 10% in the error value causes the controller output to change by 10.00%/s. With value set to 0.0, frequency converter operates as PD controller.	2,3	RW
P7.1.3	1296	PID1 Control DTime This parameter is used to defines the derivation time constant of the PID Controller. This value will adjust the rate of change on the feedback signal. If this value is set to 1.00 sec, a change of %10 in error value during 1.00 sec causes the control output to change by %10.00. If value is set to 0.0, frequency converter operates as PI controller.	2,3	RW
P7.1.4	1297	PID1 Process Unit This parameter is used to defines the unit type for PID controller. This will change the Feedback and Setpoint variables to show the desired unit of measure.	2,3	RW
P7.1.5	1298	PID1 Process Unit Min This parameter is used to defines the minimum process unit value for the PID controller.	2,3	RW
P7.1.6	1300	PID1 Process Unit Max This parameter is used to defines the maximum process unit value for the PID controller.	2,3	RW

Code	Modbus ID	Parameter	Application	RO/RW
P7.1.7	1302	PID1 Process Unit Decimal This parameter is used to defines the amount of decimal places used in the value for the PID Controller setpoint.	2,3	RW
P7.1.8	1303	PID1 Error Inversion This parameter defines the way the process value output reacts to the feedback signal. 0 = Normal, If feedback is less than set-point, PID controller output increases. 1 = Inverted, If feedback is less than set-point, PID controller output decreases.	2,3	RW
P7.1.9	1304	PID1 Dead Band This parameter sets the PID Dead band around the set point in process units. This is a band where no actions occur to the ouput of the PID controller, to prevent oscillation or repeated activation/deactivation of controller.	2,3	RW
P7.1.10	1306	PID1 Dead Band Delay This parameter sets the delay time, if the PID process value goes out of the Dead Band area for the desired time delay at that point the controller will re-initialize and try to level out again.	2,3	RW
P7.1.11	1311	PID1 Ramp Time This parameter defines the rising and falling ramp times for changes in the process value setpoint. The ramp time corresponds to the time it takes to change the setpoint vlaue from minimum to the maximum, if the value is 0 no ramps are used.	2,3	RW
P7.2.1	2542	FB PID1 Set Point 1 PID Set point value from Network. Can be assigned to PID Set Point Source	2,3	RW
P7.2.2	2544	FB PID1 Set Point 2 PID Set point value from Network. Can be assigned to PID Set Point Source	2,3	RW
P7.2.3	2550	FB PID1 Feedback 1 PID Feedback value from Network. Can be assigned to PID Feedback Source	2,3	RW
P7.2.4	2551	FB PID1 Feedback 2 PID Feedback value from Network. Can be assigned to PID Feedback Source	2,3	RW
P7.2.5	2554	FB PID1 Feedforward 1 PID Feedforward value from Network. Can be assigned to PID Feedforward Source	2,3	RW
P7.2.6	2555	FB PID1 Feedforward 2 PID Feedforward value from Network. Can be assigned to PID Feedforward Source	2,3	RW
P7.3.1.1	1307	PID1 Keypad Set Point 1 This parameter sets the Keypad PID Reference value set point 1.	2,3	RW
P7.3.1.2	1309	PID1 Keypad Set Point 2 This parameter sets the Keypad PID Reference value set point 2.	2,3	RW
P7.3.1.3	2466	PID1 Wake Up Action Use this parameter to define the wakeup function action. This defines if a static absolute value is used above or below the level setting or a relative value that changes based off the set point value. 0 - Wakeup when below wakeup level (Absolute Level) 1 - Wakeup when above wakeup level (Absolute Level) 2 - Wakeup when below wakeup level % from PID set point (Relative setpoint) 3 - Wakeup when above wakeup level % from PID set point (Relative setpoint)	2,3	RW
P7.3.2.1	1312	PID1 Set Point 1 Source Use this parameter to define the source of the PID set point value. This can either be an internal preset value, keypad set point, analog signal or Fieldbus message.	2,3	RW
P7.3.2.2	1313	PID1 Set Point 1 Min Use this parameter to set the minimum value for the set point 1 source.	2,3	RW
P7.3.2.3	1314	PID1 Set Point 1 Max Use this parameter to set the maximum value for the set point 1 source.	2,3	RW

Appendix A—Description of parameters

Code	Modbus ID	Parameter	Application	RO/RW
P7.3.2.4	1315	PID1 Set Point 1 Sleep Enable Use this parameter to enable PID Set Point Sleep mode function. When enabled this function will disable the output when the frequency drops below the sleep frequency for the sleep delay time. The output re engages when feedback rises above the wakeup level. When the function is disabled the drive will run at the minimum or maximum defined speed.	2,3	RW
P7.3.2.5	2396	PID1 Set Point 1 Sleep Unit Sel Use this paramter to define the variable used when going into the sleep mode. 0 = Output Frequency 1 = Motor Speed 2 = Motor Current 3 = PID1 Feedback	2,3	RW
P7.3.2.6	2450	PID1 Set Point 1 Sleep Level Use this parameter to seet the level of which the unit value is used to look at to go into the sleep mode. When the unit drops below or goes above this level for the sleep delay time it will put the drive into the sleep mode.	2,3	RW
P7.3.2.7	1317	PID1 Set Point 1 Sleep Delay Use this parameter sets the minimum time after the variable drops below the Sleep level for this amount of time that the output will shutoff.	2,3	RW
P7.3.2.8	1318	PID1 Set Point 1 Wake Up Level Use this paramter to set the level for the drive wakes up form the sleep mode condition. This level is variable based off the wake up action selection.	2,3	RW
P7.3.2.9	1320	PID1 Set Point 1 Boost Use this parameter to set the value the set point can be boosted when going into sleep mode. This is an addative variable that will add to the setpoint before drive output goes to sleep to prevent premature cycling.	2,3	RW
P7.3.2.10	1352	PID1 Set Point 1 Comp Enable Use this parameter to enables pressure loss compensation for set point 1 signal value. This is used in pump systems to compensate the pressure loss that occurs at the end of the pipe line due to the liquid flow.	2,3	RW
P7.3.2.11	1353	PID1 Set Point 1 Comp Max Use this paramter to set the maximum compensation for the PID setpoint value that is applied to the output frequency of the drive is at its maximum frequency level. This value is added to the actual setpoint value as a function of the output frequency. Set Point Compensation = comp max * (output freq–min freq)/(max freq–min freq).	2,3	RW
P7.3.3.1	1321	PID1 Set Point 2 Source Use this parameter to define the source of the PID set point value. This can either be an internal preset value, keypad set point, analog signal or Fieldbus message.	2,3	RW
P7.3.3.2	1322	PID1 Set Point 2 Min Use this parmaeter to set the minimum value for the set point 2 source.	2,3	RW
P7.3.3.3	1323	PID1 Set Point 2 Max Use this parameter to set the maximum value for the set point 2 source.	2,3	RW
P7.3.3.4	1324	PID1 Set Point 2 Sleep Enable Use this parameter to enable PID Set Point Sleep mode function. When enabled this function will disable the output when the frequency drops below the sleep frequency for the sleep delay time. The output re engages when feedback rises above the wakeup level. When the function is disabled the drive will run at the minimum or maximum defined speed.	2,3	RW
P7.3.3.5	2397	PID1 Set Point 2 Sleep Unit Sel Use this paramter to define the variable used when going into the sleep mode. 0 = Output Frequency 1 = Motor Speed 2 = Motor Current 3 = PID1 Feedback	2,3	RW
P7.3.3.6	2452	PID1 Set Point 2 Sleep Level Use this parameter to set the level of which the unit value is used to look at to go into the sleep mode. When the unit drops below or goes above this level for the sleep delay time it will put the drive into the sleep mode.	2,3	RW

Code	Modbus ID	Parameter	Application	RO/RW
P7.3.3.7	1326	PID1 Set Point 2 Sleep Delay Use this parameter sets the minimum time after the variable drops below the Sleep level for this amount of time that the output will shutoff.	2,3	RW
P7.3.3.8	1327	PID1 Set Point 2 Wake Up Level Use this paramter to set the level for the drive wakes up form the sleep mode condition. This level is variable based off the wake up action selection.	2,3	RW
P7.3.3.9	1329	PID1 Set Point 2 Boost Use this parameter to set the value the set point can be boosted when going into sleep mode. This is an addative variable that will add to the setpoint before drive output goes to sleep to prevent premature cycling.	2,3	RW
P7.3.3.10	1354	PID1 Set Point 2 Comp Enable Use this parameter to enables pressure loss compensation for set point 2 signal value. This is used in pump systems to compensate the pressure loss that occurs at the end of the pipe line due to the liquid flow.	2,3	RW
P7.3.3.11	1355	PID1 Set Point 2 Comp Max Use this paramter to set the maximum compensation for the PID setpoint value that is applied to the output frequency of the drive is at its maximum frequency level. This value is added to the actual setpoint value as a function of the output frequency. Set Point Compensation = comp max * (output freq–min freq)/(max freq–min freq).	2,3	RW

Procedure for setting up PID Application:

Initially set PID Gain(Para ID1294) to 0.0% and set the PID I Time (Para ID1295) to 20 sec. Start the frequency converter and verify if the set point is reached quickly while maintaining stable operation of the system. If not increase the PID Gain (Para ID1294) until the drive speed oscillates constantly. After this occurs reduce the PID Gain (Para ID1294) slightly to reduce the oscillation. From here take the value found for PID Gain (Para ID1294) to 0.5 times that value and reduce the PID I time (Para ID1295) until the feedback signal oscillates again. Increase the PID I time (Para ID1295) until the oscillation stops, with that value take it times 1.2 and use that value for the PID I time (Para ID1295). If signal noise is seen at high frequency increase the filter time value to filter the signal. If further tuning is required refer to the table showing what is effected.

Figure 69. Setting up PID application

Response	Rise time	Overshoot	Settling time	Steady state error
Increase PID Gain	Decrease Rise	Increases Overshoot	Not Affected	Decreases Error
Increase PID1 Time	Decrease Rise	Increases Overshoot	Increases Setting	Eliminates Error
Increase PID0 Time	Not Affected	Decreases Overshoot	Decreases Setting	Not Affected

Rise Time—the time required for the output to rise 90% of the desired level for the first time.
 Overshoot—the difference between the peak level and the steady state level. Settling Time—time required for the system to converge to its steady state.
 Steady State Error—the difference between the steady state level and the desired output level.

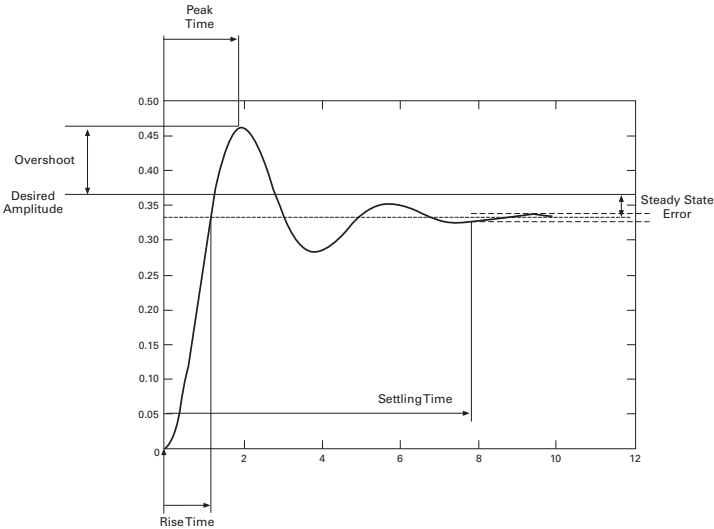

Appendix A—Description of parameters

Code	Modbus ID	Parameter	Application	RO/RW
P7.4.1.1	1330	PID1 Feedback Function Use this paramter to select if the feedback value is taken form a single signal or a combination of two signals. The mathematical functions can be selected that is used when two feedback signals are combined.	2,3	RW
P7.4.1.2	1331	PID1 Feedback Gain Use this parameter to set the gain associated with feedback signal from the measuring signals defined in the feedback function.	2,3	RW
P7.4.2.1	1332	PID1 Feedback 1 Source Use this paramter is used to select where feedback signal is being fed into the drive. This signal could be defined as analog inputs or fieldbus data value.	2,3	RW
P7.4.2.2	1333	PID1 Feedback 1 Min Use this parameter to set the minimum unit value for the feedback signal.	2,3	RW
P7.4.2.3	1334	PID1 Feedback 1 Max Use this parameter to set the maximum unit value for the feedback signal.	2,3	RW
P7.4.3.1	1335	PID1 Feedback 2 Source Use this paramter is used to select where feedback signal is being fed into the drive. This signal could be defined as analog inputs or fieldbus data value.	2,3	RW
P7.4.3.2	1336	PID1 Feedback 2 Min Use this parameter to set the minimum unit value for the feedback signal.	2,3	RW
P7.4.3.3	1337	PID1 Feedback 2 Max Use this parameter to set the maximum unit value for the feedback signal.	2,3	RW
P7.5.1.1	1338	PID1 Feedforward Func Use this paramter to select if the feedforward value is taken form a single signal or a combination of two signals. The mathamatical functions can be selected that is used when two feedback signals are combined.	2,3	RW
P7.5.1.2	1339	PID1 Feedforward Gain Use this parameter to set the gain associated with feedforward signal from the measuring signals defined in the feedback function.	2,3	RW
P7.5.2.1	1340	PID1 Feedforward 1 Source Use this parameter is used to select where feedforward signal is being fed into the drive. This signal could be defined as analog inputs or fieldbus data value.	2,3	RW
P7.5.2.2	1341	PID1 Feedforward 1 Min Use this parameter to set the minimum unit value for the feedforward signal.	2,3	RW
P7.5.2.3	1342	PID1 Feedforward 1 Max Use this parameter to set the maximum unit value for the feedforward signal.	2,3	RW
P7.5.3.1	1343	PID1 Feedforward 2 Source Use this parameter is used to select where feedforward signal is being fed into the drive. This signal could be defined as analog inputs or fieldbus data value.	2,3	RW
P7.5.3.2	1344	PID1 Feedforward 2 Min Use this parameter to set the minimum unit value for the feedforward signal.	2,3	RW
P7.5.3.3	1345	PID1 Feedforward 2 Max Use this parameter to set the maximum unit value for the feedforward signal.	2,3	RW
P8.1.1	1356	PID2 Control Gain This parameter is used to defines the proportional gain of the PID Controller. It adjust the slope of the speed increase according to the initial of the load. If this value is set to 100% a change of 10% in the error value causes the controller output to change 10%.	2,3	RW

Code	Modbus ID	Parameter	Application	RO/RW
P8.1.2	1357	PID2 Control I Time This parameter is used to defines the integration time constant of the PID Controller. Over the time the integral time contributes to the deviation between the reference and the feedback signal. If this value is set to 1.00 sec, a change of 10% in the error value causes the controller output to change by 10.00%/s. With value set to 0.0, frequency converter operates as PD controller.	2,3	RW
P8.1.3	1358	PID2 Control D Time This parameter is used to defines the derivation time constant of the PID Controller. This value will adjust the rate of change on the feedback signal. If this value is set to 1.00 sec, a change of %10 in error value during 1.00 sec causes the control output to change by %10.00. If value is set to 0.0, frequency converter operates as PI controller	2,3	RW
P8.1.4	1359	PID2 Process Unit This parameter is used to defines the unit type for PID controller. This will change the Feedback and Setpoint variables to show the desired unit of measure.	2,3	RW
P8.1.5	1360	PID2 Process Unit Min This parameter is used to defines the minimum process unit value for the PID controller.	2,3	RW
P8.1.6	1362	PID2 Process Unit Max This parameter is used to defines the maximum process unit value for the PID controller.	2,3	RW
P8.1.7	1364	PID2 Process Unit Decimal This parameter is used to defines the amount of decimal places used in the value for the PID Controller setpoint.	2,3	RW
P8.1.8	1365	PID2 Error Inversion This parameter defines the way the process value output reacts to the feedback signal. 0 = Normal, If feedback is less than set-point, PID controller output increases. 1 = Inverted, If feedback is less than set-point, PID controller output decreases.	2,3	RW
P8.1.9	1366	PID2 Dead Band This parameter sets the PID Dead band around the set point in process units. This is a band where no actions occur to the ouput of the PID controller, to prevent oscillation or repeated activation/deactivation of controller.	2,3	RW
P8.1.10	1368	PID2 Dead Band Delay This parameter sets the delay time, if the PID process value goes out of the Dead Band area for the desired time delay at that point the controller will re-initialize and try to level out again.	2,3	RW
P8.1.11	1373	PID2 Ramp Time This parameter defines the rising and falling ramp times for changes in the process value setpoint. The ramp time corresponds to the time it takes to change the setpoint vlaue from minimum to the maximum, if the value is 0 no ramps are used.	2,3	RW
P8.2.1	2467	PID2 Wake Up Action Use this parameter to define the wakeup function action. This defines if a static absolute value is used above or below the level setting or a relative value that changes based off the set point value. 0 - Wakeup when below wakeup level (Absolute Level) 1 - Wakeup when above wakeup level (Absolute Level) 2 - Wakeup when below wakeup level % from PID set point (Relative setpoint) 3 - Wakeup when above wakeup level % from PID set point (Relative setpoint)	2,3	RW
P8.2.2	2546	FB PID2 Set Point 1 PID Set point value from Network. Can be assigned to PID Set Point Source	2,3	RW
P8.2.3	2548	FB PID2 Set Point 2 PID Set point value from Network. Can be assigned to PID Set Point Source	2,3	RW
P8.2.4	2552	FB PID2 Feedback 1 PID Feedback value from Network. Can be assigned to PID Feedback Source	2,3	RW
P8.2.5	2553	FB PID2 Feedback 2 PID Feedback value from Network. Can be assigned to PID Feedback Source	2,3	RW
P8.2.6	2556	FB PID2 Feedforward 1 PID Feedforward value from Network. Can be assigned to PID Feedforward Source	2,3	RW

Appendix A—Description of parameters

Code	Modbus ID	Parameter	Application	RO/RW
P8.2.7	2557	FB PID2 Feedforward 2 PID Feedforward value from Network. Can be assigned to PID Feedforward Source	2,3	RW
P8.3.1.1	1369	PID2 Keypad Set Point 1 This parameter sets the Keypad PID Reference value set point 1.	2,3	RW
P8.3.1.2	1371	PID2 Keypad Set Point 2 This parameter sets the Keypad PID Reference value set point 2.	2,3	RW
P8.2.1	2467	PID2 Wake Up Action Use this parameter to define the wakeup function action. This defines if a static absolute value is used above or below the level setting or a relative value that changes based off the set point value. 0 - Wakeup when below wakeup level (Absolute Level) 1 - Wakeup when above wakeup level (Absolute Level) 2 - Wakeup when below wakeup level % from PID set point (Relative setpoint) 3 - Wakeup when above wakeup level % from PID set point (Relative setpoint)	2,3	RW
P8.3.2.1	1374	PID2 Set Point 1 Source Use this parameter to define the source of the PID set point value. This can either be an internal preset value, keypad set point, analog signal or Fieldbus message.	2,3	RW
P8.3.2.2	1375	PID2 Set Point 1 Min Use this parameter to set the minimum value for the set point 1 source.	2,3	RW
P8.3.2.3	1376	PID2 Set Point 1 Max Use this parameter to set the maximum value for the set point 1 source.	2,3	RW
P8.3.2.4	1377	PID2 Set Point 1 Sleep Enable Use this parameter to enable PID Set Point Sleep mode function. When enabled this function will disable the output when the frequency drops below the sleep frequency for the sleep delay time. The output re engages when feedback rises above the wakeup level. When the function is disabled the drive will run at the minimum or maximum defined speed.	2,3	RW
P8.3.2.5	2398	PID2 Set Point 1 Sleep Unit Sel Use this parameter to define the variable used when going into the sleep mode. 0 = Output Frequency 1 = Motor Speed 2 = Motor Current 3 = PID1 Feedback	2,3	RW
P8.3.2.6	2454	PID2 Set Point 1 Sleep Level Use this parameter to set the level of which the unit value is used to look at to go into the sleep mode. When the unit drops below or goes above this level for the sleep delay time it will put the drive into the sleep mode.	2,3	RW
P8.3.2.7	1379	PID2 Set Point 1 Sleep Delay Use this parameter sets the minimum time after the variable drops below the Sleep level for this amount of time that the output will shutoff.	2,3	RW
P8.3.2.8	1380	PID2 Set Point 1 WakeUp Level Use this parameter to set the level for the drive wakes up from the sleep mode condition. This level is variable based off the wake up action selection.	2,3	RW
P8.3.2.9	1382	PID2 Set Point 1 Boost Use this parameter to set the value the set point can be boosted when going into sleep mode. This is an additive variable that will add to the setpoint before drive output goes to sleep to prevent premature cycling.	2,3	RW
P8.3.2.10	1414	PID2 Set Point1 Comp Enable Use this parameter to enables pressure loss compensation for set point 1 signal value. This is used in pump systems to compensate the pressure loss that occurs at the end of the pipe line due to the liquid flow.	2,3	RW

Code	Modbus ID	Parameter	Application	RO/RW
P8.3.2.11	1415	PID2 Set Point1 Comp Max Use this paramter to set the maximum compensation for the PID setpoint value that is applied to the output frequency of the drive is at its maximum frequency level. This value is added to the actual setpoint value as a function of the output frequency. Set Point Compensation = comp max * (output freq–min freq)/(max freq–min freq).	2,3	RW
P8.2.2	2546	FB PID2 Set Point 1 PID Set point value from Network. Can be assigned to PID Set Point Source	2,3	RW
P8.3.3.1	1383	PID2 Set Point 2 Source Use this parameter to define the source of the PID set point value. This can either be an internal preset value, keypad set point, analog signal or Fieldbus message.	2,3	RW
P8.3.3.2	1384	PID2 Set Point 2 Min Use this parameter to set the minimum value for the set point 2 source.	2,3	RW
P8.3.3.3	1385	PID2 Set Point 2 Max Use this parameter to set the maximum value for the set point 2 source.	2,3	RW
P8.3.3.4	1386	PID2 Set Point 2 Sleep Enable Use this parameter to enable PID Set Point Sleep mode function. When enabled this function will disable the output when the frequency drops below the sleep frequency for the sleep delay time. The output re engages when feedback rises above the wakeup level. When the function is disabled the drive will run at the minimum or maximum defined speed.	2,3	RW
P8.3.3.5	2399	PID2 Set Point 2 Sleep Unit Sel Use this parameter to define the variable used when going into the sleep mode. 0 = Output Frequency 1 = Motor Speed 2 = Motor Current 3 = PID1 Feedback	2,3	RW
P8.3.3.6	2456	PID2 Set Point 2 Sleep Level Use this parameter to set the level of which the unit value is used to look at to go into the sleep mode. When the unit drops below or goes above this level for the sleep delay time it will put the drive into the sleep mode.	2,3	RW
P8.3.3.7	1388	PID2 Set Point 2 Sleep Delay Use this parameter sets the minimum time after the variable drops below the Sleep level for this amount of time that the output will shutoff.	2,3	RW
P8.3.3.8	1389	PID2 Set Point 2 WakeUp Level Use this parameter to set the level for the drive wakes up form the sleep mode condition. This level is variable based off the wake up action selection.	2,3	RW
P8.3.3.9	1391	PID2 Set Point 2 Boost Use this parameter to set the value the set point can be boosted when going into sleep mode. This is an additive variable that will add to the setpoint before drive output goes to sleep to prevent premature cycling.	2,3	RW
P8.3.3.10	1416	PID2 Set Point 2 Comp Enable Use this parameter to enables pressure loss compensation for set point 2 signal value. This is used in pump systems to compensate the pressure loss that occurs at the end of the pipe line due to the liquid flow.	2,3	RW

Appendix A—Description of parameters

Code	Modbus ID	Parameter	Application	RO/RW
P8.3.3.11	1417	PID2 Set Point 2 Comp Max	2,3	RW

Use this parameter to set the maximum compensation for the PID setpoint value that is applied to the output frequency of the drive is at its maximum frequency level. This value is added to the actual setpoint value as a function of the output frequency.
 Set Point Compensation = comp max * (output freq–min freq)/(max freq–min freq).

Procedure for setting up PID Application:

Initially set PID Gain(Para ID1356) to 0.0% and set the PID I Time (Para ID1357) to 20 sec. Start the frequency converter and verify if the set point is reached quickly while maintaining stable operation of the system. If not increase the PID Gain (Para ID1356) until the drive speed oscillates constantly. After this occurs reduce the PID Gain (Para ID1356) slightly to reduce the oscillation. From here take the value found for PID Gain (Para ID1356) to 0.5 times that value and reduce the PID I time (Para ID1357) until the feedback signal oscillates again. Increase the PID I time (Para ID1357) until the oscillation stops, with that value take it times 1.2 and use that value for the PID I time (Para ID1357). If signal noise is seen at high frequency increase the filter time value to filter the signal. If further tuning is required refer to the table showing what is effected.

Figure 70. Setting up PID application

Response	Rise time	Overshoot	Settling time	Steady state error
Increase PID Gain	Decrease Rise	Increases Overshoot	Not Affected	Decreases Error
Increase PID1 Time	Decrease Rise	Increases Overshoot	Increases Setting	Eliminates Error
Increase PID0 Time	Not Affected	Decreases Overshoot	Decreases Setting	Not Affected

Rise Time—the time required for the output to rise 90% of the desired level for the first time.

Overshoot—the difference between the peak level and the steady state level. Settling Time—time required for the system to converge to its steady state.

Steady State Error—the difference between the steady state level and the desired output level.

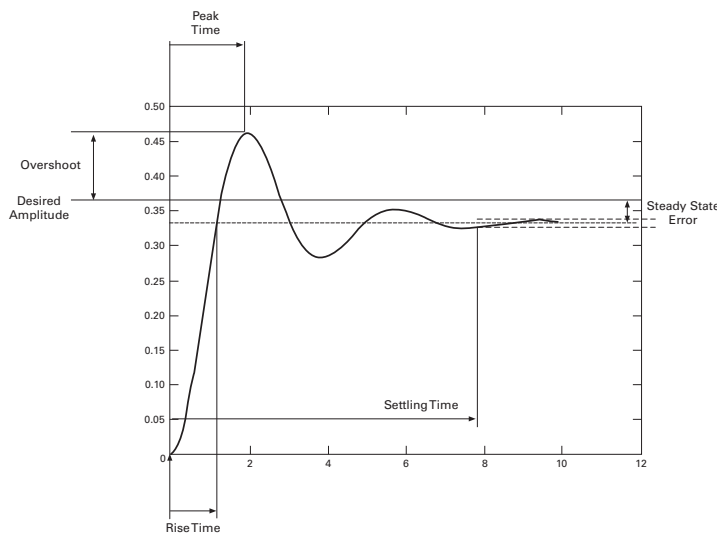

P8.2.3	2548	FB PID2 Set Point 2	2,3	RW
PID Set point value from Network. Can be assigned to PID Set Point Source				

P8.4.1.1	1392	PID2 Feedback Func	2,3	RW
Use this parameter to select if the feedback value is taken from a single signal or a combination of two signals. The mathematical functions can be selected that is used when two feedback signals are combined.				

P8.4.1.2	1393	PID2 Feedback Gain	2,3	RW
Use this parameter to set the gain associated with feedback signal from the measuring signals defined in the feedback function.				

P8.4.2.1	1394	PID2 Feedback 1 Source	2,3	RW
Use this parameter is used to select where feedback signal is being fed into the drive. This signal could be defined as analog inputs or fieldbus data value.				

Code	Modbus ID	Parameter	Application	RO/RW
P8.4.2.2	1395	PID2 Feedback 1 Min Use this parameter to set the minimum unit value for the feedback signal.	2,3	RW
P8.4.2.3	1396	PID2 Feedback 1 Max Use this parameter to set the maximum unit value for the feedback signal.	2,3	RW
P8.2.4	2552	FB PID2 Feedback 1 PID Feedback value from Network. Can be assigned to PID Feedback Source	2,3	RW
P8.4.3.1	1397	PID2 Feedback 2 Source Use this parameter is used to select where feedback signal is being fed into the drive. This signal could be defined as analog inputs or fieldbus data value.	2,3	RW
P8.4.3.2	1398	PID2 Feedback 2 Min Use this parameter to set the level of which the unit value is used to look at to go into the sleep mode. When the unit drops below or goes above this level for the sleep delay time it will put the drive into the sleep mode.	2,3	RW
P8.4.3.3	1399	PID2 Feedback 2 Max Use this parameter to set the maximum unit value for the feedback signal.	2,3	RW
P8.2.5	2553	FB PID2 Feedback 2 PID Feedback value from Network. Can be assigned to PID Feedback Source	2,3	RW
P8.5.1.1	1400	PID2 Feedforward Func Use this parameter to select if the feedforward value is taken form a single signal or a combination of two signals. The mathematical functions can be selected that is used when two feedback signals are combined.	2,3	RW
P8.5.1.2	1401	PID2 Feedforward Gain Use this parameter to set the gain associated with feedforward signal from the measuring signals defined in the feedback function.	2,3	RW
P8.5.2.1	1402	PID2 Feedforward 1 Source Use this parameter is used to select where feedforward signal is being fed into the drive. This signal could be defined as analog inputs or fieldbus data value.	2,3	RW
P8.5.2.2	1403	PID2 Feedforward 1 Min Use this parameter to set the minimum unit value for the feedforward signal.	2,3	RW
P8.5.2.3	1404	PID2 Feedforward 1 Max Use this parameter to set the maximum unit value for the feedforward signal.	2,3	RW
P8.2.6	2556	FB PID2 Feedforward 1 PID Feedforward value from Network. Can be assigned to PID Feedforward Source	2,3	RW
P8.5.3.1	1405	PID2 Feedforward 2 Source Use this paramter is used to select where feedforward signal is being fed into the drive. This signal could be defined as analog inputs or fieldbus data value.	2,3	RW
P8.5.3.2	1406	PID2 Feedforward 2 Min Use this parameter to set the minimum unit value for the feedforward signal.	2,3	RW
P8.5.3.3	1407	PID2 Feedforward 2 Max Use this parameter to set the maximum unit value for the feedforward signal.	2,3	RW
P8.2.7	2557	FB PID2 Feedforward 2 PID Feedforward value from Network. Can be assigned to PID Feedforward Source	2,3	RW
P9.1	535	Fire Mode Function Use this parameter to control whether the fire mode function is determined by a contact closure or contact opening on the desired digital input selections. 0 = Closing contact initiates fire mode function 1 = Opening contact initiates fire mode function Note: when Fire mode is enabled, this causes the drive to ignore any fault and run till its death. Warranty will be non valid in the case this is enabled and the drive causes issues to the system.	1,2,3	RW

Appendix A—Description of parameters

Code	Modbus ID	Parameter	Application	RO/RW
P9.2	536	Fire Mode Ref Select Function Use this parameter allows for setting the reference location for when the firemode is enabled. 0 = Fire Mode Min Frequency (see Para ID 537) 1 = Fire Mode Ref - follows Para ID 565 and ID 564 with the use of an digital input to select the active speed. 2 = Fieldbus Ref - Reference from fieldbus process in 3 = AI1 - Analog input 1 4 = AI2 - Analog input 2 5 = AI1 + AI2 - Analog input 1 added to Analog input 2 6 = PID1 Control Output - follows the PID control algorithm settings 7 = PID2 Control Output - follows the PID control algorithm settings	1,2,3	RW
P9.3	537	Fire Mode Min Frequency Use this parameter sets the minimum output frequency for fire mode, when reference selection is the min frequency.	1,2,3	RW
P9.4	565	Fire Mode Freq Ref 1 Use this parameter to set the fire mode frequency reference 1 when the ref selection mode is used.	1,2,3	RW
P9.5	564	Fire Mode Freq Ref 2 Use this parameter to set the fire mode frequency reference 2 when the ref selection mode is used.	1,2,3	RW
P9.6	2443	Fire Mode Test Enable Use this parameter to allows for testing the Fire Mode feature, with the parameter set to Enable and Fire Mode input enabled, the drive will run at the Fire Mode speed desired but all faults are still enabled.	1,2,3	RW
P9.7	554	Smoke Purge Frequency Use this parameter to set the frequency level in hz used when the input for smoke purge is enabled.	2,3	RW
P10.1.1	1418	Bypass Enable Use this parameter to enable the bypass functionality in the drive to have a soft key or input to force bypass.	1,2,3	RW
P10.1.2	544	Bypass Start Delay Use this parameter to set a time delay between when the Bypass Signal is applied via I/O, Fieldbus or keypad, to when the motor starts and once bypass is removed the time to switch back to drive.	1,2,3	RW
P10.1.3	542	Auto Bypass Use this parameter to enable whether an automatic switch to bypass will occur based on the selected faults below. 0 = Auto Bypass disabled 1 = Auto Bypass enabled	1,2,3	RW
P10.1.4	543	Auto Bypass Delay Use this parameter to set the time delay before an automatic switch to bypass.	1,2,3	RW
P10.1.5	547	OverCurrent Bypass Enable Use this parameter to enable an automatic switch to bypass when an overcurrent fault occurs. 0 = Disable Auto bypass on overcurrent fault 1 = Enable Auto bypass on overcurrent fault	1,2,3	RW
P10.1.6	546	IGBT Fault Bypass Enable Use this parameter to enable an automatic switch to bypass when an IGBT fault occurs. 0 = Disable Auto bypass on IGBT fault 1 = Enable Auto bypass on IGBT fault	1,2,3	RW
P10.1.7	548	4mA Fault Bypass Enable Use this parameter to enable an automatic switch to bypass when a loss of reference fault occurs. 0 = Disable Auto bypass on loss of reference fault 1 = Enable Auto bypass on loss of reference fault	1,2,3	RW
P10.1.8	545	UnderVoltage Bypass Enable Use this parameter to an automatic switch to bypass when an under voltage fault occurs. 0 = Disable Auto bypass on under voltage fault 1 = Enable Auto bypass on under voltage fault	1,2,3	RW

Code	Modbus ID	Parameter	Application	RO/RW
P10.1.9	549	OverVoltage Bypass Enable This parameter specifies whether an automatic switch to bypass when an overvoltage fault occurs. 0 = Disable Auto bypass on overvoltage fault 1 = Enable Auto bypass on overvoltage fault	1,2,3	RW
P10.1.10	1698	Motor OverTemp Bypass Enable This parameter specifies whether an automatic switch to bypass when an Motor Overtemp fault occurs. 0 = Disable Auto bypass on Motor Overtemp fault 1 = Enable Auto bypass on Motor Overtemp fault	1,2,3	RW
P10.1.11	1699	UnderLoad Bypass Enable This parameter specifies whether an automatic switch to bypass when an UnderLoad fault occurs. 0 = Disable Auto bypass on UnderLoad fault 1 = Enable Auto bypass on UnderLoad fault	1,2,3	RW
P10.1.12	1700	External Bypass Enable This parameter specifies whether an automatic switch to bypass when an External fault occurs. 0 = Disable Auto bypass on External fault 1 = Enable Auto bypass on External fault	1,2,3	RW
P10.1.13	1701	Charge Switch Fault Bypass Enable This parameter specifies whether an automatic switch to bypass when an Charge Switch fault occurs. 0 = Disable Auto bypass on Charge Switch fault 1 = Enable Auto bypass on Charge Switch fault	1,2,3	RW
P10.1.14	1702	Saturation Trip Fault Bypass Enable This parameter specifies whether an automatic switch to bypass when an Saturation fault occurs. 0 = Disable Auto bypass on Saturation fault 1 = Enable Auto bypass on Saturation fault	1,2,3	RW
P10.1.15	1703	Under Temp Fault Bypass Enable This parameter specifies whether an automatic switch to bypass when an UnderTemp fault occurs. 0 = Disable Auto bypass on UnderTemp fault 1 = Enable Auto bypass on UnderTemp fault	1,2,3	RW
P10.1.16	1704	EEPROM Fault Bypass Enable This parameter specifies whether an automatic switch to bypass when an Charge Switch fault occurs. 0 = Disable Auto bypass on Charge Switch fault 1 = Enable Auto bypass on Charge Switch fault	1,2,3	RW
P10.1.17	1705	FRAM Fault Bypass Enable This parameter specifies whether an automatic switch to bypass when an Charge Switch fault occurs. 0 = Disable Auto bypass on Charge Switch fault 1 = Enable Auto bypass on Charge Switch fault	1,2,3	RW
P10.1.18	1706	Watchdog Fault Bypass Enable This parameter specifies whether an automatic switch to bypass when an Watchdog fault occurs. 0 = Disable Auto bypass on Watchdog fault 1 = Enable Auto bypass on Watchdog fault	1,2,3	RW
P10.1.19	1707	Fan Cooling Fault Bypass Enable This parameter specifies whether an automatic switch to bypass when an Fan Cooling fault occurs. 0 = Disable Auto bypass on Fan Cooling fault 1 = Enable Auto bypass on Fan Cooling fault	1,2,3	RW
P10.1.20	1708	Keypad Com Fault Bypass Enable This parameter specifies whether an automatic switch to bypass when an Keypad Communication fault occurs. 0 = Disable Auto bypass on Keypad Communication fault 1 = Enable Auto bypass on Keypad Communication fault	1,2,3	RW
P10.1.21	1709	Option Card Fault Bypass Enable This parameter specifies whether an automatic switch to bypass when an Charge Switch fault occurs. 0 = Disable Auto bypass on Charge Switch fault 1 = Enable Auto bypass on Charge Switch fault	1,2,3	RW

Appendix A—Description of parameters

Code	Modbus ID	Parameter	Application	RO/RW
P10.1.22	1710	RTC Clock Fault Bypass Enable This parameter specifies whether an automatic switch to bypass when an Charge Switch fault occurs. 0 = Disable Auto bypass on Charge Switch fault 1 = Enable Auto bypass on Charge Switch fault	1,2,3	RW
P10.1.23	1711	Ctrl Board OverTemp Fault Bypass Enable This parameter specifies whether an automatic switch to bypass when an Charge Switch fault occurs. 0 = Disable Auto bypass on Charge Switch fault 1 = Enable Auto bypass on Charge Switch fault	1,2,3	RW
P10.1.24	1712	Speed Search Start Fault Bypass Enable This parameter specifies whether an automatic switch to bypass when an Speed Search Start fault occurs. 0 = Disable Auto bypass on Speed Search Start fault 1 = Enable Auto bypass on Speed Search Start fault	1,2,3	RW
P10.1.25	1713	Fieldbus Fault Bypass Enable This parameter specifies whether an automatic switch to bypass when an Fieldbus fault occurs. 0 = Disable Auto bypass on Fieldbus fault 1 = Enable Auto bypass on Fieldbus fault	1,2,3	RW
P10.2.1	2476	Redundant Drive Enable Use this parameter to enable the Redundant drive setup where multiple drives can be connected via Para communications to start if the main drive fails or runtime settings below expires.	2,3	RW
P10.2.2	2278	Drive ID Use this parameter to set the drive address when using multi drive redundant mode, based off this id the drive enables in the desired sequence and can be monitored at this drive ID value in the monitor screen.	2,3	RW
P10.2.3	2477	Redundant Run Time Enable Use this parameter to enables the Run time limit for the Redundant drive mode so that drives will be cycled based off the Run time limit value.	2,3	RW
P10.2.4	2478	Redundant Run Time Reset Use this parameter to manually Reset the Redundant Drive Run timer.	2,3	RW
P10.2.5	2479	Redundant RunTime Limit Use this paramter to set the time limit for Run time of the drive when enabled for the Redundant drive scheme.	2,3	RW
P11.1.1	2487	Interval 1 Setting Use this parameter with the Interval time setting for interval 1 to set the desired time frame for the selection; to be Weekly or Daily. 0 - Weekly - would setup the timer for the week long. Drive starts on the on day/time and runs to the stop day and time. 1 - Daily - would setup the timer for the defined day. Drive starts on time and stops on that day off time, for the listed days in the sequence	2,3	RW
P11.1.2	491	Interval 1 On Time Use this parameter to set the on time for Interval function. It uses 24-hour format. Use to specify a time of day for a desired function to be disabled.	2,3	RW
P11.1.3	493	Interval 1 Off Time Use this parameter to set the off time for Interval function. It uses 24-hour format. Use to specify a time of day for a desired function to be disabled.	2,3	RW
P11.1.4	517	Interval 1 From Day Use this parameter to set the day of week for Interval function to start on. 0 = Sunday 1 = Monday 2 = Tuesday 3 = Wednesday 4 = Thursday 5 = Friday 6 = Saturday	2,3	RW

Code	Modbus ID	Parameter	Application	RO/RW
P11.1.5	518	Interval 1 To Day Use this parameter to set the day of week for Interval function to stop on. 0 = Sunday 1 = Monday 2 = Tuesday 3 = Wednesday 4 = Thursday 5 = Friday 6 = Saturday	2,3	RW
P11.1.6	519	Interval 1 Channel Use this parameter to assign the interval to a select time channel to store the interval time. 0 = Not used 1 = Time channel 1 2 = Time channel 2 3 = Time channel 3	2,3	RW
P11.2.1	2488	Interval 2 Setting Use this parameter with the Interval time setting for interval 2 to set the desired time frame for the selection; to be Weekly or Daily. 0 - Weekly - would setup the timer for the week long. Drive starts on the on day/time and runs to the stop day and time. 1 - Daily - would setup the timer for the defined day. Drive starts on time and stops on that day off time, for the listed days in the sequence	2,3	RW
P11.2.2	495	Interval 2 On Time Use this parameter to set the on time for Interval function. It uses 24-hour format. Use to specify a time of day for a desired function to be disabled.	2,3	RW
P11.2.3	497	Interval 2 Off Time Use this parameter to set the off time for Interval function. It uses 24-hour format. Use to specify a time of day for a desired function to be disabled.	2,3	RW
P11.2.4	520	Interval 2 From Day Use this parameter to set the day of week for Interval function to start on. 0 = Sunday 1 = Monday 2 = Tuesday 3 = Wednesday 4 = Thursday 5 = Friday 6 = Saturday	2,3	RW
P11.2.5	521	Interval 2 To Day Use this parameter to set the day of week for Interval function to stop on. 0 = Sunday 1 = Monday 2 = Tuesday 3 = Wednesday 4 = Thursday 5 = Friday 6 = Saturday	2,3	RW
P11.2.6	522	Interval 2 Channel Use this parameter to assign the interval to a select time channel to store the interval time. 0 = Not used 1 = Time channel 1 2 = Time channel 2 3 = Time channel 3	2,3	RW
P11.3.1	2489	Interval 3 Setting Use this parameter with the Interval time setting for interval 3 to set the desired time frame for the selection; to be Weekly or Daily. 0 - Weekly - would setup the timer for the week long. Drive starts on the on day/time and runs to the stop day and time. 1 - Daily - would setup the timer for the defined day. Drive starts on time and stops on that day off time, for the listed days in the sequence	2,3	RW
P11.3.2	499	Interval 3 On Time Use this parameter to set the on time for Interval function. It uses 24-hour format. Use to specify a time of day for a desired function to be disabled.	2,3	RW

Appendix A—Description of parameters

Code	Modbus ID	Parameter	Application	RO/RW
P11.3.3	501	Interval 3 Off Time Use this parameter to set the off time for Interval function. It uses 24-hour format. Use to specify a time of day for a desired function to be disabled.	2,3	RW
P11.3.4	523	Interval 3 From Day Use this parameter to set the day of week for Interval function to start on. 0 = Sunday 1 = Monday 2 = Tuesday 3 = Wednesday 4 = Thursday 5 = Friday 6 = Saturday	2,3	RW
P11.3.5	524	Interval 3 To Day Use this parameter to set the day of week for Interval function to stop on. 0 = Sunday 1 = Monday 2 = Tuesday 3 = Wednesday 4 = Thursday 5 = Friday 6 = Saturday	2,3	RW
P11.3.6	525	Interval 3 Channel Use this parameter to assign the interval to a select time channel to store the interval time. 0 = Not used 1 = Time channel 1 2 = Time channel 2 3 = Time channel 3	2,3	RW
P11.4.1	2490	Interval 4 Setting Use this parameter with the Interval time setting for interval 4 to set the desired time frame for the selection; to be Weekly or Daily. 0 - Weekly - would setup the timer for the week long. Drive starts on the on day/time and runs to the stop day and time. 1 - Daily - would setup the timer for the defined day. Drive starts on time and stops on that day off time, for the listed days in the sequence	2,3	RW
P11.4.2	503	Interval 4 On Time Use this parameter to set the on time for Interval function. It uses 24-hour format. Use to specify a time of day for a desired function to be disabled.	2,3	RW
P11.4.3	505	Interval 4 Off Time Use this parameter to set the off time for Interval function. It uses 24-hour format. Use to specify a time of day for a desired function to be disabled.	2,3	RW
P11.4.4	526	Interval 4 From Day Use this parameter to set the day of week for Interval function to start on. 0 = Sunday 1 = Monday 2 = Tuesday 3 = Wednesday 4 = Thursday 5 = Friday 6 = Saturday	2,3	RW
P11.4.5	527	Interval 4 To Day Use this parameter to set the day of week for Interval function to stop on. 0 = Sunday 1 = Monday 2 = Tuesday 3 = Wednesday 4 = Thursday 5 = Friday 6 = Saturday	2,3	RW

Code	Modbus ID	Parameter	Application	RO/RW
P11.4.6	528	Interval 4 Channel Use this parameter to assign the interval to a select time channel to store the interval time. 0 = Not used 1 = Time channel 1 2 = Time channel 2 3 = Time channel 3	2,3	RW
P11.5.1	2491	Interval 5 Setting Use this parameter with the Interval time setting for interval 5 to set the desired time frame for the selection; to be Weekly or Daily. 0 - Weekly - would setup the timer for the week long. Drive starts on the on day/time and runs to the stop day and time. 1 - Daily - would setup the timer for the defined day. Drive starts on time and stops on that day off time, for the listed days in the sequence	2,3	RW
P11.5.2	507	Interval 5 On Time Use this parameter to set the on time for Interval function. It uses 24-hour format. Use to specify a time of day for a desired function to be disabled.	2,3	RW
P11.5.3	509	Interval 5 Off Time Use this parameter to set the off time for Interval function. It uses 24-hour format. Use to specify a time of day for a desired function to be disabled.	2,3	RW
P11.5.4	529	Interval 5 From Day Use this parameter to set the day of week for Interval function to start on. 0 = Sunday 1 = Monday 2 = Tuesday 3 = Wednesday 4 = Thursday 5 = Friday 6 = Saturday	2,3	RW
P11.5.5	530	Interval 5 To Day Use this parameter to set the day of week for Interval function to stop on. 0 = Sunday 1 = Monday 2 = Tuesday 3 = Wednesday 4 = Thursday 5 = Friday 6 = Saturday	2,3	RW
P11.5.6	531	Interval 5 Channel Use this parameter to assign the interval to a select time channel to store the interval time. 0 = Not used 1 = Time channel 1 2 = Time channel 2 3 = Time channel 3	2,3	RW
P11.6.1	511	Timer 1 Duration Use this parameter to set the duration of time the timer will run when activated. (Activated by DI)	2,3	RW
P11.6.2	532	Timer 1 Channel Use this parameter to assign the interval to a select time channel to store the timer channel. 0 = Not used 1 = Time channel 1 2 = Time channel 2 3 = Time channel 3	2,3	RW
P11.6.3	513	Timer 2 Duration Use this parameter to set the duration of time the timer will run when activated. (Activated by DI)	2,3	RW
P11.6.4	533	Timer 2 Channel Use this parameter to assign the interval to a select time channel to store the timer channel. 0 = Not used 1 = Time channel 1 2 = Time channel 2 3 = Time channel 3	2,3	RW

Appendix A—Description of parameters

Code	Modbus ID	Parameter	Application	RO/RW
P11.6.5	515	Timer 3 Duration Use this parameter to set the duration of time the timer will run when activated. (Activated by DI)	2,3	RW
P11.6.6	534	Timer 3 Channel Use this parameter to assign the interval to a select time channel to store the timer channel. 0 = Not used 1 = Time channel 1 2 = Time channel 2 3 = Time channel 3	2,3	RW
P12.1.1	2533	FB Process Data Input 1 Sel Use this parameter to assign the Fieldbus Data Input Selections, parameter/monitor Para ID's can be assigned to these registers and then written over the desired Fieldbus Network Word for Process Data. See Communication Manual for more details.	1,2,3	RW
P12.1.2	2534	FB Process Data Input 2 Sel Use this parameter to assign the Fieldbus Data Input Selections, parameter/monitor Para ID's can be assigned to these registers and then written over the desired Fieldbus Network Word for Process Data. See Communication Manual for more details.	1,2,3	RW
P12.1.3	2535	FB Process Data Input 3 Sel Use this parameter to assign the Fieldbus Data Input Selections, parameter/monitor Para ID's can be assigned to these registers and then written over the desired Fieldbus Network Word for Process Data. See Communication Manual for more details.	1,2,3	RW
P12.1.4	2536	FB Process Data Input 4 Sel Use this parameter to assign the Fieldbus Data Input Selections, parameter/monitor Para ID's can be assigned to these registers and then written over the desired Fieldbus Network Word for Process Data. See Communication Manual for more details.	1,2,3	RW
P12.1.5	2537	FB Process Data Input 5 Sel Use this parameter to assign the Fieldbus Data Input Selections, parameter/monitor Para ID's can be assigned to these registers and then written over the desired Fieldbus Network Word for Process Data. See Communication Manual for more details.	1,2,3	RW
P12.1.6	2538	FB Process Data Input 6 Sel Use this parameter to assign the Fieldbus Data Input Selections, parameter/monitor Para ID's can be assigned to these registers and then written over the desired Fieldbus Network Word for Process Data. See Communication Manual for more details.	1,2,3	RW
P12.1.7	2539	FB Process Data Input 7 Sel Use this parameter to assign the Fieldbus Data Input Selections, parameter/monitor Para ID's can be assigned to these registers and then written over the desired Fieldbus Network Word for Process Data. See Communication Manual for more details.	1,2,3	RW
P12.1.8	2540	FB Process Data Input 8 Sel Use this parameter to assign the Fieldbus Data Input Selections, parameter/monitor Para ID's can be assigned to these registers and then written over the desired Fieldbus Network Word for Process Data. See Communication Manual for more details.	1,2,3	RW
P12.2.1	1556	FB Process Data Output 1 Sel Use this parameter to accessing the Fieldbus Data Output Selections, parameter/monitor ID's can be assigned to these registers and then read over the desired Fieldbus Network Word for Process Data. Default Values for Process Data Out in Fieldbus(build table for below values) Process Data Out1 - Output Frequency = ID 1 Process Data Out2 - Motor Speed = ID 2 Process Data Out3 - Motor Current = ID 3 Process Data Out4 - Motor Torque = ID 4 Process Data Out5 - Motor Power = ID 5 Process Data Out6 - Motor Voltage = ID 6 Process Data Out7 - DC Link Voltage = ID 7 Process Data Out8 - Active Fault Code = ID 28 See Communication Manual for more details.	1,2,3	RW

Code	Modbus ID	Parameter	Application	RO/RW
P12.2.2	1557	FB Process Data Output 2 Sel Use this parameter to accessing the Fieldbus Data Output Selections, parameter/monitor ID's can be assigned to these registers and then read over the desired Fieldbus Network Word for Process Data. Default Values for Process Data Out in Fieldbus(build table for below values) Process Data Out1 - Output Frequency = ID 1 Process Data Out2 - Motor Speed = ID 2 Process Data Out3 - Motor Current = ID 3 Process Data Out4 - Motor Torque = ID 4 Process Data Out5 - Motor Power = ID 5 Process Data Out6 - Motor Voltage = ID 6 Process Data Out7 - DC Link Voltage = ID 7 Process Data Out8 - Active Fault Code = ID 28 See Communication Manual for more details.	1,2,3	RW
P12.2.3	1558	FB Process Data Output 3 Sel Use this parameter to accessing the Fieldbus Data Output Selections, parameter/monitor ID's can be assigned to these registers and then read over the desired Fieldbus Network Word for Process Data. Default Values for Process Data Out in Fieldbus(build table for below values) Process Data Out1 - Output Frequency = ID 1 Process Data Out2 - Motor Speed = ID 2 Process Data Out3 - Motor Current = ID 3 Process Data Out4 - Motor Torque = ID 4 Process Data Out5 - Motor Power = ID 5 Process Data Out6 - Motor Voltage = ID 6 Process Data Out7 - DC Link Voltage = ID 7 Process Data Out8 - Active Fault Code = ID 28 See Communication Manual for more details.	1,2,3	RW
P12.2.4	1559	FB Process Data Output 4 Sel Use this parameter to accessing the Fieldbus Data Output Selections, parameter/monitor ID's can be assigned to these registers and then read over the desired Fieldbus Network Word for Process Data. Default Values for Process Data Out in Fieldbus(build table for below values) Process Data Out1 - Output Frequency = ID 1 Process Data Out2 - Motor Speed = ID 2 Process Data Out3 - Motor Current = ID 3 Process Data Out4 - Motor Torque = ID 4 Process Data Out5 - Motor Power = ID 5 Process Data Out6 - Motor Voltage = ID 6 Process Data Out7 - DC Link Voltage = ID 7 Process Data Out8 - Active Fault Code = ID 28 See Communication Manual for more details.	1,2,3	RW
P12.2.5	1560	FB Process Data Output 5 Sel Use this parameter to accessing the Fieldbus Data Output Selections, parameter/monitor ID's can be assigned to these registers and then read over the desired Fieldbus Network Word for Process Data. Default Values for Process Data Out in Fieldbus(build table for below values) Process Data Out1 - Output Frequency = ID 1 Process Data Out2 - Motor Speed = ID 2 Process Data Out3 - Motor Current = ID 3 Process Data Out4 - Motor Torque = ID 4 Process Data Out5 - Motor Power = ID 5 Process Data Out6 - Motor Voltage = ID 6 Process Data Out7 - DC Link Voltage = ID 7 Process Data Out8 - Active Fault Code = ID 28 See Communication Manual for more details.	1,2,3	RW
P12.2.6	1561	FB Process Data Output 6 Sel Use this parameter to accessing the Fieldbus Data Output Selections, parameter/monitor ID's can be assigned to these registers and then read over the desired Fieldbus Network Word for Process Data. Default Values for Process Data Out in Fieldbus(build table for below values) Process Data Out1 - Output Frequency = ID 1 Process Data Out2 - Motor Speed = ID 2 Process Data Out3 - Motor Current = ID 3 Process Data Out4 - Motor Torque = ID 4 Process Data Out5 - Motor Power = ID 5 Process Data Out6 - Motor Voltage = ID 6 Process Data Out7 - DC Link Voltage = ID 7 Process Data Out8 - Active Fault Code = ID 28 See Communication Manual for more details.	1,2,3	RW

Appendix A—Description of parameters

Code	Modbus ID	Parameter	Application	RO/RW
P12.2.7	1562	FB Process Data Output 7 Sel Use this parameter to accessing the Fieldbus Data Output Selections, parameter/monitor ID's can be assigned to these registers and then read over the desired Fieldbus Network Word for Process Data. Default Values for Process Data Out in Fieldbus(build table for below values) Process Data Out1 - Output Frequency = ID 1 Process Data Out2 - Motor Speed = ID 2 Process Data Out3 - Motor Current = ID 3 Process Data Out4 - Motor Torque = ID 4 Process Data Out5 - Motor Power = ID 5 Process Data Out6 - Motor Voltage = ID 6 Process Data Out7 - DC Link Voltage = ID 7 Process Data Out8 - Active Fault Code = ID 28 See Communication Manual for more details.	1,2,3	RW
P12.2.8	1563	FB Process Data Output 8 Sel Use this parameter to accessing the Fieldbus Data Output Selections, parameter/monitor ID's can be assigned to these registers and then read over the desired Fieldbus Network Word for Process Data. Default Values for Process Data Out in Fieldbus(build table for below values) Process Data Out1 - Output Frequency = ID 1 Process Data Out2 - Motor Speed = ID 2 Process Data Out3 - Motor Current = ID 3 Process Data Out4 - Motor Torque = ID 4 Process Data Out5 - Motor Power = ID 5 Process Data Out6 - Motor Voltage = ID 6 Process Data Out7 - DC Link Voltage = ID 7 Process Data Out8 - Active Fault Code = ID 28 See Communication Manual for more details.	1,2,3	RW
P12.2.9	2415	Standard Status Word Bit0 Function Select Use this parameter to select status indication of this bit0 to be read over the communication Standard Status Word.	1,2,3	RW
P12.2.10	2416	Standard Status Word Bit1 Function Select Use this parameter to select status indication of this bit1 to be read over the communication Standard Status Word.	1,2,3	RW
P12.2.11	2417	Standard Status Word Bit2 Function Select Use this parameter to select status indication of this bit2 to be read over the communication Standard Status Word.	1,2,3	RW
P12.2.12	2418	Standard Status Word Bit3 Function Select Use this parameter to select status indication of this bit3 to be read over the communication Standard Status Word.	1,2,3	RW
P12.2.13	2419	Standard Status Word Bit4 Function Select Use this parameter to select status indication of this bit4 to be read over the communication Standard Status Word.	1,2,3	RW
P12.2.14	2420	Standard Status Word Bit5 Function Select Use this parameter to select status indication of this bit5 to be read over the communication Standard Status Word.	1,2,3	RW
P12.2.15	2421	Standard Status Word Bit6 Function Select Use this parameter to select status indication of this bit6 to be read over the communication Standard Status Word.	1,2,3	RW
P12.2.16	2422	Standard Status Word Bit7 Function Select Use this parameter to select status indication of this bit7 to be read over the communication Standard Status Word.	1,2,3	RW
P12.3.1.1	586	RS485 Comm Set This parameter to select the communication protocol for RS-485 terminals. 0 = Modbus RTU 1 = BACnet MS/TP 2 = SA Bus	1,2,3	RW
P12.3.2.1	587	Slave Address Use this parameter set the slave address for RS-485 communication.	1,2,3	RW

Code	Modbus ID	Parameter	Application	RO/RW
P12.3.2.2	584	Baud Rate Use this parameter set communication speed for RS-485 communication.	1,2,3	RW
P12.3.2.3	585	Parity Type Use this parameter set parity type for RS-485 communication.	1,2,3	RW
P12.3.2.4	588	Modbus RTU Protocol Status Use this parameter to show the protocol status for RS-485 communication. 0 = Initial 1 = Stopped 2 = Operational 3 = Faulted	1,2,3	RO
P12.3.2.5	593	Comm Timeout Modbus RTU Use this parameter to set the time it waits before a communication fault occurs over Modbus RTU if a message isn't received.	1,2,3	RW
P12.3.2.6	2516	Modbus RTU Fault Response Use this parameter to set the the Fieldbus Fault condition for Modbus RTU Communication. 0 = Only in Fieldbus Control Mode - when Fieldbus is the control place and Fieldbus fault is active drive will fault on loss of coms, if not in Fieldbus Control place will not fault. 1 = In all Control Modes - no matter the control place setting if communication is lost Fieldbus fault response will occur.	1,2,3	RW
P12.3.3.1	594	MSTP Baud Rate Use this parameter to set the communication speed over BACnet.	1,2,3	RW
P12.3.3.2	595	MSTP Device Address Use this parameter to set the BACnet Address that the drive will be located at on Instance node.	1,2,3	RW
P12.3.3.3	596	MSTP Instance Number Use this parameter to set the the BACnet Instance value.	1,2,3	RW
P12.3.3.4	598	MSTP Comm Timeout Use this parameter to set the time it waits before a communication fault occurs over BACnet.	1,2,3	RW
P12.3.3.5	599	MSTP Protocol Status Use this parameter to see the status of the BACnet Protocol.	1,2,3	RO
P12.3.3.6	600	MSTP Fault Code Use this parameter to see the status of the BACnet Protocol faults 0 = None 1 = Sole Master	1,2,3	RO
P12.3.3.7	2526	MSTP Fault Response Use this parameter to set the Fieldbus Fault condition for Modbus RTU and BACnet Communication. 0 = Only in Fieldbus Control Mode - when fieldbus is the control place and Fieldbus fault is active drive will fault on loss of coms, if not in Fieldbus Control place will not fault. 1 = In all Control Modes - no matter the control place setting if communication is lost Fieldbus fault response will occur.	1,2,3	RW
P12.3.3.8	1537	MSTP Max Master Use this parameter to set the maximum number of devices used on the network. This will prevent additional traffic scanning on the network.	1,2,3	RW
P12.3.4.1	1727	SA Bus Baud Rate Select the communication speed for the network.	1,2,3	RW
P12.3.4.2	1726	SA Bus Device Address The address of the device on the network. Each device to have unique address in the network.	1,2,3	RW
P12.3.4.3	1728	SA Bus Instance Number The Device Object's Instance number is used in conjunction with the MAC address to assign the devices on the network. The instance number can have up to 127 nodes on it before a different instance number is required.	1,2,3	RW

Appendix A—Description of parameters

Code	Modbus ID	Parameter	Application	RO/RW
P12.3.4.4	1730	SA Bus Comm Timeout Communication error is initiated if the drive is a "Sole Master" in the network for a time more than defined with this parameter.	1,2,3	RW
P12.3.4.5	1731	SA Bus Protocol Status Fieldbus Protocol Status tells the status of the protocol.	1,2,3	RO
P12.3.4.6	1732	SA Bus Fault Response Defines when Fieldbus fault to be raised if fault condition is detected	1,2,3	RW
P12.4.1.3	1509	Active Subnet Mask Use this parameter to see the current used subnet mask.	1,2,3	RO
P12.4.1.4	1511	Active Default Gateway Use this parameter to see the current used default gateway.	1,2,3	RO
P12.4.1.5	1513	MAC Address Use this parameter to see the 48 bit hardware address.	1,2,3	RO
P12.4.1.6	1501	Static IP Address Use this parameter to set the static IP address.	1,2,3	RW
P12.4.1.7	1503	Static Subnet Mask Use this parameter to set the static subnet mask.	1,2,3	RW
P12.4.1.8	1505	Static Default Gateway Use this parameter to set the static gateway ip address.	1,2,3	RW
P12.4.1.9	1725	Enable BACnetIP Use this parameter to enable the BACnetIP mode, when enabled this disables the BACnet MSTP control. When this parameter is enabled, other parameters in menu becomes visible, else they are hidden. 0 = Disable 1 = Enable	1,2,3	RW
P12.4.2.1	609	Connection Limit Use this parameter to set the maximum number of connections allowed to the frequency converter.	1,2,3	RO
P12.4.2.2	610	Modbus TCP Unit ID Use this parameter to set the unit identifier value for Modbus TCP.	1,2,3	RW
P12.4.2.3	611	Comm Timeout Modbus TCP Use this parameter to set the time it waits before a communication fault occurs over Ethernet.	1,2,3	RW
P12.4.2.4	612	Modbus TCP Protocol Status Use this parameter to show the Modbus TCP Protocol is active or not. 0 = Stopped 1 = Operational 2 = Faulted	1,2,3	RO
P12.4.2.5	2517	Modbus TCP Fault Response Use this parameter to set the Fieldbus Fault condition for Modbus TCP Communication. 0 = Only in Fieldbus Control Mode - when fieldbus is the control place and Fieldbus fault is active drive will fault on loss of coms, if not in Fieldbus Control place will not fault. 1 = In all Control Modes - no matter the control place setting if communication is lost Fieldbus fault response will occur.	1,2,3	RW
P12.4.3.1	1733	BACnet IP UDP port number The UDP port for the BACnet IP communication.	1,2,3	RW
P12.4.3.2	1734	BACnet IP Foreign Device The foreign device feature is used when the device is located in a different network than the BBMD. A normal router does not send broadcast messages between different networks. The 'Foreign device' feature solves this problem by establishing a connection to the BBMD with unicast messages. All broadcast messages are forwarded to a BBMD device that takes care of receiving and transmitting broadcast messages in both directions for all foreign devices.	1,2,3	RW

Code	Modbus ID	Parameter	Application	RO/RW
P12.4.3.3	1735	BACnet IP BBMD IP The IP address of the BACnet IP Broadcast Management Device.	1,2,3	RW
P12.4.3.4	1737	BACnet IP BBMD Port The BBMD Port number.	1,2,3	RW
P12.4.3.5	1738	BACnet IP Registration Interval The registration interval to keep a live connection to the BBMD. Unit is seconds.	1,2,3	RW
P12.4.3.6	1739	BACnet IP Comm Timeout Defines the number of seconds after a timeout is indicated after a communication break or disconnected EtherNet link. Value 0 disables communication link supervision.	1,2,3	RW
P12.4.3.7	1740	BACnet IP Protocol Status Fieldbus Protocol Status tells the status of the protocol.	1,2,3	RO
P12.4.3.8	1741	BACnet IP Fault Behavior Defines when Fieldbus fault to be raise if fault condition is detected.	1,2,3	RW
P12.4.3.9	1742	BACnetIP Instance Number The Device Object's Instance number is used in conjunction with the MAC address to assign the devices on the network. The instance number can have up to 127 nodes on it before a different instance number is required.	1,2,3	RW
P13.1.1	340	Language Use this parameter to allow to control the frequency converter through the keypad in the language of your choice.	1,2,3	RW
P13.1.2	142	Application Use this parameter to set the active application marco to use.	1,2,3	RW
P13.1.3	619	Parameter Sets Use this parameter to reload the factory default parameter values, and to store and load two customized parameter sets. 0 = No 1 = Reload Default 2 = Reload Set #1 3 = Reload Set #2; 4 = Store Set #1; 5 = Store Set #2; 6 = Reset; 7 = Reload Defaults VM	1,2,3	RW
P13.1.4	620	Up To Keypad Use this parameter to enable uploading all parameter to the keypad. 0 = No 1 = Yes (All parameters)	1,2,3	RW
P13.1.5	621	Down From Keypad Use this parameter to enable downloading parameter from the keypad. 0 = No 1 = All parameters 2 = All Parameter, No Motor 3 = App Parameter	1,2,3	RW
P13.1.6	623	Parameter Comparison Use this parameter to initiate a Parameter Comparison function, you can compare the actual parameter values to the values of your customized parameter sets and those loaded to the control keypad. The actual parameter values are first compared to those of the customized parameter Set1. If no differences are detected, a "0" is displayed on the lowermost line of the keypad. If any of the parameter values differ from those of the Set1 parameters, the number of the deviations is displayed together. By pressing the right arrow button once again you will see both the actual value and the value it was compared to. In this display, the value on the Description line (in the middle) is the default value, and the one on the value line (lowermost line) is the edited value. You can also edit the actual value by pushing the Right Arrow button. Actual values can also be compared to Set2, Factory Settings and Keypad Set values.	1,2,3	RW

Appendix A—Description of parameters

Code	Modbus ID	Parameter	Application	RO/RW
P13.1.7	624	<p>Password</p> <p>Use this parameter to setup a password to protected against unauthorized changes. When the password function is enabled, the user will be prompted to enter a password before application changes, parameter value changes, or password changes. By default, the password function is not in use. If you want to activate the password, change the value of this parameter to any number between 1 and 9999. To deactivate the password, reset the parameter value to 0.</p>	1,2,3	RW
P13.1.8	625	<p>Parameter Lock</p> <p>Use this parameter to prevent user from changing parameters. User has to come to thie parameter to allow changing. When the parameter lock is activated the text *locked* will appear on the display if you try to edit a parameter value. Note: This function does not prevent unauthorized editing of parameter values.</p>	1,2,3	RW
P13.1.9	627	<p>Multimonitor Set</p> <p>Use this parameter lock in the values set for the mult-monitor page and not allow changing unless re enabled.</p>	1,2,3	RW
P13.1.10	628	<p>Default Page</p> <p>This parameter sets the view to which the display automatically moves as the Timeout Time expires or when the keypad power is switched on. If the Default Page value is 0, the function is not activated, i.e., the last displayed page remains on the keypad display.</p>	1,2,3	RW
P13.1.11	629	<p>Timeout Time</p> <p>Use this parameter to set the time after which the keypad display returns to the Default Page, if no keypad keys are pressed. Note: If the Default Page value is 0 the Timeout Time setting has no effect.</p>	1,2,3	RW
P13.1.12	630	<p>Contrast Adjust</p> <p>Use this parameter to adjust the display by changing the contrast.</p>	1,2,3	RW
P13.1.13	631	<p>Backlight Time</p> <p>Use this parameter to set the time to illuminate the display.</p>	1,2,3	RW
P13.1.14	632	<p>Fan Control</p> <p>This function allows you to control the drives cooling fan. You can set the fan to run: 0 = Continuous—fan runs continuously. 1 = Temperature—based on the temperature of the unit. The fan is switched on automatically when the heat sink temperature reaches 60°C. The fan receives a stop command when the heat sink temperature falls to 55°C. The fan runs for about a minute after receiving the stop command or switching on the power, as well as after changing the value from “Continuous” to “Temperature.” 2 = Run Follow —after power up, the fan is stopped until the run command is given and then fan runs continuously. This is mainly made for common DC-bus systems to prevent cooling fans to load charging resistors on power up moment. 3 = Calculate IGBT Temp—starting of cooling fan is based on calculated IGBT temperature. When IGBT temp = 40°C, fan starts and when temp falls down to 30°C, fan stops.</p>	1,2,3	RW
P13.1.15	633	<p>Keypad ACK Timeout</p> <p>This function allows the user to change the timeout of the Keypad acknowledgement time. This is the communication performed between the control module and the keypad. This would be adjusted when using long communication cables between drive and a keypad to delay message timeouts. Example: Transfer delay between the frequency converter and the PC = 600 ms • The value of HMI Acknowledge Timeout is set to 1200 ms (2 x 600, sending delay + receiving delay) The corresponding setting shall be entered in the [Misc]-part of the file. • It must also be considered that intervals shorter than the HMI Acknowledge Timeout time cannot be used in frequency converter drive monitoring.</p>	1,2,3	RW
P13.1.16	634	<p>Keypad Retry Number</p> <p>With this parameter you can set the number of times the drive will try to receive acknowledgement when it has not been received within the acknowledgement time (HMI Acknowledge Timeout) or if the received acknowledgement is faulty.</p>	1,2,3	RW

Code	Modbus ID	Parameter	Application	RO/RW
P13.1.17	626	<p>Startup Wizard</p> <p>The Startup Wizard facilitates commissioning the drive. If selected Enable, the Startup Wizard prompts operator for the language and application desired, RTC time clock and then advances through the start-up parameter list/Application Mini wizard in keypad. After completion it allows the user to go to the Main menu or default page and this parameter is set to Disabled. The Startup Wizard is always enabled for the initial power up of the VFD. By setting this parameter to Disable without going through the Startup Wizard it will disable it from being active on Start up. If user goes into Start Up Wizard after completion or defaults drive the Startup wizard will be Enabled.</p> <p>0 = Enabled 1 = Disabled</p>	1,2,3	RW
P13.1.18	2412	<p>Jog Softkey Hidden</p> <p>Use this parameter to hidd the jog function from the soft key buttons.</p> <p>0 = Disable 1 = Enable</p>	1,2,3	RW
P13.1.19	2413	<p>Reverse Softkey Hidden</p> <p>Use this parameter to hide the Reverse fuction from the soft key buttons.</p> <p>0 = Disable 1 = Enable</p>	1,2,3	RW
P13.1.20	2424	<p>Output Display Unit</p> <p>This parameter allows for selecting a desired unit and scaled output to be viewed in the monitor menu as user output and refernece display. Value is scaled based on the max value setting the min and max value.</p> <p>0 = % 1 = 1/min 2 = rpm 3 = ppm 4 = pps 5 = l/s 6 = l/min 7 = l/h 8 = kg/s 9 = kg/min 10 = kg/h 11 = m3/s 12 = m3/min 13 = m3/h 14 = m/s 15 = mbar 16 = bar 17 = Pa 18 = kPa 19 = mVs 20 = kW 21 = deg C 22 = GPM 23 = gal/s 24 = gal/min 25 = gal/h 26 = lb/s 27 = lb/min 28 = lb/h 29 = CFM 30 = ft3/s 31 = ft3/min 32 = ft3/h 33 = ft/s 34 = in wg 35 = ft wg 36 = PSI 37 = lb/in2 38 = HP 39 = deg F 40 = PA 41 = WC 42 = HG 43 = ft 44 = m 45 = Hz 46 = Strokes/min</p>	1,2,3	RW

Appendix A—Description of parameters

Code	Modbus ID	Parameter	Application	RO/RW
P13.1.21	2460	Output Display Unit Min Use this parameter to set the minimum scaled value when changing the display unit to a value other than the default Hz.	1,2,3	RW
P13.1.22	2425	Output Display Unit Max Use this parameter to set the maximum scaled value when changing the display unit to a value other than the default Hz.	1,2,3	RW
P13.2.1	640	Keypad Software Version Keypad firmware Version	1,2,3	RO
P13.2.2	642	Motor Control Software Version DSP/Motor Control Software Version	1,2,3	RO
P13.2.3	644	Application Software Version MCU/Application Software Version	1,2,3	RO
P13.2.4	1714	Software Bundle Version Software bundle version number, this encompasses the keypad software, Motor control software and application software.	1,2,3	RO
P13.3.1	646	Brake Chopper This parameter is used to provide a status to indicate if the unit has a brake chopper installed in it.	1,2,3	RW
P13.3.2	647	Brake Resistor Status The Hardware information - indication of the Brake Resistor status being connected or disconnect.	1,2,3	RO
P13.3.3	648	Serial Number Serial Number of the drive.	1,2,3	RO
P13.4.1	566	Real Time Clock This parameter provides the ability to see and adjust the time clock settings in the drive. Formatted in MM.DD.YY, HH:MM:SS.	1,2,3	RW
P13.4.2	582	Daylight Saving This parameter provides the ability to see and adjust the daylight saving time rule. 0 = Off 1 = EU 2 = US	1,2,3	RW
P13.4.3	601	Total MWh Count Energy Consumption MWH Meter (not resettable)	1,2,3	RO
P13.4.4	603	Total Power Day Count Total Time Power is on, Days count (not resettable)	1,2,3	RO
P13.4.5	606	Total Power Hr Count Total time Power is on, Hr Count (not resettable)	1,2,3	RO
P13.4.6	604	Trip MWh Count Energy Consumption MWH Meter(resettable)	1,2,3	RO
P13.4.7	635	Clear Trip MWh Count This parameter will reset the Trip MWh count.	1,2,3	RW
P13.4.8	636	Trip Power Day Count Total Time Power is On, Days count (resettable)	1,2,3	RO
P13.4.9	637	Trip Power Hr Count Total time Power is on, Hr Count (resettable)	1,2,3	RO
P13.4.10	639	Clear Trip Power Count Resets the Trip Power Counter	1,2,3	RW
M1.1	1	Output Frequency Instantaneous output frequency going to the motor in Hz.		RO

Code	Modbus ID	Parameter	Application	RO/RW
M1.2	24	Freq Reference Instantaneous frequency reference value in Hz.	1,2,3	RO
M1.3	2	Motor Speed Calculated motor speed in rpms based off the motor parameters entered and the V/Hz curve when running.	1,2,3	RO
M1.4	3	Motor Current Measured Instantaneous output motor current.	1,2,3	RO
M1.5	4	Motor Torque Calculated instantaneous Motor-Torque in Percentage of total Motor Torque.	1,2,3	RO
M1.6	5	Motor Power Calculated instantaneous motor power in Percentage of total Motor Power.	1,2,3	RO
M1.7	6	Motor Voltage Measured instantaneous output voltage in AC to the motor.	1,2,3	RO
M1.8	7	DC-link Voltage Measured Instantaneous DC link Voltage	1,2,3	RO
M1.9	8	Unit Temperature Measured instantaneous device temperature in °C.	1,2,3	RO
M1.10	9	Motor Temperature Calculated motor temperature value in Percentage. Value is based off motor name plate data and the drive status information take when power up and a calculation performed while motor is active.	1,2,3	RO
M1.11	28	Latest Fault Code Active Fault code value. See fault codes for description of the value shown here.	1,2,3	RO
M1.12	1686	Instant Motor Power Measured Instantaneous motor power, units in kW.	1,2,3	RO
M1.13	583	RTC Battery Status Real time clock battery status.	1,2,3	RO
M2.1	10	Analog Input 1 Analog input 1 measured value, units will depend on analog mode setting of voltage or current.	1,2,3	RO
M2.2	11	Analog Input 2 Analog input 2 measured value, units will depend on analog mode setting of voltage or current.	1,2,3	RO
M2.3	25	Analog Output 1 Analog Output 1 measured value supplied from the drive, units will depend on analog mode setting of voltage or current.	1,2,3	RO
M2.4	575	Analog Output 2 Analog Output 2 measured value supplied from the drive, units will depend on analog mode setting of voltage or current.	1,2,3	RO
M2.5	12	DI1, DI2, DI3 Digital Input status for digital input 1, 2 and 3. IO Terminals 20, 21, 22.	1,2,3	RO
M2.6	13	DI4, DI5, DI6 Digital Input status for digital input 4, 5 and 6. IO Terminals 23, 7, 8.	1,2,3	RO
M2.7	576	DI7, DI8 Digital Input status for digital input 7 and 8. IO Terminals 9 and 10.	1,2,3	RO
M2.8	14	DO1,Virtual RO1,Virtual RO2 Digital Output status and Firmware Virtual Relay status. The Virtual RO1 and Virtual RO2 status are of internal relays in the control board not for external use, allows for turning on functions internal to the drive without the use of hardwire connections.	1,2,3	RO

Appendix A—Description of parameters

Code	Modbus ID	Parameter	Application	RO/RW
M2.9	557	R01, R02, R03 Relay output status for R01, R02 and R03. IO Terminals 27 through 34.	1,2,3	RO
M3.1	27	PT100 Temperture Maximum PT100 thermistor temperature value in °C.	1,2,3	RO
M4.1	2120	Energy Savings Displays the Energy savings of the drive comparted to an across the line starter based off the defined motor name plate values.	1,2,3	RO
M5.1	2209	Control Board DIDO Status Control Board DIDO Status provides the status of inputs and outputs on the control board. It is looking at DIN1 - Terminal 20, DIN2 - Terminal 21, DIN3 - Terminal 22, DIN4 - Terminal 23, DIN5 - Terminal 7, DIN6 - Terminal 8, DIN7 - Terminal 9, DIN8 - Terminal 10, DO1 - Terminal 14, R01 - Terminal 28-29, R02 - Terminal 32-34, R03 - Terminal 27 and 31. Along with the onboard I/O being monitored it also provides status info if there are boards in the A or B expander Board slots. Bit 0 = DIN1 Status Bit 1 = DIN2 Status Bit 2 = DIN3 Status Bit 3 = DIN4 Status Bit 4 = DIN5 Status Bit 5 = DIN6 Status Bit 6 = DIN7 Status Bit 7 = DIN8 Status Bit 8 = DO1 Status Bit 9 = R01 Status Bit 10 = R02 Status Bit 11 = R03 Status Bit 12 = Slot A with Board Bit 13 = Slot B with Board Bit 14 -15 = Not used	1,2,3	RO
M5.2	2210	SlotA DIDO Status SlotA DIDO Status will give the input and output status of a board inserted in the A expander board slot. Depending on the board inserted different bits will become active if the I/O is enabled. Bit 0 = IO1_DIN1 Status Bit 1 = IO1_DIN2 Status Bit 2 = IO1_DIN3 Status Bit 3 = IO1_DO1 Status Bit 4 = IO1_DO2 Status Bit 5 = IO1_DO3 Status Bite 6 = IO3_R01 Status Bit 7 = IO3_R02 Status Bit 8 = IO3_R03 Status Bit 9 = IO5_AC1 Status Bit 10 = IO5_AC2 Status Bit 11 = IO5_AC3 Status Bit 12 = IO5_AC4 Status Bit 13 = IO5_AC5 Status Bit 14 = IO5_AC6 Status Bit 15 = Not Used	1,2,3	RO

Code	Modbus ID	Parameter	Application	RO/RW
M5.3	2211	SlotB DIDO Status SlotB DIDO Status will give the input and output status of a board inserted in the B expander board slot. Depending on the board inserted different bits will become active if the I/O is enabled. Bit 0 = IO1_DIN1 Status Bit 1 = IO1_DIN2 Status Bit 2 = IO1_DIN3 Status Bit 3 = IO1_DO1 Status Bit 4 = IO1_DO2 Status Bit 5 = IO1_DO3 Status Bit 6 = IO3_RO1 Status Bit 7 = IO3_RO2 Status Bit 8 = IO3_RO3 Status Bit 9 = IO5_AC1 Status Bit 10 = IO5_AC2 Status Bit 11 = IO5_AC3 Status Bit 12 = IO5_AC4 Status Bit 13 = IO5_AC5 Status Bit 14 = IO5_AC6 Status Bit 15 = Not Used	1,2,3	RO
M5.4	29	Application Status Word Application Status word will provide additional status indication of the health of the drive. Bit 0 = MC Ready Bit 1 = MC_Run Bit 2 = MC_Fault Bit 3 = FB_Ref_Active Bit 4 = MC_Stopping Bit 5 = MC_Reverse Bit 6 = MC_Warning/AR-Fault Bit 7 = MC_ZeroSpeed Bit 8 = I/O Control Indicate Bit 9 = Panel Control Indicator Bit 10 = Panel Fieldbus Indicator Bit 11 = MC_DC_Brake Bit 12 = RunEnable Bit 13 Motor Regulator Status not Zero Bit 14 = Ext Brake Control Bit 15 = Bypass Mode	1,2,3	RO
M5.5	2414	Standard Status Word Standard Status Word is defined based of the parameter setting in the Fieldbus Process Data Output group, define the first 8 bits of this status word. The options for these bits are based off the standard Relay functions. Bit 0 = parameter Para ID 2415 (default = Ready) Bit 1 = parameter Para ID 2416 (default = Run) Bit 2 = parameter Para ID 2417 (default = Fault) Bit 3 = parameter Para ID 2418 (default = Fault Invert) Bit 4 = parameter Para ID 2419 (default = Warning) Bit 5 = parameter Para ID 2420 (default = Reversed) Bit 6 = parameter Para ID 2421 (default = At Speed) Bit 7 = parameter Para ID 2422 (default = Zero Frequency) Bit 8 - 15 = Not Used	1,2,3	RO
M6.1	16	PID1 Set Point PI(D) Controller 1 setpoint reference value, units will vary based on PI(D) Controller 1 units setting.	2,3	RO
M6.2	18	PID1 Feedback PI(D) Controller 1 actual value feedback, units will vary based on the PI(D) Controller 1 unit setting.	2,3	RO
M6.3	20	PID1 Error Value PI(D) Controller 1 Error or difference from between the reference and feedback, units will vary based on the PI(D) Controller 1 unit setting.	2,3	RO
M6.4	22	PID1 Output PI(D) Controller 1 output value in percentage.	2,3	RO
M6.5	23	PID1 Status PI(D) Controller 1 status indication, indicates if drive is stopped, running in PID mode, or in PID sleep mode.	2,3	RO

Appendix A—Description of parameters

Code	Modbus ID	Parameter	Application	RO/RW
M6.6	32	PID2 Set Point PI(D) Controller 2 setpoint reference value, units will vary based on PI(D) Controller 2 units setting.	2,3	RO
M6.7	34	PID2 Feedback PI(D) Controller 2 actual value feedback, units will vary based on the PI(D) Controller 2 unit setting.	2,3	RO
M6.8	36	PID2 Error Value PI(D) Controller 2 Error or difference from between the reference and feedback, units will vary based on the PI(D) Controller 2 unit setting.	2,3	RO
M6.9	38	PID2 Output PI(D) Controller output value in percentage.	2,3	RO
M6.10	39	PID2 Status PI(D) Controller 2 status indication, indicates if drive is stopped, running in PID mode, or in PID sleep mode.	2,3	RO
M7.1	558	TC1, TC2, TC3 Timer channel status of channel 1, 2 and 3. Timer channels are used within the RTC parameter group settings.	2,3	RO
M7.2	559	Interval 1 Time interval 1 status. See the RTC parameters for checking Interval 1 setup, when setting is met the status will go indicated on and when not met it will be off.	2,3	RO
M7.3	560	Interval 2 Time interval 2 status. See the RTC parameters for checking Interval 2 setup, when setting is met the status will go indicated on and when not met it will be off.	2,3	RO
M7.4	561	Interval 3 Time interval 3 status. See the RTC parameters for checking Interval 3 setup, when setting is met the status will go indicated on and when not met it will be off.	2,3	RO
M7.5	562	Interval 4 Time interval 4 status. See the RTC parameters for checking Interval 4 setup, when setting is met the status will go indicated on and when not met it will be off.	2,3	RO
M7.6	563	Interval 5 Time interval 5 status. See the RTC parameters for checking Interval 5 setup, when setting is met the status will go indicated on and when not met it will be off.	2,3	RO
M7.7	569	Timer 1 Timer 1 value in seconds, value counts up to set timer value. See the RTC parameter group for defined Timer value.	2,3	RO
M7.8	571	Timer 2 Timer 2 value in seconds, value counts up to set timer value. See the RTC parameter group for defined Timer value.	2,3	RO

Code	Modbus ID	Parameter	Application	RO/RW
M7.9	573	Timer 3 Timer 3 value in seconds, value counts up to set timer value. See the RTC parameter group for defined Timer value.	2,3	RO
M8.1	2445	Output User defined output value that can be seen in a specific desired unit and scale factor based on the output frequency. This value will be displayed in the format selected by parameter Para ID 2426 with a scale value from parameter Para ID 2462 and 2427.	1,2,3	RO
M8.2	2447	Reference User defined reference value that can be seen in the desired unit and scale factor based on the frequency reference. This value will be displayed in the format selected by parameter Para ID 2426 with a scale value from parameter Para ID 2462 and 2427.	1,2,3	RO
M9.1	601	Total MWh Count Energy Consumption MWH Meter (not resettable)	1,2,3	RO
M9.2	603	Total Power Day Count Total Time Power is on, Days count (not resettable)	1,2,3	RO
M9.3	606	Total Power Hr Count Total time Power is on, Hr Count (not resettable)	1,2,3	RO
M9.4	604	Trip MWh Count Energy Consumption MWH Meter(resettable)	1,2,3	RO
M9.5	636	Trip Power Day Count Total Time Power is On, Days count (resettable)	1,2,3	RO
M9.6	637	Trip Power Hr Count Total time Power is on, Hr Count (resettable)	1,2,3	RO
M10.1	30	Multi-Monitoring Displays any 3 monitoring values in a single screen. The values are selectable via the keypad menu. by going to the Multi-Monitor page and seeing 3 lines of Monitoring values, Up and Down keys can be used to select the row and then hitting the left arrow key will allow for editing the value then by going up and down.	1,2,3	RW

Appendix B— Fault Log

Under this menu, you can find Active faults, History faults and Fault codes.

Table 215. Active faults

Menu	Function	Note
Active Faults	When a fault/faults appear(s), the display with the name and fault time of the fault will be pop. Press DETAIL to see the fault data. The Active Faults submenu shows the list of faults. Select the fault and push DETAIL to see the fault data.	The fault remains active until it is cleared with the Reset button (push for 2s) or with a reset signal from the I/O terminal or Fieldbus. The memory of active faults can store the maximum of 10 faults in the order of appearance.

Table 216. History faults

Menu	Function	Note
History Faults	10 latest faults are stored in the Fault history, Select the fault and push DETAIL to see the fault data.	The history fault will be stored until it is cleared with the OK button (push for 5s). The memory of active faults can store the maximum of 10 faults in the order of appearance.

Fault codes and descriptions

Configurable 1 = The fault type of this fault is configurable, fault type can be configured as
0 = No Action; 1 = Warning; 2 = Fault; 3= Fault, Coast

Fault code	Fault Name	Fault Type	Default	Possible Cause	Remedy	Realization
1	Over Current	Fault		AC drive has detected too high a current (>4*I _H) in the motor cable: <ul style="list-style-type: none"> Sudden heavy load increase Short circuit in motor cables Unsuitable motor 	<ul style="list-style-type: none"> Check loading Check motor Check cables and connections Make identification run Check ramp times 	DSP
2	Over Voltage	Fault		The DC-link voltage has exceeded the limits defined: <ul style="list-style-type: none"> Too short a deceleration time Brake chopper is disabled High overvoltage spikes in supply Start/Stop sequence too fast 	<ul style="list-style-type: none"> Make deceleration time longer Use brake chopper or brake resistor (available as options) Activate overvoltage controller Check input voltage 	DSP
3	Earth Fault	Configurable	Fault	Current measurement has detected that the sum of motor phase current is not zero: <ul style="list-style-type: none"> Insulation failure in cables or motor 	Check motor cables and motor	DSP
5	Charging Switch	Fault		<ul style="list-style-type: none"> The charging switch is open, when the START command has been given: Faulty operation Component failure 	<ul style="list-style-type: none"> Reset the fault and restart Should the fault re-occur, contact the distributor near to you 	DSP
7	Saturation Trip	Fault		<ul style="list-style-type: none"> Short circuit in motor cables IGBT module is damaged 	<ul style="list-style-type: none"> Check cables and connections Reset the fault and restart Verify that EMC screw is installed Should the fault re-occur, contact the distributor near to you 	DSP
9	Under Voltage	Configurable	Fault	DC link voltage is under the voltage limits defined: <ul style="list-style-type: none"> Most probable cause: Too low a supply voltage AC drive internal fault Defect input fuse External charge switch not closed Note: This fault is activated only if the drive is in Run state.	In case of temporary supply voltage break reset the fault and restart the AC drive Check the supply voltage. If it is adequate, an internal failure has occurred. Contact the distributor near you	DSP
10	Input Phase Superv	Configurable	Fault	Input line phase is missing	Check supply voltage, fuses and cable	DSP
11	Output Phase Superv	Configurable	Fault	Current measurement has detected that there is no current in one motor phase	Check motor cable and motor	DSP

Fault code	Fault Name	Fault Type	Default	Possible Cause	Remedy	Realization
12	Brake Chopper Superv Fault			<ul style="list-style-type: none"> No brake resistor installed Brake resistor is broken Brake chopper failure 	Check brake resistor and cabling. If these are OK, the chopper is faulty. Contact the distributor near you	DSP
13	Drive UnderTemp	Configurable	Warning	<ul style="list-style-type: none"> Too low temperature measured in power Unit's heat sink or board. Heat sink temperature is under -10°C 		DSP
14	Drive OverTemp	Fault		<ul style="list-style-type: none"> Too high temperature measured in power Unit's heat sink or board. Heat sink temperature is over 90°C 	<ul style="list-style-type: none"> Check the correct amount and flow of cooling air Check the heat sink for dust Check the ambient temperature Make sure that the switching frequency is not too high in relation to ambient temperature and motor load 	DSP
15	Motor Stalled	Configurable	No Action	Motor is stalled	Check motor and load	DSP
16	Motor Over Temp	Configurable	No Action	Motor is too hot, based on either the drive's estimate or on temperature feedback	Decrease motor load. If no motor overload exists, check the temperature model parameters	DSP
17	Motor Under Load	Configurable	No Action	Condition defined by parameter P6.1.11-P6.1.13 have been valid longer than the time defined by P6.1.14	Check load	DSP
18	IP Address Conflict	Configurable	Warning	IP setting issue.	Check settings for IP address, verify no duplicates are on the network.	MCU
19	Power Board EEPROM Fault	Fault		Power board eeprom fault, memory lost in eeprom.	Cycle power to drive. Try updating software, if issue continues contact Distributor near you.	MCU
20	FRAM Fault	Fault		FRAM data error in FRAM memory.	Cycle power to drive. Try updating software, if issue continues contact a Distributor near you.	MCU
21	S-Flash Fault	Warning		Serial flash error, serial flash memory failed.	Cycle power to drive. Try updating software, if issue continues contact a Distributor near you.	MCU
25	MCU Watchdog Fault	Fault		Watchdog register overflows in MCU	Cycle power to drive. Try updating software, if issue continues contact a Distributor near you.	MCU
26	Start-up Prevent	Fault		The time when Interlock signal activates is over setting time.	Stop drive and resend start command.	MCU
29	Thermistor Fault	Configurable	Fault	Option board or control board thermistor resistor lager than 4.7K	Thermistor open or short, over temperature	MCU
32	Fan Cooling	Fault		Fan is damaged or stalled.	Check fan and fan connected wires, verify 24Vdc is supplied to fan.	DSP
36	Compatibility Fault	Fault		The control board isn't match with the power board.	Cycle power to drive. Try updating software, if issue continues contact a Distributor near you.	MCU
37	Device Change	Warning		Power board or option card change.	Alarm will reset	MCU
38	Device Added	Warning		Power board or option board added.	<ul style="list-style-type: none"> Device is ready for use Old parameter settings will be used 	MCU
39	Device Removed	Fault		Optional board removed from slot, or power board removed from control board.	Device no longer available in drive.	MCU
40	Device Unknown	Fault		Unknown device connected (power board/option board)	<ul style="list-style-type: none"> Check eeprom connection. Check board connection on slot A/B Power cycle to drive. 	MCU
41	IGBT Over Temp	Fault		IGBT temperature is too high.	<ul style="list-style-type: none"> Check output loading Check motor size Decrease switching frequency 	DSP
50	AI < 4mA (4to20mA)	Configurable	No Action	Loss in analog input signal, dropped below 4mA.	Verify analog input current reference value on either AI1 or AI2, check cabling.	MCU
51	External Fault	Configurable	Fault	Digital input is activated for external fault input.	Check digital input settings and verify input level, could be an external device causing fault.	MCU

Appendix B— Fault Log

Fault code	Fault Name	Fault Type	Default	Possible Cause	Remedy	Realization
52	Keypad Comm Fault	Configurable	Fault	The connection between the control keypad and frequency converter is broken, and The local reference is keypad reference or the local control place is keypad, and The keypad communication fault protection is not "NO action"	Check keypad connection and possible keypad cable.	MCU
54	Option Card Fault	Configurable	Fault	Defective option card or option card slot	<ul style="list-style-type: none"> • Check right option card and option card slot connections. • Check Board Status on Keypad for exact cause of fault. • Contact distributor nearest you. 	MCU
55	Real-time Clock Fault	Configurable	Warning	<ul style="list-style-type: none"> • Communication between MCU and RTC chip isn't normal • The power of RTC chip isn't normal • The real time isn't normal 	Check the RTC chip, power cycle to drive. If issue continues contact distributor near you.	MCU
56	PT100 Fault	Configurable	Fault	Temperature is beyond the limit of sensing capacity of PT100	Pt100 short, open or over temperature, check PT100 temperature probe.	MCU
57	Motor ID fault	Fault		The Motor parameters Identification running was not completed successfully	<ul style="list-style-type: none"> • Check motor size • Verify the input and output wiring is connected properly. 	DSP
58	Current Measure Fault	Fault		Current measurement is out of range	Restart the drive again. Should the fault re-occur, contact the distributor near to you	DSP
59	Power Wiring Error	Fault		Power wiring connected to output of drive.	Verify power input wiring is connected to L1, L2 and L3 terminals and they are properly torqued.	DSP
60	Control Board Over Temp	Fault		Control board is over +85 degrees or under -30 degrees	<ul style="list-style-type: none"> • Check NTC resistor • Check control board temperature 	MCU
61	Internal Control Supply Fault			+24V port voltage is over 27V or under 17V	Check voltage range of +24V on terminals 12 to 13. If voltage is out of range contact distributor near you.	MCU
62	Speed Search Fault	Fault		Speed searching failed when performing flying start.	Check motor parameters' setting and motor connections.	DSP
64	Replace Battery	Configurable	Warning	RTC Battery voltage is too low.	Check the RTC battery voltage, contact distributor near you for replacement battery.	MCU
65	Replace Fan	Configurable	Warning	Fan life is less than 2 months	Check the fan, clean out any contamination, contact distributor near you for replacement fan.	MCU
66	Safety Torque Off	Fault		STO Triggered, STO input is open.	Reset STO Trigger and verify wiring. Reset fault after input is enabled.	DSP
67	Current Limit Control	Warning		The output current has reached the current limit value	<ul style="list-style-type: none"> • Check the load • Set the acceleration time longer 	DSP
68	Over Voltage Control	Warning		The DC link voltage has reached its voltage limit value	<ul style="list-style-type: none"> • Check the input voltage • Set the acceleration/deceleration time longer 	DSP
69	System Fault	Fault		Thermistor spi communication error.	Check thermistor chip.	MCU
70	System Fault	Fault		MCU send wrong parameters to DSP.	Restart the drive again. Should the fault re-occur, contact the distributor near to you.	DSP
80	Fieldbus Fault	Configurable	Fault	Loss of communication with BACnet IP, and the fieldbus reference is the remote reference OR the fieldbus control place is the remote control place.	Check RS485 communication wiring. Verify drive parameter are set correctly. Check master programming to verify proper addressing.	MCU

Fault code	Fault Name	Fault Type	Default	Possible Cause	Remedy	Realization
81	Fieldbus Fault	Configurable	Fault	Loss of communication with SA Bus, and the fieldbus reference is the remote reference OR the fieldbus control place is the remote control place.	Check RS485 communication wiring. Verify drive parameter are set correctly. Check master programming to verify proper addressing.	MCU
82	Bypass Overload	Fault		Over load when motor is in bypass mode	Check motor connection situation	MCU
83	Fieldbus Fault	Configurable	Fault	Loss of communication with Modbus RTU, and the fieldbus reference is the remote reference OR the fieldbus control place is the remote control place.	Check RS485 communication wiring. Verify drive parameter are set correctly. Check master programming to verify proper addressing.	MCU
84	Fieldbus Fault	Configurable	Fault	Loss of communication with Modbus TCP, and the fieldbus reference is the remote reference OR the fieldbus control place is the remote control place.	Check Ethernet communication wiring. Verify drive parameter are set correctly. Check master programming to verify proper addressing.	MCU
85	Fieldbus Fault	Configurable	Fault	Loss of communication with BACnet MSTP, and the fieldbus reference is the remote reference OR The fieldbus control place is the remote control place and The fault protection is not "NO action"	Check RS485 communication wiring. Verify drive parameter are set correctly. Check BACnet MSTP master configuration programming to verify proper addressing.	MCU
86	Fieldbus Fault	Configurable	Fault	Loss of communication with Ethernet IP, and The fieldbus reference is the remote reference OR The fieldbus control place is the remote control place and The fault protection is not "NO action"	Check Ethernet communication wiring. Verify drive parameter are set correctly. Check EIP master configuration programming to verify proper addressing.	MCU
87	Fieldbus Fault	Configurable	Fault	Loss of communication with Profibus/Canopen/Devicenet master on Slot A, and the fieldbus reference is the remote reference OR The fieldbus control place is the remote control place and The fault protection is not "NO action"	Check Profibus/Canopen/Devicenet communication wiring. Verify drive parameter are set correctly. Check Profibus/Canopen/Devicenet master configuration programming to verify proper addressing.	MCU
88	Fieldbus Fault	Configurable	Fault	Loss of communication with Profibus/Canopen/Devicenet master on Slot B, and the fieldbus reference is the remote reference OR The fieldbus control place is the remote control place, and The fault protection is not "NO action"	Check Profibus/Canopen/Devicenet communication wiring. Verify drive parameter are set correctly. Check Profibus/Canopen/Devicenet master configuration programming to verify proper addressing.	MCU
89	Under Voltage Stop	Fault		The DC link voltage has reached the Drive under voltage stop limit value.	Check the input voltage.	DSP
90	Drive Under Temp	Warning/Fault		<ul style="list-style-type: none"> Cold weather mode is not enabled, and unit temperature is less than -10 degree. Cold weather mode is enabled and Under Temp Fault Override is not set, unit temperature is less than -30 degree. Cold weather mode is enabled and under Temp Fault Override is not set, unit temperature is -20~ -30 degree. The temp <-20 degree when cold weather start time out. 	If unit temp -20 ~ -10 degree, start motor in cold weather mode. If unit temp <-20 degree, Warm up unit above -20deg C for proper operation using cold weather mode. If still < -20 degree when cold weather mode time out, try higher output voltage in cold weather mode.	DSP

Appendix B— Fault Log

Fault code	Fault Name	Fault Type	Default	Possible Cause	Remedy	Realization
91	Option Card Fault	Configurable	Fault	External supply on the DeviceNet communication connector is not present.	Check voltage and wiring of power supply of the DeviceNet communication.	MCU
92	External Fault 2	Configurable	Fault	Digital input is activated for external fault input.	Check digital input settings and verify input level, could be an external device causing fault.	MCU
93	External Fault 3	Configurable	Fault	Digital input is activated for external fault input.	Check digital input settings and verify input level, could be an external device causing fault.	MCU
103	Drive OverTemp Warning	Warning		Drive is 10 degrees from the trip point of 90 deg C.	Check the drive degree	DSP
104	Compatibility Fault	Warning		DSP firmware is not compatible with MCB firmware	Check the DSP firmware revision	MCU
105	Compatibility Fault	Warning		Keypad firmware is not compatible with MCB firmware	Check the keypad firmware revision	MCU
106	Compatibility Fault	Warning		IO1 card firmware is not compatible with MCB firmware	Check the IO1 card firmware revision	MCU
107	Compatibility Fault	Warning		IO2 card firmware is not compatible with MCB firmware	Check the IO2 card firmware revision	MCU
108	Compatibility Fault	Warning		IO3 card firmware is not compatible with MCB firmware	Check the IO3 card firmware revision	MCU
109	Compatibility Fault	Warning		IO4 card firmware is not compatible with MCB firmware	Check the IO4 card firmware revision	MCU
110	Compatibility Fault	Warning		IO5 card firmware is not compatible with MCB firmware	Check the IO5 card firmware revision	MCU
111	Compatibility Fault	Warning		Profibus card firmware is not compatible with MCB firmware	Check the Profibus card firmware revision	MCU

Appendix C—Recommended secure hardening guidelines

Introduction

This section “secure configuration” or “hardening” guidelines provide information to the users to securely deploy and maintain this product to adequately minimize the cybersecurity risks to their system.

Johnson Controls is committed to minimizing the Cybersecurity risk in its products and deploys cybersecurity best practices and latest cybersecurity technologies in its products and solutions; making them more secure, reliable and competitive for our customers.

Secure configuration guidelines

Category	Description
Asset identification and Inventory	<p>Keeping track of all the devices in the system is a pre-requisite for effective management of Cybersecurity of a system. Ensure you maintain an inventory of all the components in your system in a manner in which you uniquely identify each component. To facilitate this VFD supports the following identifying information - manufacturer, type, serial number, f/w version number, and location.</p> <p>Customers/users can read following information from product label</p> <ul style="list-style-type: none"> • Model Number • Serial Number • Device Name <p>Information specific to communication protocols is available form parameter menu as below</p> <ul style="list-style-type: none"> • IP Address Mode • Active IP Address • MAC Address <p>See application manual for these parameter locations.</p>
Restrict Physical access	<p>Industrial Control Protocols don't offer cryptographic protections at protocol level leaving them exposed to Cybersecurity risk. Physical security is an important layer of defense in such cases. VFD is designed with the consideration that it would be deployed and operated in a physically secure location.</p> <ul style="list-style-type: none"> • Access to cabinets and/or enclosures containing VFD and the associated system should be restricted, monitored and logged at all times. • Physical access to the communication lines should be restricted to prevent any attempts of wiretapping, sabotage. It's a best practice to use metal conduits for the communication lines running between one cabinet to another cabinet. • Attacker with unauthorized physical access to the device could cause serious disruption of the device functionality. A combination of physical access controls to the location should be used, such as locks, card readers, and/or guards etc. • VFD supports the following physical access ports, <ul style="list-style-type: none"> • RJ45 connector for removable keypad as well as Modbus RTU communications • RJ45 for EtherNet IP/Modbus TCP communications • Terminal block for Modbus RTU and other Digital IOs <p>Access to above physical ports need to be restricted.</p>

Appendix C—Recommended Secure Hardening Guidelines

Category	Description
Restrict Logical access to Drive	<p>It is extremely important to securely configure the logical access mechanisms provided in VFD to safeguard the device from unauthorized access. VFD provides various types of administrative, operational, configuration privilege levels. The available access control mechanisms should be used properly to ensure that access to the system is restricted to legitimate users only. And, such users are restricted to only the privilege levels necessary to complete their job roles/functions.</p> <p>Below are best practices to be followed to ensure adequate cybersecurity of the setup/system</p> <ul style="list-style-type: none">• Default credentials are changed upon first login. VFD should not be commissioned for production with Default credentials, it's a serious Cybersecurity flaw as the default credentials are published in the manuals. Restrict administrative privileges - Threat actors are increasingly focused on gaining control of legitimate credentials, especially those associated with highly privileged accounts. Limit privileges to only those needed for a user's duties. Make sure that the password used in the device is only available to authorized users like Configuring Engineers and not shared among all operational users.• Perform periodic account maintenance to make sure that password is changed whenever there is personnel change.• Change passwords and other system access credentials as appropriate• VFD is provided with data/access protection mechanism on keypad, follow below steps to utilize it <p>VFD provides four levels of data protection for users to ensure the security:</p> <ol style="list-style-type: none">1. Lock parameters on keypad. User can lock the parameters through DI or disable change, in which way all the parameters cannot be edited.2. Lock parameters while motor running. Motor control parameters can only be modified when motor is in stop mode. In which way to enhance the motor security. The parameters are listed in the application manual.3. Through Power Xpert <i>in</i>Control tool, facility to hide parameters on keypad is available. User can hide the parameters he/she thinks are significant for himself/herself. Such as IP address and so on.4. Password on keypad.<ul style="list-style-type: none">• 0000 means no password, which is the default.• Password range is 0001 – 9999.• With password, user can monitor parameters value but need enter password if he/she wants to edit parameters.• User needs to re-enter the password if there is no key operation in 1 min after enter the password.• User needs to enter the old password if he/she wants to change to a new one.
Restrict Network Access	<p>VFD provides network access to facilitate communication with other devices in the systems and configuration. But this capability could open up a big security hole if it's not configured securely.</p> <p>Segmentation of networks into logical enclaves and restrict the communication to host-to-host paths. This helps protect sensitive information and critical services and limits damage from network perimeter breaches. At a minimum, a utility Industrial Control Systems network should be segmented into a three-tiered architecture (as recommended by NIST SP800-82[R3]) for better security control.</p> <p>Deploy adequate network protection devices like Firewalls, Intrusion Detection / Protection devices,</p> <p>Below are the protocols and their port details available on VFD. Use below information for configuring the firewalls.</p> <p>VFD provides below communication protocols –</p> <ul style="list-style-type: none">• EtherNet IP protocols on RJ45 connector – enabled by default on port 44818 and 2222• Modbus TCP protocol on RJ45 connector – enabled by default on port 502• Modbus RTU on RS485 physical layer – enabled by default• BACnet MS/TP on RS485 physical layer – disabled by default, when this is enabled, Modbus RTU is disabled. <p>All the protocols have dedicated menu structure, and details are described in User's Manual for how to activate or configure them.</p> <ul style="list-style-type: none">• Detailed information about various Network level protection strategies in Cybersecurity Considerations for Electrical Distribution Systems [R1].

Category	Description
Logging and Event Management	<p>Best Practices</p> <ul style="list-style-type: none"> • VFD provides parameters change log and fault log functions for user, to help diagnose the drive <p>1. Parameters change log:</p> <ul style="list-style-type: none"> • VFD will log the parameter information in FRAM when the parameter changes. The max number of 66 items can be logged. New log will rewrite the old one. User cannot clear this fault information. <p>2. Fault log:</p> <ul style="list-style-type: none"> • VFD will log the drive information in FRAM when fault occurs. The max number of 10 items can be logged. New log will rewrite the old one. User can clear the history fault by pressing OK key more than 5 Sec. • VFD will log the fault information in FRAM when fault occurs. The max number of 50 items can be logged. New log will rewrite the old one. User cannot clear this fault information.
Secure Maintenance	<p>Best Practices</p> <p>Apply Firmware updates and patches regularly</p> <p>Due to rapidly increasing Cyber Threats in Industrial Control Systems, Johnson Controls implements a comprehensive patch and update process for its products. Users are encouraged to maintain a consistent process to promptly monitor for fresh firmware updates and apply the update whenever required.</p>

Appendix C—Recommended Secure Hardening Guidelines



© 2018 Johnson Controls
All Rights Reserved
Printed in USA
Publication No. LIT-12012999 / Z20874
June 2018